

# LM5575/LM5575Q SIMPLE SWITCHER® 75V, 1.5A Step-Down Switching Regulator

Check for Samples: [LM5575](#)

## FEATURES

- **LM5575Q is an Automotive Grade Product that is AEC-Q100 Grade 1 Qualified (–40°C to +125°C Operating Junction Temperature)**
- **Integrated 75V, 330mΩ N-channel MOSFET**
- **Ultra-wide Input Voltage Range from 6V to 75V**
- **Adjustable Output Voltage as Low as 1.225V**
- **1.5% Feedback Reference Accuracy**
- **Operating Frequency Adjustable Between 50kHz and 500kHz with Single Resistor**
- **Master or Slave Frequency Synchronization**
- **Adjustable Soft-Start**
- **Emulated Current Mode Control Architecture**
- **Wide Bandwidth Error Amplifier**
- **Built-in Protection**
- **Automotive Grade Product Datasheet that is AEC-Q100 Grade 0 Qualified is Available Upon Request.**
  - (–40°C to +150°C Operating Junction Temperature)

## APPLICATIONS

- Automotive
- Industrial

## Simplified Application Schematic

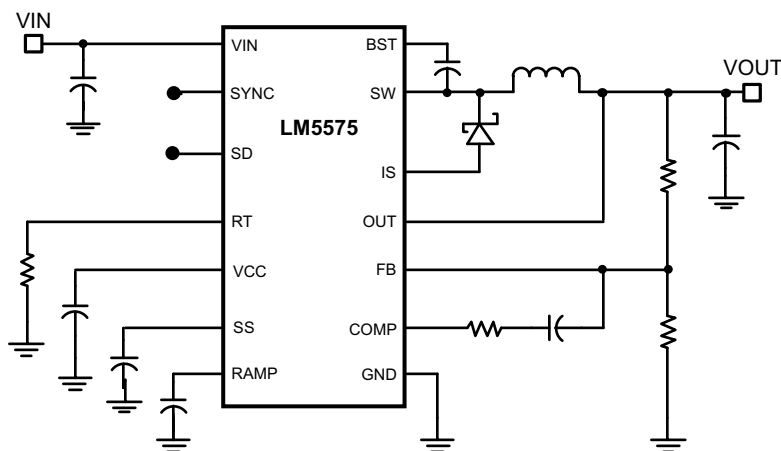

## DESCRIPTION

The LM5575 is an easy to use SIMPLE SWITCHER® buck regulator which allows design engineers to design and optimize a robust power supply using a minimum set of components. Operating with an input voltage range of 6 - 75V, the LM5575 delivers 1.5A of continuous output current with an integrated 330mΩ N-Channel MOSFET. The regulator utilizes an Emulated Current Mode architecture which provides inherent line regulation, tight load transient response, and ease of loop compensation without the usual limitation of low-duty cycles associated with current mode regulators. The operating frequency is adjustable from 50kHz to 500kHz to allow optimization of size and efficiency. To reduce EMI, a frequency synchronization pin allows multiple IC's from the LM(2)557x family to self-synchronize or to synchronize to an external clock. The LM5575 ensures robustness with cycle-by-cycle current limit, short-circuit protection, thermal shut-down, and remote shut-down. The device is available in a power enhanced HTSSOP-16 package featuring an exposed die attach pad for thermal dissipation. The LM5575 is supported by the full suite of WEBENCH® On-Line design tools.

## PACKAGE

- **HTSSOP-16EP (Exposed Pad)**



Please be aware that an important notice concerning availability, standard warranty, and use in critical applications of Texas Instruments semiconductor products and disclaimers thereto appears at the end of this data sheet.

WEBENCH is a registered trademark of Texas Instruments.  
All other trademarks are the property of their respective owners.

## Connection Diagram

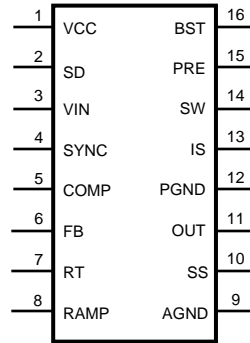

**Figure 1. Top View  
16-Lead HTSSOP**

### PIN DESCRIPTIONS

Pin(s)	Name	Description	Application Information
1	VCC	Output of the bias regulator	Vcc tracks Vin up to 9V. Beyond 9V, Vcc is regulated to 7 Volts. A 0.1uF to 1uF ceramic decoupling capacitor is required. An external voltage (7.5V – 14V) can be applied to this pin to reduce internal power dissipation.
2	SD	Shutdown or UVLO input	If the SD pin voltage is below 0.7V the regulator will be in a low power state. If the SD pin voltage is between 0.7V and 1.225V the regulator will be in standby mode. If the SD pin voltage is above 1.225V the regulator will be operational. An external voltage divider can be used to set a line undervoltage shutdown threshold. If the SD pin is left open circuit, a 5uA pull-up current source configures the regulator fully operational.
3	Vin	Input supply voltage	Nominal operating range: 6V to 75V
4	SYNC	Oscillator synchronization input or output	The internal oscillator can be synchronized to an external clock with an external pull-down device. Multiple LM5575 devices can be synchronized together by connection of their SYNC pins.
5	COMP	Output of the internal error amplifier	The loop compensation network should be connected between this pin and the FB pin.
6	FB	Feedback signal from the regulated output	This pin is connected to the inverting input of the internal error amplifier. The regulation threshold is 1.225V.
7	RT	Internal oscillator frequency set input	The internal oscillator is set with a single resistor, connected between this pin and the AGND pin.
8	RAMP	Ramp control signal	An external capacitor connected between this pin and the AGND pin sets the ramp slope used for current mode control. Recommended capacitor range 50pF to 2000pF.
9	AGND	Analog ground	Internal reference for the regulator control functions
10	SS	Soft-start	An external capacitor and an internal 10uA current source set the time constant for the rise of the error amp reference. The SS pin is held low during standby, Vcc UVLO and thermal shutdown.
11	OUT	Output voltage connection	Connect directly to the regulated output voltage.
12	PGND	Power ground	Low side reference for the PRE switch and the IS sense resistor.
13	IS	Current sense	Current measurement connection for the re-circulating diode. An internal sense resistor and a sample/hold circuit sense the diode current near the conclusion of the off-time. This current measurement provides the DC level of the emulated current ramp.
14	SW	Switching node	The source terminal of the internal buck switch. The SW pin should be connected to the external Schottky diode and to the buck inductor.

**PIN DESCRIPTIONS (continued)**

Pin(s)	Name	Description	Application Information
15	PRE	Pre-charge assist for the bootstrap capacitor	This open drain output can be connected to SW pin to aid charging the bootstrap capacitor during very light load conditions or in applications where the output may be pre-charged before the LM5575 is enabled. An internal pre-charge MOSFET is turned on for 250ns each cycle just prior to the on-time interval of the buck switch.
16	BST	Boost input for bootstrap capacitor	An external capacitor is required between the BST and the SW pins. A 0.022 $\mu$ F ceramic capacitor is recommended. The capacitor is charged from V <sub>CC</sub> via an internal diode during the off-time of the buck switch.
NA	EP	Exposed Pad	Exposed metal pad on the underside of the device. It is recommended to connect this pad to the PWB ground plane, in order to aid in heat dissipation.



These devices have limited built-in ESD protection. The leads should be shorted together or the device placed in conductive foam during storage or handling to prevent electrostatic damage to the MOS gates.

**Absolute Maximum Ratings<sup>(1)(2)</sup>**

V <sub>IN</sub> to GND	76V
BST to GND	90V
PRE to GND	76V
SW to GND (Steady State)	-1.5V
BST to V <sub>CC</sub>	76V
SD, V <sub>CC</sub> to GND	14V
BST to SW	14V
OUT to GND	Limited to V <sub>in</sub>
SYNC, SS, FB, RAMP to GND	7V
ESD Rating <sup>(3)</sup>	Human Body Model 2kV
Storage Temperature Range	-65°C to +150°C

- (1) Absolute Maximum Ratings are limits beyond which damage to the device may occur. Operating Ratings are conditions under which operation of the device is intended to be functional. For ensured specifications and test conditions, see the [Electrical Characteristics](#).
- (2) If Military/Aerospace specified devices are required, please contact the Texas Instruments Sales Office/Distributors for availability and specifications.
- (3) The human body model is a 100pF capacitor discharged through a 1.5k $\Omega$  resistor into each pin.

**Operating Ratings<sup>(1)</sup>**

V <sub>IN</sub>	6V to 75V
Operation Junction Temperature	-40°C to +125°C

- (1) Absolute Maximum Ratings are limits beyond which damage to the device may occur. Operating Ratings are conditions under which operation of the device is intended to be functional. For ensured specifications and test conditions, see the [Electrical Characteristics](#).

## Electrical Characteristics

Specifications with standard typeface are for  $T_J = 25^\circ\text{C}$ , and those with **boldface** type apply over full **Operating Junction Temperature range**.  $V_{IN} = 48\text{V}$ ,  $R_T = 32.4\text{k}\Omega$  unless otherwise stated.<sup>(1)</sup>

Symbol	Parameter	Conditions	Min	Typ	Max	Units
<b>STARTUP REGULATOR</b>						
VccReg	Vcc Regulator Output		<b>6.85</b>	7.15	<b>7.45</b>	V
	Vcc LDO Mode turn-off			9		V
	Vcc Current Limit	Vcc = 0V		25		mA
<b>VCC SUPPLY</b>						
	Vcc UVLO Threshold	(Vcc increasing)	<b>5.03</b>	5.35	<b>5.67</b>	V
	Vcc Undervoltage Hysteresis			0.35		V
	Bias Current (lin)	FB = 1.3V		3.7	<b>4.5</b>	mA
	Shutdown Current (lin)	SD = 0V		57	<b>85</b>	$\mu\text{A}$
<b>SHUTDOWN THRESHOLDS</b>						
	Shutdown Threshold	(SD Increasing)	<b>0.47</b>	0.7	<b>0.9</b>	V
	Shutdown Hysteresis			0.1		V
	Standby Threshold	(Standby Increasing)	<b>1.17</b>	1.225	<b>1.28</b>	V
	Standby Hysteresis			0.1		V
	SD Pull-up Current Source			5		$\mu\text{A}$
<b>SWITCH CHARACTERISTICS</b>						
	Buck Switch Rds(on)			330	<b>660</b>	m $\Omega$
	BOOST UVLO			4		V
	BOOST UVLO Hysteresis			0.56		V
	Pre-charge Switch Rds(on)			70		$\Omega$
	Pre-charge Switch on-time			250		ns
<b>CURRENT LIMIT</b>						
	Cycle by Cycle Current Limit	RAMP = 0V	<b>1.8</b>	2.1	<b>2.5</b>	A
	Cycle by Cycle Current Limit Delay	RAMP = 2.5V		85		ns
<b>SOFT-START</b>						
	SS Current Source		<b>7</b>	10	<b>14</b>	$\mu\text{A}$
<b>OSCILLATOR</b>						
	Frequency1		<b>180</b>	200	<b>220</b>	kHz
	Frequency2	$R_T = 11\text{k}\Omega$	<b>425</b>	485	<b>545</b>	kHz
	SYNC Source Impedance			11		k $\Omega$
	SYNC Sink Impedance			110		$\Omega$
	SYNC Threshold (falling)			1.3		V
	SYNC Frequency	$R_T = 11\text{k}\Omega$	<b>550</b>			kHz
	SYNC Pulse Width Minimum		<b>15</b>			ns
<b>RAMP GENERATOR</b>						
	Ramp Current 1	Vin = 60V, Vout=10V	<b>467</b>	550	<b>633</b>	$\mu\text{A}$
	Ramp Current 2	Vin = 10V, Vout=10V	<b>36</b>	50	<b>64</b>	$\mu\text{A}$
<b>PWM COMPARATOR</b>						
	Forced Off-time		<b>416</b>	500	<b>575</b>	ns
	Min On-time			80		ns
	COMP to PWM Comparator Offset			0.7		V

(1) Min and Max limits are 100% production tested at  $25^\circ\text{C}$ . Limits over the operating temperature range are ensured through correlation using Statistical Quality Control (SQC) methods. Limits are used to calculate Texas Instruments' Average Outgoing Quality Level (AOQL).

## Electrical Characteristics (continued)

Specifications with standard typeface are for  $T_J = 25^\circ\text{C}$ , and those with **boldface** type apply over full **Operating Junction Temperature range**.  $V_{IN} = 48\text{V}$ ,  $R_T = 32.4\text{k}\Omega$  unless otherwise stated.<sup>(1)</sup>

Symbol	Parameter	Conditions	Min	Typ	Max	Units
<b>ERROR AMPLIFIER</b>						
	Feedback Voltage	$V_{fb} = \text{COMP}$	<b>1.207</b>	1.225	<b>1.243</b>	V
	FB Bias Current			17		nA
	DC Gain			70		dB
	COMP Sink / Source Current		<b>3</b>			mA
	Unity Gain Bandwidth			3		MHz
<b>DIODE SENSE RESISTANCE</b>						
$D_{\text{SENSE}}$				83		m $\Omega$
<b>THERMAL SHUTDOWN</b>						
$T_{sd}$	Thermal Shutdown Threshold			165		$^\circ\text{C}$
	Thermal Shutdown Hysteresis			25		$^\circ\text{C}$
<b>THERMAL RESISTANCE</b>						
$\theta_{JC}$	Junction to Case			14		$^\circ\text{C}/\text{W}$
$\theta_{JA}$	Junction to Ambient			50		$^\circ\text{C}/\text{W}$

Typical Performance Characteristics

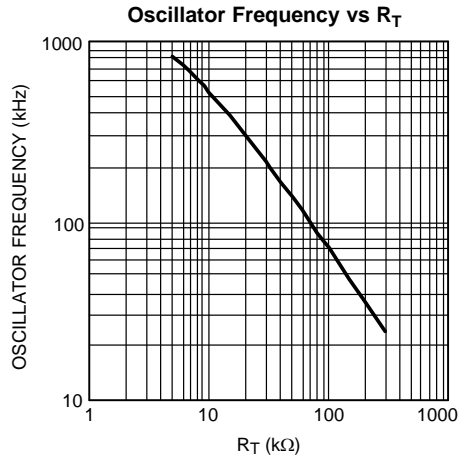

Figure 2.

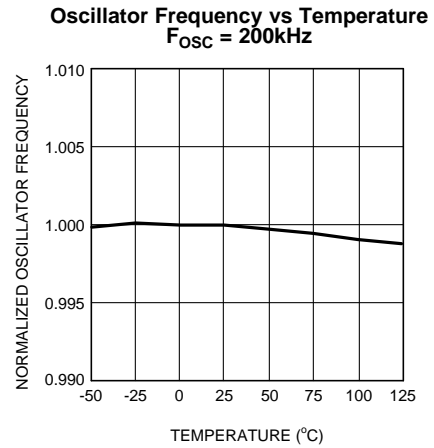

Figure 3.

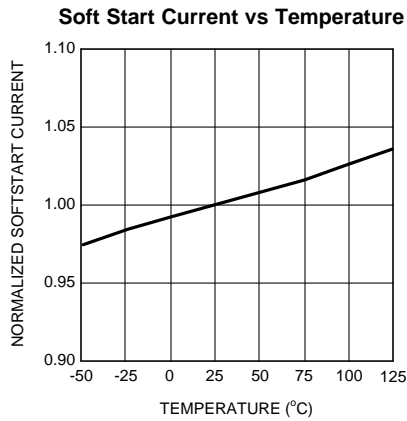

Figure 4.

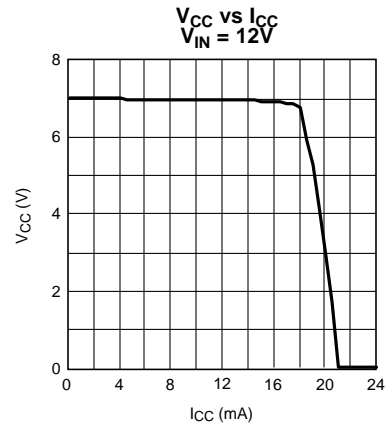

Figure 5.

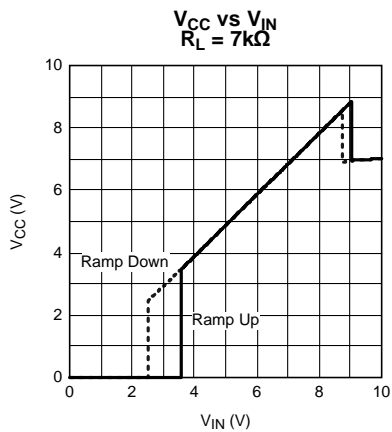

Figure 6.

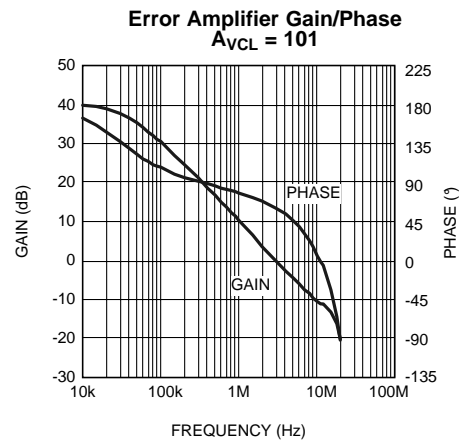

Figure 7.

Typical Performance Characteristics (continued)

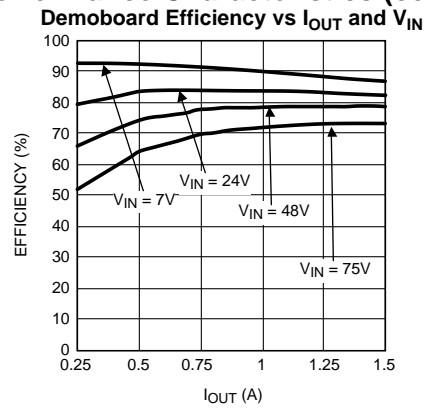

Figure 8.

## TYPICAL APPLICATION CIRCUIT AND BLOCK DIAGRAM

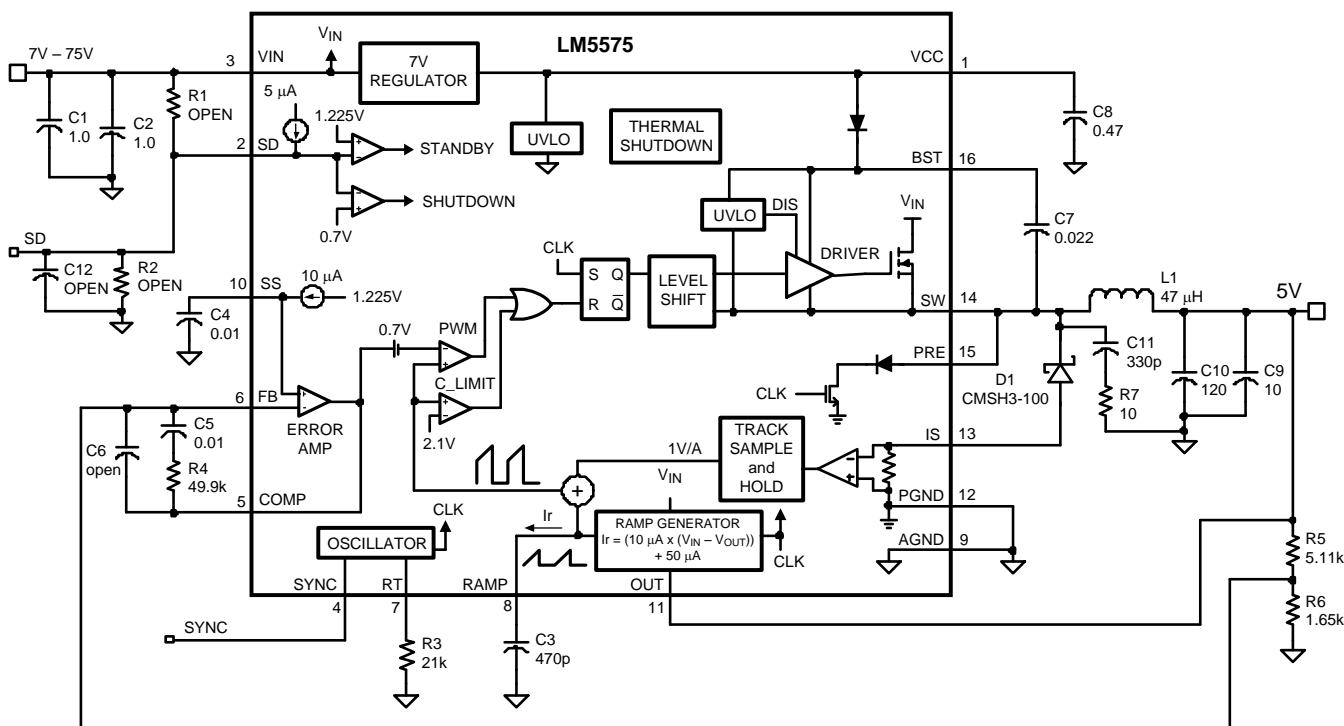

Figure 9. Functional Block Diagram

### Detailed Operating Description

The LM5575 switching regulator features all of the functions necessary to implement an efficient high voltage buck regulator using a minimum of external components. This easy to use regulator integrates a 75V N-Channel buck switch with an output current capability of 1.5 Amps. The regulator control method is based on current mode control utilizing an emulated current ramp. Peak current mode control provides inherent line voltage feed-forward, cycle-by-cycle current limiting, and ease of loop compensation. The use of an emulated control ramp reduces noise sensitivity of the pulse-width modulation circuit, allowing reliable processing of very small duty cycles necessary in high input voltage applications. The operating frequency is user programmable from 50kHz to 500kHz. An oscillator synchronization pin allows multiple LM5575 regulators to self synchronize or be synchronized to an external clock. The output voltage can be set as low as 1.225V. Fault protection features include, current limiting, thermal shutdown and remote shutdown capability. The device is available in the HTSSOP-16 package featuring an exposed pad to aid thermal dissipation.

The functional block diagram and typical application of the LM5575 are shown in Figure 9. The LM5575 can be applied in numerous applications to efficiently step-down a high, unregulated input voltage. The device is well suited for telecom, industrial and automotive power bus voltage ranges.

### High Voltage Start-Up Regulator

The LM5575 contains a dual-mode internal high voltage startup regulator that provides the Vcc bias supply for the PWM controller and boot-strap MOSFET gate driver. The input pin (VIN) can be connected directly to the input voltage, as high as 75 Volts. For input voltages below 9V, a low dropout switch connects Vcc directly to Vin. In this supply range, Vcc is approximately equal to Vin. For Vin voltage greater than 9V, the low dropout switch is disabled and the Vcc regulator is enabled to maintain Vcc at approximately 7V. The wide operating range of 6V to 75V is achieved through the use of this dual mode regulator.

The output of the Vcc regulator is current limited to 25mA. Upon power up, the regulator sources current into the capacitor connected to the VCC pin. When the voltage at the VCC pin exceeds the Vcc UVLO threshold of 5.35V and the SD pin is greater than 1.225V, the output switch is enabled and a soft-start sequence begins. The output switch remains enabled until Vcc falls below 5.0V or the SD pin falls below 1.125V.



An auxiliary supply voltage can be applied to the Vcc pin to reduce the IC power dissipation. If the auxiliary voltage is greater than 7.3V, the internal regulator will essentially shut off, reducing the IC power dissipation. The Vcc regulator series pass transistor includes a diode between Vcc and Vin that should not be forward biased in normal operation. Therefore the auxiliary Vcc voltage should never exceed the Vin voltage.

In high voltage applications extra care should be taken to ensure the VIN pin does not exceed the absolute maximum voltage rating of 76V. During line or load transients, voltage ringing on the Vin line that exceeds the Absolute Maximum Ratings can damage the IC. Both careful PC board layout and the use of quality bypass capacitors located close to the VIN and GND pins are essential.

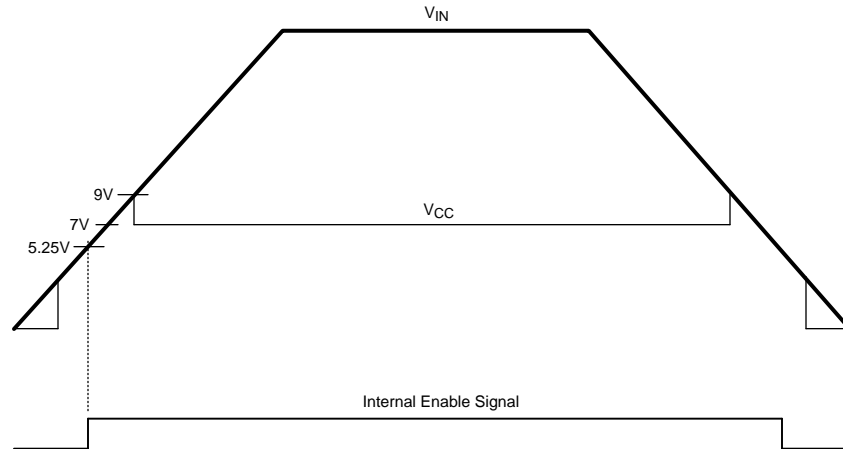

Figure 10. Vin and Vcc Sequencing

### Shutdown / Standby

The LM5575 contains a dual level Shutdown (SD) circuit. When the SD pin voltage is below 0.7V, the regulator is in a low current shutdown mode. When the SD pin voltage is greater than 0.7V but less than 1.225V, the regulator is in standby mode. In standby mode the Vcc regulator is active but the output switch is disabled. When the SD pin voltage exceeds 1.225V, the output switch is enabled and normal operation begins. An internal 5µA pull-up current source configures the regulator to be fully operational if the SD pin is left open.

An external set-point voltage divider from VIN to GND can be used to set the operational input range of the regulator. The divider must be designed such that the voltage at the SD pin will be greater than 1.225V when Vin is in the desired operating range. The internal 5µA pull-up current source must be included in calculations of the external set-point divider. Hysteresis of 0.1V is included for both the shutdown and standby thresholds. The SD pin is internally clamped with a 1kΩ resistor and an 8V zener clamp. The voltage at the SD pin should never exceed 14V. If the voltage at the SD pin exceeds 8V, the bias current will increase at a rate of 1 mA/V.

The SD pin can also be used to implement various remote enable / disable functions. Pulling the SD pin below the 0.7V threshold totally disables the controller. If the SD pin voltage is above 1.225V the regulator will be operational.

### Oscillator and Sync Capability

The LM5575 oscillator frequency is set by a single external resistor connected between the RT pin and the AGND pin. The RT resistor should be located very close to the device and connected directly to the pins of the IC (RT and AGND). To set a desired oscillator frequency (F), the necessary value for the RT resistor can be calculated from the following equation:

$$R_T = \frac{\frac{1}{F} - 580 \times 10^{-9}}{135 \times 10^{-12}} \quad (1)$$

The SYNC pin can be used to synchronize the internal oscillator to an external clock. The external clock must be of **higher frequency** than the free-running frequency set by the RT resistor. A clock circuit with an open drain output is the recommended interface from the external clock to the SYNC pin. The clock pulse duration should be greater than 15ns.

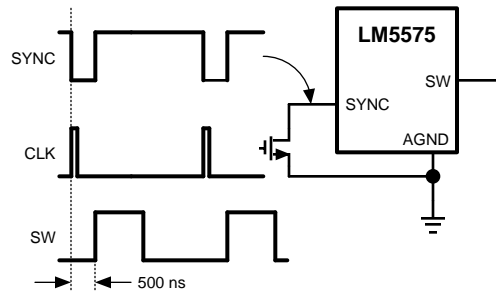

Figure 11. Sync from External Clock

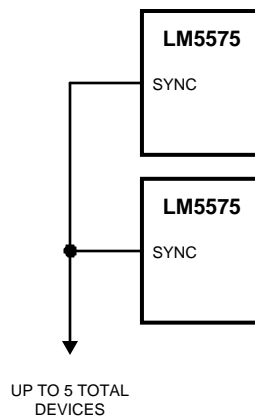

Figure 12. Sync from Multiple Devices

Multiple LM5575 devices can be synchronized together simply by connecting the SYNC pins together. In this configuration all of the devices will be synchronized to the highest frequency device. The diagram in Figure 13 illustrates the SYNC input/output features of the LM5575. The internal oscillator circuit drives the SYNC pin with a strong pull-down / weak pull-up inverter. When the SYNC pin is pulled low either by the internal oscillator or an external clock, the ramp cycle of the oscillator is terminated and a new oscillator cycle begins. Thus, if the SYNC pins of several LM5575 IC's are connected together, the IC with the highest internal clock frequency will pull the connected SYNC pins low first and terminate the oscillator ramp cycles of the other IC's. The LM5575 with the highest programmed clock frequency will serve as the master and control the switching frequency of the all the devices with lower oscillator frequency.

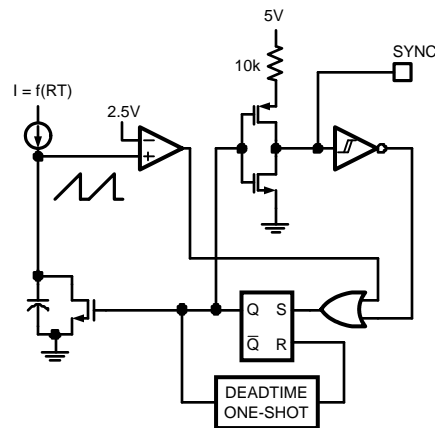

Figure 13. Simplified Oscillator Block Diagram and SYNC I/O Circuit

## Error Amplifier and PWM Comparator

The internal high gain error amplifier generates an error signal proportional to the difference between the regulated output voltage and an internal precision reference (1.225V). The output of the error amplifier is connected to the COMP pin allowing the user to provide loop compensation components, generally a type II network, as illustrated in Figure 9. This network creates a pole at DC, a zero and a noise reducing high frequency pole. The PWM comparator compares the emulated current sense signal from the RAMP generator to the error amplifier output voltage at the COMP pin.

## RAMP Generator

The ramp signal used in the pulse width modulator for current mode control is typically derived directly from the buck switch current. This switch current corresponds to the positive slope portion of the output inductor current. Using this signal for the PWM ramp simplifies the control loop transfer function to a single pole response and provides inherent input voltage feed-forward compensation. The disadvantage of using the buck switch current signal for PWM control is the large leading edge spike due to circuit parasitics that must be filtered or blanked. Also, the current measurement may introduce significant propagation delays. The filtering, blanking time and propagation delay limit the minimum achievable pulsewidth. In applications where the input voltage may be relatively large in comparison to the output voltage, controlling small pulsewidths and duty cycles is necessary for regulation. The LM5575 utilizes a unique ramp generator, which does not actually measure the buck switch current but rather reconstructs the signal. Reconstructing or emulating the inductor current provides a ramp signal to the PWM comparator that is free of leading edge spikes and measurement or filtering delays. The current reconstruction is comprised of two elements; a sample & hold DC level and an emulated current ramp.

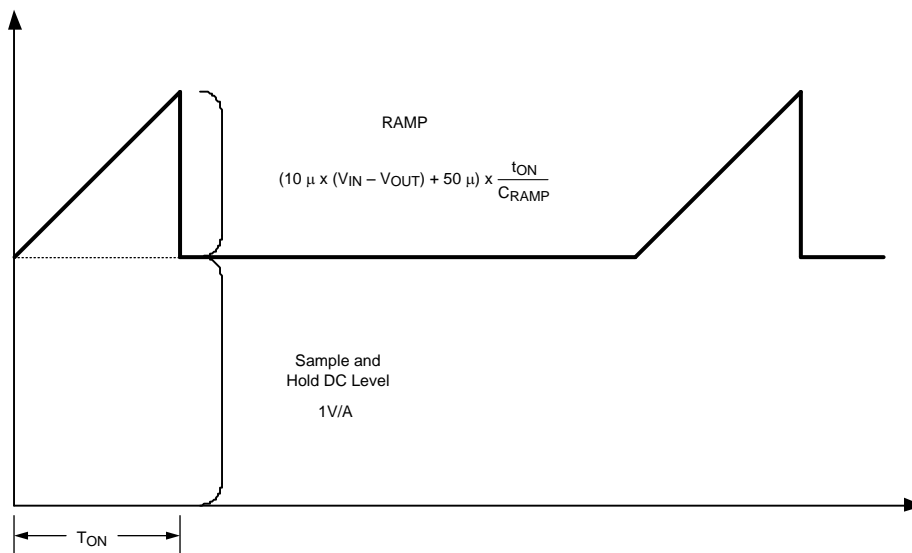

Figure 14. Composition of Current Sense Signal

The sample & hold DC level illustrated in Figure 14 is derived from a measurement of the re-circulating Schottky diode anode current. The re-circulating diode anode should be connected to the IS pin. The diode current flows through an internal current sense resistor between the IS and PGND pins. The voltage level across the sense resistor is sampled and held just prior to the onset of the next conduction interval of the buck switch. The diode current sensing and sample & hold provide the DC level of the reconstructed current signal. The positive slope inductor current ramp is emulated by an external capacitor connected from the RAMP pin to AGND and an internal voltage controlled current source. The ramp current source that emulates the inductor current is a function of the  $V_{in}$  and  $V_{out}$  voltages per the following equation:

$$I_{RAMP} = (10\mu \times (V_{in} - V_{out})) + 50\mu A \quad (2)$$

Proper selection of the RAMP capacitor depends upon the selected value of the output inductor. The value of  $C_{RAMP}$  can be selected from:  $C_{RAMP} = L \times 10^{-5}$ , where L is the value of the output inductor in Henrys. With this value, the scale factor of the emulated current ramp will be approximately equal to the scale factor of the DC level sample and hold (1.0 V / A). The  $C_{RAMP}$  capacitor should be located very close to the device and connected directly to the pins of the IC (RAMP and AGND).

For duty cycles greater than 50%, peak current mode control circuits are subject to sub-harmonic oscillation. Sub-harmonic oscillation is normally characterized by observing alternating wide and narrow pulses at the switch node. Adding a fixed slope voltage ramp (slope compensation) to the current sense signal prevents this oscillation. The 50 $\mu$ A of offset current provided from the emulated current source adds some fixed slope to the ramp signal. In some high output voltage, high duty cycle applications, additional slope may be required. In these applications, a pull-up resistor may be added between the  $V_{CC}$  and RAMP pins to increase the ramp slope compensation.

For  $V_{OUT} > 7.5V$ :

Calculate optimal slope current,  $I_{OS} = V_{OUT} \times 10\mu A/V$ .

For example, at  $V_{OUT} = 10V$ ,  $I_{OS} = 100\mu A$ .

Install a resistor from the RAMP pin to  $V_{CC}$ :

$$R_{RAMP} = V_{CC} / (I_{OS} - 50\mu A)$$

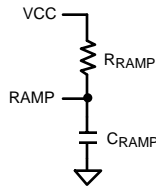

**Figure 15.  $R_{RAMP}$  to  $V_{CC}$  for  $V_{OUT} > 7.5V$**

### Maximum Duty Cycle / Input Drop-out Voltage

There is a forced off-time of 500ns implemented each cycle to ensure sufficient time for the diode current to be sampled. This forced off-time limits the maximum duty cycle of the buck switch. The maximum duty cycle will vary with the operating frequency.

$$D_{MAX} = 1 - F_s \times 500ns \quad (3)$$

Where  $F_s$  is the oscillator frequency. Limiting the maximum duty cycle will raise the input dropout voltage. The input dropout voltage is the lowest input voltage required to maintain regulation of the output voltage. An approximation of the input dropout voltage is:

$$V_{inMIN} = \frac{V_{out} + V_D}{1 - F_s \times 500 ns} \quad (4)$$

Where  $V_D$  is the voltage drop across the re-circulatory diode. Operating at high switching frequency raises the minimum input voltage necessary to maintain regulation.

### Current Limit

The LM5575 contains a unique current monitoring scheme for control and over-current protection. When set correctly, the emulated current sense signal provides a signal which is proportional to the buck switch current with a scale factor of 1.0 V / A. The emulated ramp signal is applied to the current limit comparator. If the emulated ramp signal exceeds 2.1V (2.1A) the present current cycle is terminated (cycle-by-cycle current limiting). In applications with small output inductance and high input voltage the switch current may overshoot due to the propagation delay of the current limit comparator. If an overshoot should occur, the diode current sampling circuit will detect the excess inductor current during the off-time of the buck switch. If the sample & hold DC level exceeds the 2.1V current limit threshold, the buck switch will be disabled and skip pulses until the diode current sampling circuit detects the inductor current has decayed below the current limit threshold. This approach prevents current runaway conditions due to propagation delays or inductor saturation since the inductor current is forced to decay following any current overshoot.

## Soft-Start

The soft-start feature allows the regulator to gradually reach the initial steady state operating point, thus reducing start-up stresses and surges. The internal soft-start current source, set to 10 $\mu$ A, gradually increases the voltage of an external soft-start capacitor connected to the SS pin. The soft-start capacitor voltage is connected to the reference input of the error amplifier. Various sequencing and tracking schemes can be implemented using external circuits that limit or clamp the voltage level of the SS pin.

In the event a fault is detected (over-temperature, V<sub>CC</sub> UVLO, SD) the soft-start capacitor will be discharged. When the fault condition is no longer present a new soft-start sequence will commence.

## Boost Pin

The LM5575 integrates an N-Channel buck switch and associated floating high voltage level shift / gate driver. This gate driver circuit works in conjunction with an internal diode and an external bootstrap capacitor. A 0.022 $\mu$ F ceramic capacitor, connected with short traces between the BST pin and SW pin, is recommended. During the off-time of the buck switch, the SW pin voltage is approximately -0.5V and the bootstrap capacitor is charged from V<sub>CC</sub> through the internal bootstrap diode. When operating with a high PWM duty cycle, the buck switch will be forced off each cycle for 500ns to ensure that the bootstrap capacitor is recharged.

Under very light load conditions or when the output voltage is pre-charged, the SW voltage will not remain low during the off-time of the buck switch. If the inductor current falls to zero and the SW pin rises, the bootstrap capacitor will not receive sufficient voltage to operate the buck switch gate driver. For these applications, the PRE pin can be connected to the SW pin to pre-charge the bootstrap capacitor. The internal pre-charge MOSFET and diode connected between the PRE pin and PGND turns on each cycle for 250ns just prior to the onset of a new switching cycle. If the SW pin is at a normal negative voltage level (continuous conduction mode), then no current will flow through the pre-charge MOSFET/diode.

## Thermal Protection

Internal Thermal Shutdown circuitry is provided to protect the integrated circuit in the event the maximum junction temperature is exceeded. When activated, typically at 165°C, the controller is forced into a low power reset state, disabling the output driver and the bias regulator. This feature is provided to prevent catastrophic failures from accidental device overheating.

## Application Information

### EXTERNAL COMPONENTS

The procedure for calculating the external components is illustrated with the following design example. The Bill of Materials for this design is listed in [Table 1](#). The circuit shown in [Figure 9](#) is configured for the following specifications:

- V<sub>OUT</sub> = 5V
- V<sub>IN</sub> = 7V to 75V
- F<sub>S</sub> = 300kHz
- Minimum load current (for CCM) = 200mA
- Maximum load current = 1.5A

### R<sub>T</sub> (R<sub>T</sub>)

R<sub>T</sub> sets the oscillator switching frequency. Generally, higher frequency applications are smaller but have higher losses. Operation at 300kHz was selected for this example as a reasonable compromise for both small size and high efficiency. The value of R<sub>T</sub> for 300kHz switching frequency can be calculated as follows:

$$R_T = \frac{[(1 / 300 \times 10^3) - 580 \times 10^{-9}]}{135 \times 10^{-12}} \quad (5)$$

The nearest standard value of 21k $\Omega$  was chosen for R<sub>T</sub>.

### L1

The inductor value is determined based on the operating frequency, load current, ripple current, and the minimum and maximum input voltage (V<sub>IN(min)</sub>, V<sub>IN(max)</sub>).

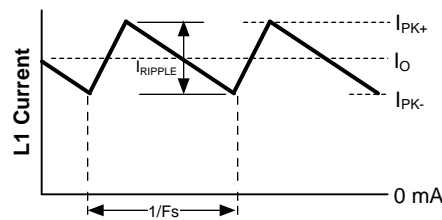

**Figure 16. Inductor Current Waveform**

To keep the circuit in continuous conduction mode (CCM), the maximum ripple current  $I_{\text{RIPPLE}}$  should be less than twice the minimum load current, or  $0.4A_{p-p}$ . Using this value of ripple current, the value of inductor ( $L1$ ) is calculated using the following:

$$L1 = \frac{V_{\text{OUT}} \times (V_{\text{IN(max)}} - V_{\text{OUT}})}{I_{\text{RIPPLE}} \times F_s \times V_{\text{IN(max)}}} \quad (6)$$

$$L1 = \frac{5V \times (75V - 5V)}{0.4A \times 300 \text{ kHz} \times 75V} = 39 \mu\text{H} \quad (7)$$

This procedure provides a guide to select the value of  $L1$ . The nearest standard value ( $47\mu\text{H}$ ) will be used.  $L1$  must be rated for the peak current ( $I_{\text{PK+}}$ ) to prevent saturation. During normal loading conditions, the peak current occurs at maximum load current plus maximum ripple. During an overload condition the peak current is limited to 2.1A nominal (2.5A maximum). The selected inductor (see [Table 1](#)) has a conservative 3.25 Amp saturation current rating. For this manufacturer, the saturation rating is defined as the current necessary for the inductance to reduce by 30%, at 20°C.

### C3 ( $C_{\text{RAMP}}$ )

With the inductor value selected, the value of  $C3$  ( $C_{\text{RAMP}}$ ) necessary for the emulation ramp circuit is:

$$C_{\text{RAMP}} = L \times 10^{-5} \quad (8)$$

Where  $L$  is in Henrys

With  $L1$  selected for  $47\mu\text{H}$  the recommended value for  $C3$  is  $470\text{pF}$ .

### C9, C10

The output capacitors,  $C9$  and  $C10$ , smooth the inductor ripple current and provide a source of charge for transient loading conditions. For this design a  $10\mu\text{F}$  ceramic capacitor and a  $120\mu\text{F}$  AL organic capacitor were selected. The ceramic capacitor provides ultra low ESR to reduce the output ripple voltage and noise spikes, while the AL capacitor provides a large bulk capacitance in a small volume for transient loading conditions. An approximation for the output ripple voltage is:

$$\Delta V_{\text{OUT}} = \Delta I_L \times \left( \text{ESR} + \frac{1}{8 \times F_s \times C_{\text{OUT}}} \right) \quad (9)$$

### D1

A Schottky type re-circulating diode is required for all LM5575 applications. Ultra-fast diodes are not recommended and may result in damage to the IC due to reverse recovery current transients. The near ideal reverse recovery characteristics and low forward voltage drop are particularly important diode characteristics for high input voltage and low output voltage applications common to the LM5575. The reverse recovery characteristic determines how long the current surge lasts each cycle when the buck switch is turned on. The reverse recovery characteristics of Schottky diodes minimize the peak instantaneous power in the buck switch occurring during turn-on each cycle. The resulting switching losses of the buck switch are significantly reduced when using a Schottky diode. The reverse breakdown rating should be selected for the maximum  $V_{\text{IN}}$ , plus some safety margin.

The forward voltage drop has a significant impact on the conversion efficiency, especially for applications with a low output voltage. “Rated” current for diodes vary widely from various manufacturers. The worst case is to assume a short circuit load condition. In this case the diode will carry the output current almost continuously. For the LM5575 this current can be as high as 2.1A. Assuming a worst case 1V drop across the diode, the maximum diode power dissipation can be as high as 2.1W. For the reference design a 100V Schottky in a SMC package was selected.

### C1, C2

The regulator supply voltage has a large source impedance at the switching frequency. Good quality input capacitors are necessary to limit the ripple voltage at the VIN pin while supplying most of the switch current during the on-time. When the buck switch turns on, the current into the VIN pin steps to the lower peak of the inductor current waveform, ramps up to the peak value, then drops to zero at turn-off. The average current into VIN during the on-time is the load current. The input capacitance should be selected for RMS current rating and minimum ripple voltage. A good approximation for the required ripple current rating necessary is  $I_{RMS} > I_{OUT} / 2$ .

Quality ceramic capacitors with a low ESR should be selected for the input filter. To allow for capacitor tolerances and voltage effects, two 1.0 $\mu$ F, 100V ceramic capacitors will be used. If step input voltage transients are expected near the maximum rating of the LM5575, a careful evaluation of ringing and possible spikes at the device VIN pin should be completed. An additional damping network or input voltage clamp may be required in these cases.

### C8

The capacitor at the VCC pin provides noise filtering and stability for the  $V_{CC}$  regulator. The recommended value of C8 should be no smaller than 0.1 $\mu$ F, and should be a good quality, low ESR, ceramic capacitor. A value of 0.47 $\mu$ F was selected for this design.

### C7

The bootstrap capacitor between the BST and the SW pins supplies the gate current to charge the buck switch gate at turn-on. The recommended value of C7 is 0.022 $\mu$ F, and should be a good quality, low ESR, ceramic capacitor.

### C4

The capacitor at the SS pin determines the soft-start time, i.e. the time for the reference voltage and the output voltage, to reach the final regulated value. The time is determined from:

$$t_{ss} = \frac{C4 \times 1.225V}{10 \mu A} \quad (10)$$

For this application, a C4 value of 0.01 $\mu$ F was chosen which corresponds to a soft-start time of 1ms.

### R5, R6

R5 and R6 set the output voltage level, the ratio of these resistors is calculated from:

$$R5/R6 = (V_{OUT} / 1.225V) - 1 \quad (11)$$

For a 5V output, the R5/R6 ratio calculates to 3.082. The resistors should be chosen from standard value resistors, a good starting point is selection in the range of 1.0k $\Omega$  - 10k $\Omega$ . Values of 5.11k $\Omega$  for R5, and 1.65k $\Omega$  for R6 were selected.

### R1, R2, C12

A voltage divider can be connected to the SD pin to set a minimum operating voltage  $V_{IN(min)}$  for the regulator. If this feature is required, the easiest approach to select the divider resistor values is to select a value for R1 (between 10k $\Omega$  and 100k $\Omega$  recommended) then calculate R2 from:

$$R2 = 1.225 \times \left( \frac{R1}{V_{IN(min)} + (5 \times 10^{-6} \times R1) - 1.225} \right) \quad (12)$$



Capacitor C12 provides filtering for the divider. The voltage at the SD pin should never exceed 8V, when using an external set-point divider it may be necessary to clamp the SD pin at high input voltage conditions. The reference design utilizes the full range of the LM5575 (6V to 75V); therefore these components can be omitted. With the SD pin open circuit the LM5575 responds once the V<sub>CC</sub> UVLO threshold is satisfied.

### R7, C11

A snubber network across the power diode reduces ringing and spikes at the switching node. Excessive ringing and spikes can cause erratic operation and couple spikes and noise to the output. Voltage spikes beyond the rating of the LM5575 or the re-circulating diode can damage these devices. Selecting the values for the snubber is best accomplished through empirical methods. First, make sure the lead lengths for the snubber connections are very short. For the current levels typical for the LM5575 a resistor value between 5 and 20 Ohms is adequate. Increasing the value of the snubber capacitor results in more damping but higher losses. Select a minimum value of C11 that provides adequate damping of the SW pin waveform at high load.

### R4, C5, C6

These components configure the error amplifier gain characteristics to accomplish a stable overall loop gain. One advantage of current mode control is the ability to close the loop with only two feedback components, R4 and C5. The overall loop gain is the product of the modulator gain and the error amplifier gain. The DC modulator gain of the LM5575 is as follows:

$$\text{DC Gain}_{(\text{MOD})} = G_{m(\text{MOD})} \times R_{\text{LOAD}} = 1 \times R_{\text{LOAD}} \quad (13)$$

The dominant low frequency pole of the modulator is determined by the load resistance (R<sub>LOAD</sub>) and output capacitance (C<sub>OUT</sub>). The corner frequency of this pole is:

$$f_{p(\text{MOD})} = 1 / (2\pi R_{\text{LOAD}} C_{\text{OUT}}) \quad (14)$$

For R<sub>LOAD</sub> = 5Ω and C<sub>OUT</sub> = 130μF then f<sub>p(MOD)</sub> = 245Hz

$$\text{DC Gain}_{(\text{MOD})} = 1 \times 5 = 14\text{dB}$$

For the design example of [Figure 9](#) the following modulator gain vs. frequency characteristic was measured as shown in [Figure 17](#).

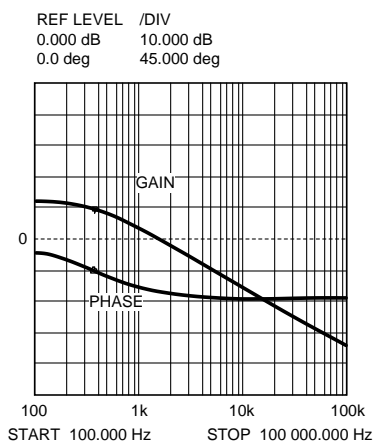

**Figure 17. Gain and Phase of Modulator**  
 R<sub>LOAD</sub> = 5 Ohms and C<sub>OUT</sub> = 130μF



Components R4 and C5 configure the error amplifier as a type II configuration which has a pole at DC and a zero at  $f_z = 1 / (2\pi R4 C5)$ . The error amplifier zero cancels the modulator pole leaving a single pole response at the crossover frequency of the loop gain. A single pole response at the crossover frequency yields a very stable loop with 90 degrees of phase margin.

For the design example, a target loop bandwidth (crossover frequency) of 15kHz was selected. The compensation network zero ( $f_z$ ) should be selected at least an order of magnitude less than the target crossover frequency. This constrains the product of R4 and C5 for a desired compensation network zero  $1 / (2\pi R4 C5)$  to be less than 2kHz. Increasing R4, while proportionally decreasing C5, increases the error amp gain. Conversely, decreasing R4 while proportionally increasing C5, decreases the error amp gain. For the design example C5 was selected for 0.01 $\mu$ F and R4 was selected for 49.9k $\Omega$ . These values configure the compensation network zero at 320Hz. The error amp gain at frequencies greater than  $f_z$  is:  $R4 / R5$ , which is approximately 10 (20dB).

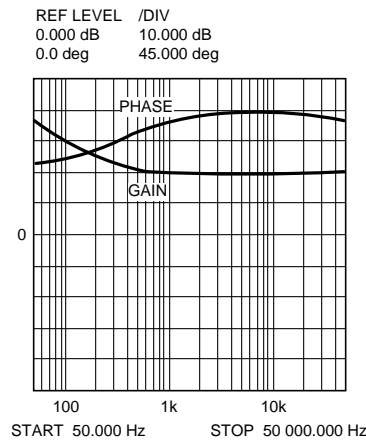

Figure 18. Error Amplifier Gain and Phase

The overall loop can be predicted as the sum (in dB) of the modulator gain and the error amp gain.

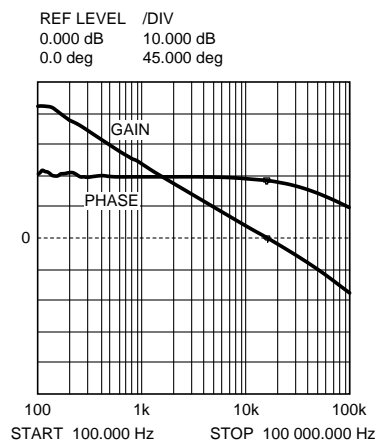

Figure 19. Overall Loop Gain and Phase

If a network analyzer is available, the modulator gain can be measured and the error amplifier gain can be configured for the desired loop transfer function. If a network analyzer is not available, the error amplifier compensation components can be designed with the guidelines given. Step load transient tests can be performed to verify acceptable performance. The step load goal is minimum overshoot with a damped response. C6 can be added to the compensation network to decrease noise susceptibility of the error amplifier. The value of C6 must be sufficiently small since the addition of this capacitor adds a pole in the error amplifier transfer function. This pole must be well beyond the loop crossover frequency. A good approximation of the location of the pole added by C6 is:  $f_{p2} = f_z \times C5 / C6$ .

## BIAS POWER DISSIPATION REDUCTION

Buck regulators operating with high input voltage can dissipate an appreciable amount of power for the bias of the IC. The  $V_{CC}$  regulator must step-down the input voltage  $V_{IN}$  to a nominal  $V_{CC}$  level of 7V. The large voltage drop across the  $V_{CC}$  regulator translates into a large power dissipation within the  $V_{CC}$  regulator. There are several techniques that can significantly reduce this bias regulator power dissipation. Figure 20 and Figure 21 depict two methods to bias the IC from the output voltage. In each case the internal  $V_{CC}$  regulator is used to initially bias the VCC pin. After the output voltage is established, the VCC pin potential is raised above the nominal 7V regulation level, which effectively disables the internal  $V_{CC}$  regulator. The voltage applied to the VCC pin should never exceed 14V. The  $V_{CC}$  voltage should never be larger than the  $V_{IN}$  voltage.

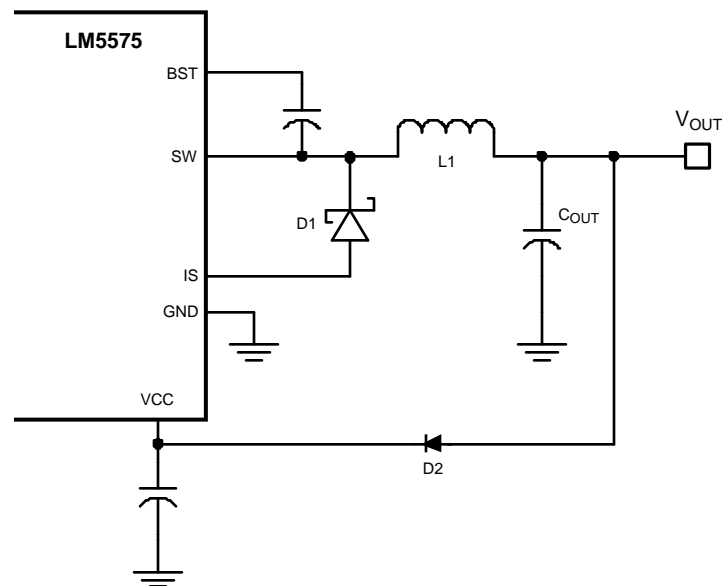

Figure 20. VCC Bias from VOUT for  $8V < V_{OUT} < 14V$

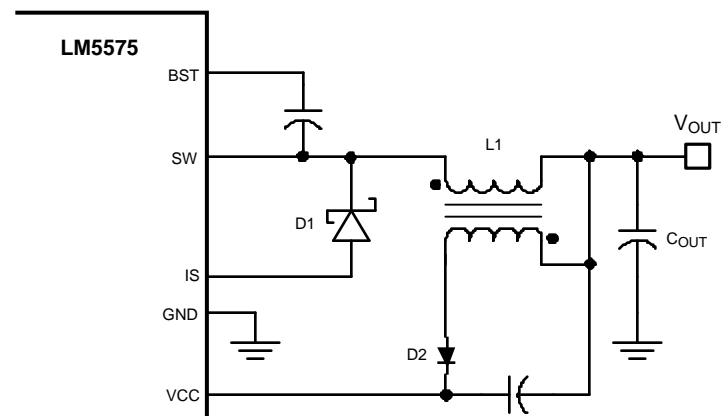

Figure 21. VCC Bias with Additional Winding on the Output Inductor

## PCB LAYOUT AND THERMAL CONSIDERATIONS

The circuit in [Figure 9](#) serves as both a block diagram of the LM5575 and a typical application board schematic for the LM5575. In a buck regulator there are two loops where currents are switched very fast. The first loop starts from the input capacitors, to the regulator VIN pin, to the regulator SW pin, to the inductor then out to the load. The second loop starts from the output capacitor ground, to the regulator PGND pins, to the regulator IS pins, to the diode anode, to the inductor and then out to the load. Minimizing the loop area of these two loops reduces the stray inductance and minimizes noise and possible erratic operation. A ground plane in the PC board is recommended as a means to connect the input filter capacitors to the output filter capacitors and the PGND pins of the regulator. Connect all of the low power ground connections ( $C_{SS}$ ,  $R_T$ ,  $C_{RAMP}$ ) directly to the regulator AGND pin. Connect the AGND and PGND pins together through the topside copper area covering the entire underside of the device. Place several vias in this underside copper area to the ground plane.

The two highest power dissipating components are the re-circulating diode and the LM5575 regulator IC. The easiest method to determine the power dissipated within the LM5575 is to measure the total conversion losses ( $P_{in} - P_{out}$ ) then subtract the power losses in the Schottky diode, output inductor and snubber resistor. An approximation for the Schottky diode loss is  $P = (1-D) \times I_{out} \times V_{fwd}$ . An approximation for the output inductor power is  $P = I_{OUT}^2 \times R \times 1.1$ , where R is the DC resistance of the inductor and the 1.1 factor is an approximation for the AC losses. If a snubber is used, an approximation for the damping resistor power dissipation is  $P = V_{in}^2 \times F_{sw} \times C_{snub}$ , where  $F_{sw}$  is the switching frequency and  $C_{snub}$  is the snubber capacitor. The regulator has an exposed thermal pad to aid power dissipation. Adding several vias under the device to the ground plane will greatly reduce the regulator junction temperature. Selecting a diode with an exposed pad will aid the power dissipation of the diode.

The most significant variables that affect the power dissipated by the LM5575 are the output current, input voltage and operating frequency. The power dissipated while operating near the maximum output current and maximum input voltage can be appreciable. The operating frequency of the LM5575 evaluation board has been designed for 300kHz. When operating at 1.5A output current with a 70V input the power dissipation of the LM5575 regulator is approximately 1.25W.

The junction-to-ambient thermal resistance of the LM5575 will vary with the application. The most significant variables are the area of copper in the PC board, the number of vias under the IC exposed pad and the amount of forced air cooling provided. Referring to the evaluation board artwork, the area under the LM5575 (component side) is covered with copper and there are 5 connection vias to the solder side ground plane. Additional vias under the IC will have diminishing value as more vias are added. The integrity of the solder connection from the IC exposed pad to the PC board is critical. Excessive voids will greatly diminish the thermal dissipation capacity. The junction-to-ambient thermal resistance of the LM5575 mounted in the evaluation board varies from 50°C/W with no airflow to 28°C/W with 900 LFM (Linear Feet per Minute). With a 25°C ambient temperature and no airflow, the predicted junction temperature for the LM5575 will be  $25 + (50 \times 1.25) = 88^\circ\text{C}$ . If the evaluation board is operated at 1.5A output current, 70V input voltage and high ambient temperature for a prolonged period of time the thermal shutdown protection within the IC may activate. The IC will turn off allowing the junction to cool, followed by restart with the soft-start capacitor reset to zero.

**Table 1. 5V, 1.5A Demo Board Bill of Materials**

ITEM		PART NUMBER	DESCRIPTION	VALUE
C	1	C3225X7R2A105M	CAPACITOR, CER, TDK	1 $\mu$ , 100V
C	2	C3225X7R2A105M	CAPACITOR, CER, TDK	1 $\mu$ , 100V
C	3	C0805A471K1GAC	CAPACITOR, CER, KEMET	470p, 100V
C	4	C2012X7R2A103K	CAPACITOR, CER, TDK	0.01 $\mu$ , 100V
C	5	C2012X7R2A103K	CAPACITOR, CER, TDK	0.01 $\mu$ , 100V
C	6	OPEN	NOT USED	
C	7	C2012X7R2A223K	CAPACITOR, CER, TDK	0.022 $\mu$ , 100V
C	8	C2012X7R1C474M	CAPACITOR, CER, TDK	0.47 $\mu$ , 16V
C	9	C3225X7R1C106M	CAPACITOR, CER, TDK	10 $\mu$ , 16V
C	10	APXE6R3ARA121ME61G	CAPACITOR, AL, NIPPON	120 $\mu$ , 6.3V
C	11	C0805C331G1GAC	CAPACITOR, CER, KEMET	330p, 100V
C	12	OPEN	NOT USED	
D	1	CMSH3-100	DIODE, 100V, CENTRAL	
L	1	DR125-470	INDUCTOR, COOPER	47 $\mu$ H
R	1	OPEN	NOT USED	
R	2	OPEN	NOT USED	
R	3	CRCW08052102F	RESISTOR	21k $\Omega$
R	4	CRCW08054992F	RESISTOR	49.9k $\Omega$
R	5	CRCW08055111F	RESISTOR	5.11k $\Omega$
R	6	CRCW08051651F	RESISTOR	1.65k $\Omega$
R	7	CRCW2512100J	RESISTOR	10, 1W
U	1	LM5575	REGULATOR, TEXAS INSTRUMENTS	

PCB Layout

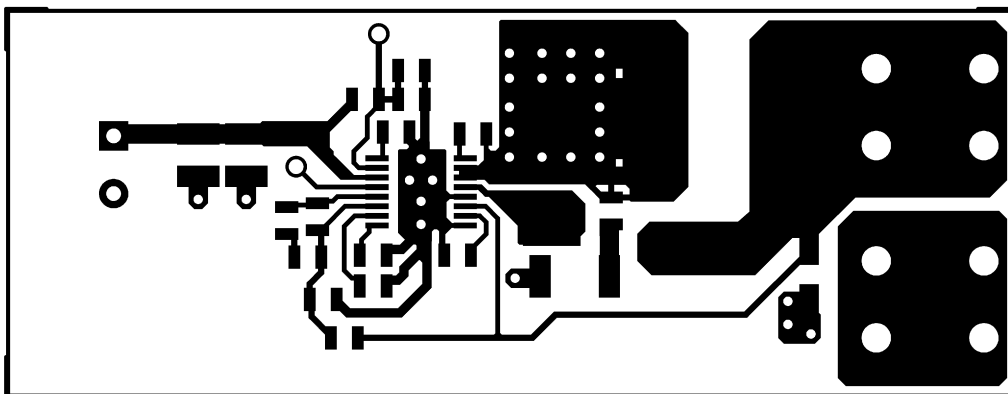

Figure 22. Component Side

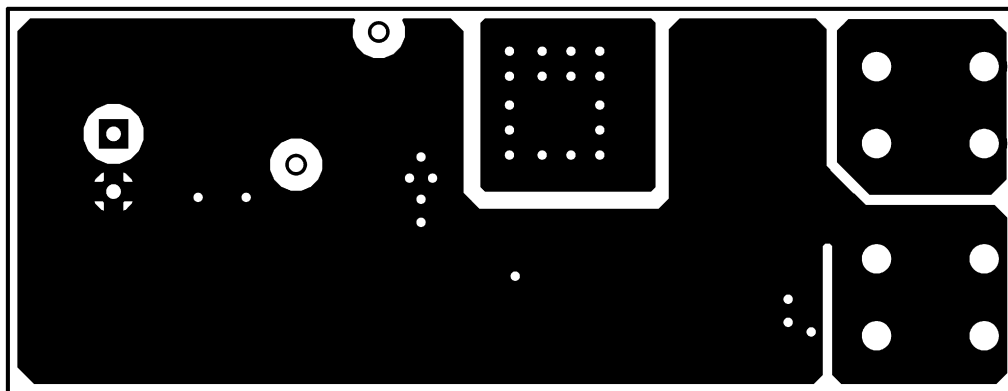

Figure 23. Solder Side

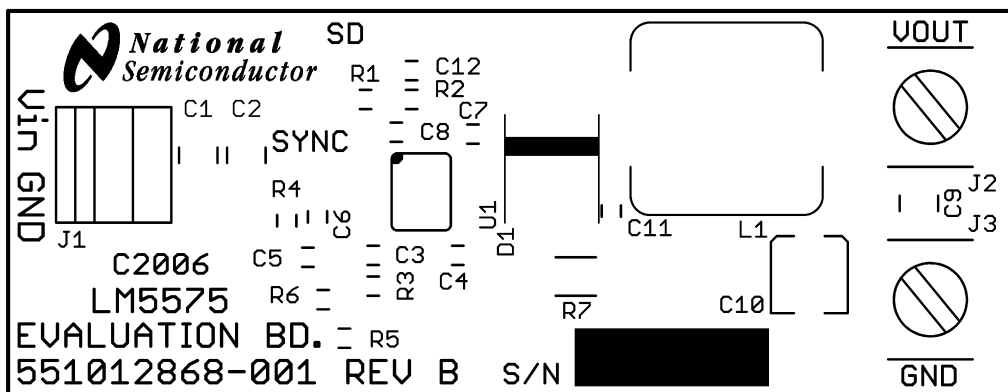

Figure 24. Silkscreen

### REVISION HISTORY

Changes from Revision F (April 2013) to Revision G	Page
• Changed layout of National Data Sheet to TI format .....	<a href="#">21</a>

**PACKAGING INFORMATION**

Orderable Device	Status (1)	Package Type	Package Drawing	Pins	Package Qty	Eco Plan (2)	Lead finish/ Ball material (6)	MSL Peak Temp (3)	Op Temp (°C)	Device Marking (4/5)	Samples
LM5575MH	LIFEBUY	HTSSOP	PWP	16	92	Non-RoHS & Green	Call TI	Level-1-260C-UNLIM	-40 to 125	LM5575 MH	
LM5575MH/NOPB	ACTIVE	HTSSOP	PWP	16	92	RoHS & Green	SN	Level-1-260C-UNLIM	-40 to 125	LM5575 MH	Samples
LM5575MHX/NOPB	ACTIVE	HTSSOP	PWP	16	2500	RoHS & Green	SN	Level-1-260C-UNLIM	-40 to 125	LM5575 MH	Samples
LM5575Q0MH/NOPB	ACTIVE	HTSSOP	PWP	16	92	RoHS & Green	SN	Level-1-260C-UNLIM	-40 to 150	LM5575 Q0MH	Samples
LM5575Q0MHX/NOPB	ACTIVE	HTSSOP	PWP	16	2500	RoHS & Green	SN	Level-1-260C-UNLIM	-40 to 150	LM5575 Q0MH	Samples
LM5575QMH/NOPB	ACTIVE	HTSSOP	PWP	16	92	RoHS & Green	SN	Level-1-260C-UNLIM	-40 to 125	LM5575 QMH	Samples
LM5575QMHX/NOPB	ACTIVE	HTSSOP	PWP	16	2500	RoHS & Green	SN	Level-1-260C-UNLIM	-40 to 125	LM5575 QMH	Samples

(1) The marketing status values are defined as follows:

**ACTIVE:** Product device recommended for new designs.

**LIFEBUY:** TI has announced that the device will be discontinued, and a lifetime-buy period is in effect.

**NRND:** Not recommended for new designs. Device is in production to support existing customers, but TI does not recommend using this part in a new design.

**PREVIEW:** Device has been announced but is not in production. Samples may or may not be available.

**OBSOLETE:** TI has discontinued the production of the device.

(2) **RoHS:** TI defines "RoHS" to mean semiconductor products that are compliant with the current EU RoHS requirements for all 10 RoHS substances, including the requirement that RoHS substance do not exceed 0.1% by weight in homogeneous materials. Where designed to be soldered at high temperatures, "RoHS" products are suitable for use in specified lead-free processes. TI may reference these types of products as "Pb-Free".

**RoHS Exempt:** TI defines "RoHS Exempt" to mean products that contain lead but are compliant with EU RoHS pursuant to a specific EU RoHS exemption.

**Green:** TI defines "Green" to mean the content of Chlorine (Cl) and Bromine (Br) based flame retardants meet JS709B low halogen requirements of <=1000ppm threshold. Antimony trioxide based flame retardants must also meet the <=1000ppm threshold requirement.

(3) MSL, Peak Temp. - The Moisture Sensitivity Level rating according to the JEDEC industry standard classifications, and peak solder temperature.

(4) There may be additional marking, which relates to the logo, the lot trace code information, or the environmental category on the device.

(5) Multiple Device Markings will be inside parentheses. Only one Device Marking contained in parentheses and separated by a "~" will appear on a device. If a line is indented then it is a continuation of the previous line and the two combined represent the entire Device Marking for that device.

<sup>(6)</sup> Lead finish/Ball material - Orderable Devices may have multiple material finish options. Finish options are separated by a vertical ruled line. Lead finish/Ball material values may wrap to two lines if the finish value exceeds the maximum column width.

**Important Information and Disclaimer:**The information provided on this page represents TI's knowledge and belief as of the date that it is provided. TI bases its knowledge and belief on information provided by third parties, and makes no representation or warranty as to the accuracy of such information. Efforts are underway to better integrate information from third parties. TI has taken and continues to take reasonable steps to provide representative and accurate information but may not have conducted destructive testing or chemical analysis on incoming materials and chemicals. TI and TI suppliers consider certain information to be proprietary, and thus CAS numbers and other limited information may not be available for release.

In no event shall TI's liability arising out of such information exceed the total purchase price of the TI part(s) at issue in this document sold by TI to Customer on an annual basis.

**OTHER QUALIFIED VERSIONS OF LM5575, LM5575-Q1 :**

- Catalog : [LM5575](#)
- Automotive : [LM5575-Q1](#)

NOTE: Qualified Version Definitions:

- Catalog - TI's standard catalog product
- Automotive - Q100 devices qualified for high-reliability automotive applications targeting zero defects



**TAPE AND REEL INFORMATION**

**QUADRANT ASSIGNMENTS FOR PIN 1 ORIENTATION IN TAPE**

\*All dimensions are nominal

Device	Package Type	Package Drawing	Pins	SPQ	Reel Diameter (mm)	Reel Width W1 (mm)	A0 (mm)	B0 (mm)	K0 (mm)	P1 (mm)	W (mm)	Pin1 Quadrant
LM5575MHX/NOPB	HTSSOP	PWP	16	2500	330.0	12.4	6.9	5.6	1.6	8.0	12.0	Q1
LM5575Q0MHX/NOPB	HTSSOP	PWP	16	2500	330.0	12.4	6.9	5.6	1.6	8.0	12.0	Q1
LM5575QMhx/NOPB	HTSSOP	PWP	16	2500	330.0	12.4	6.9	5.6	1.6	8.0	12.0	Q1

**TAPE AND REEL BOX DIMENSIONS**



\*All dimensions are nominal

Device	Package Type	Package Drawing	Pins	SPQ	Length (mm)	Width (mm)	Height (mm)
LM5575MHX/NOPB	HTSSOP	PWP	16	2500	367.0	367.0	35.0
LM5575Q0MHX/NOPB	HTSSOP	PWP	16	2500	367.0	367.0	35.0
LM5575QMhx/NOPB	HTSSOP	PWP	16	2500	367.0	367.0	35.0

**TUBE**

\*All dimensions are nominal

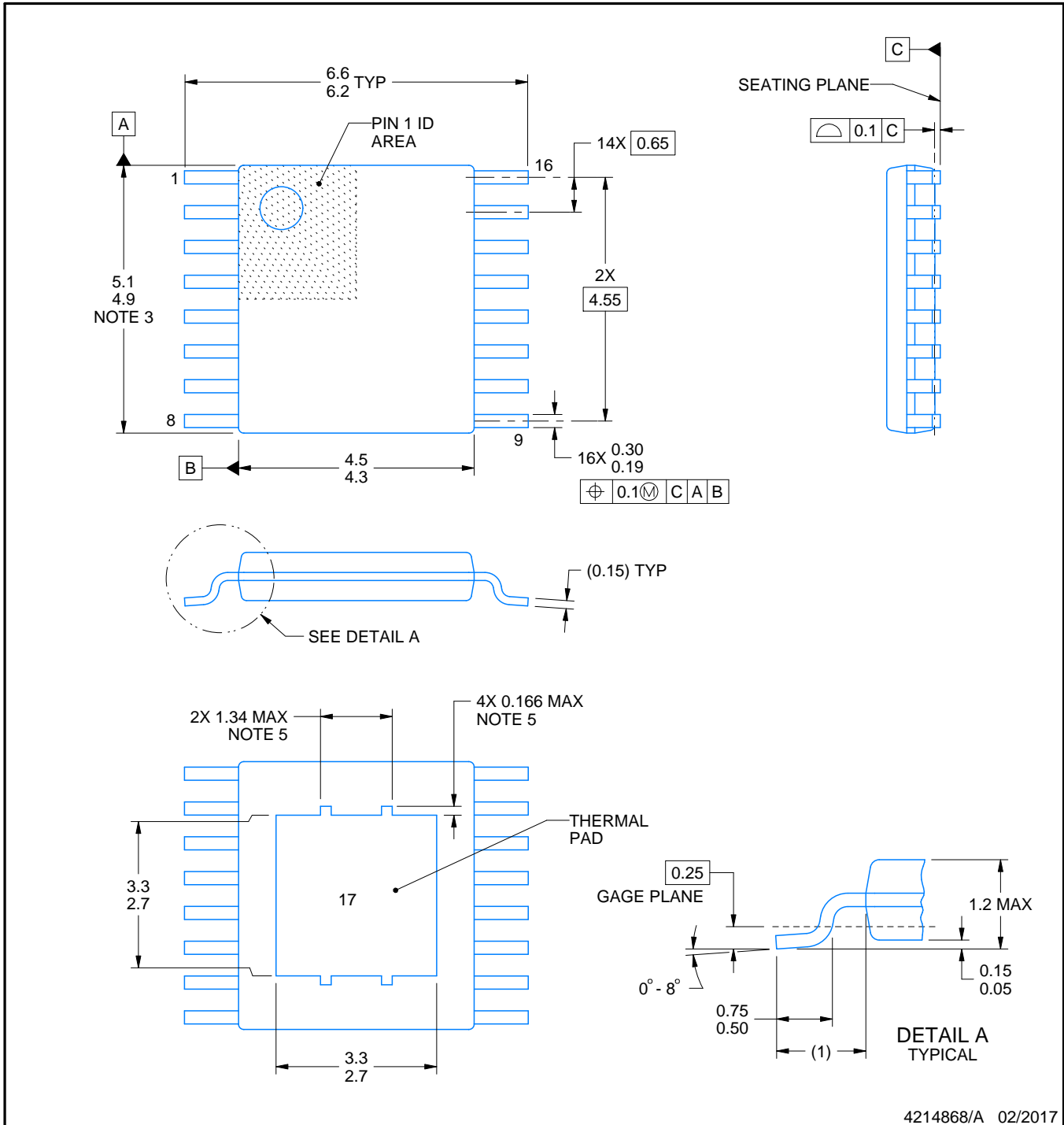
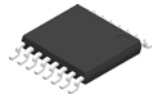
Device	Package Name	Package Type	Pins	SPQ	L (mm)	W (mm)	T (μm)	B (mm)
LM5575MH	PWP	HTSSOP	16	92	495	8	2514.6	4.06
LM5575MH	PWP	HTSSOP	16	92	495	8	2514.6	4.06
LM5575MH/NOPB	PWP	HTSSOP	16	92	495	8	2514.6	4.06
LM5575MH/NOPB	PWP	HTSSOP	16	92	495	8	2514.6	4.06
LM5575Q0MH/NOPB	PWP	HTSSOP	16	92	495	8	2514.6	4.06
LM5575QMH/NOPB	PWP	HTSSOP	16	92	495	8	2514.6	4.06
LM5575QMH/NOPB	PWP	HTSSOP	16	92	495	8	2514.6	4.06



4214868/A 02/2017

NOTES:

PowerPAD is a trademark of Texas Instruments.

1. All linear dimensions are in millimeters. Any dimensions in parenthesis are for reference only. Dimensioning and tolerancing per ASME Y14.5M.
2. This drawing is subject to change without notice.
3. This dimension does not include mold flash, protrusions, or gate burrs. Mold flash, protrusions, or gate burrs shall not exceed 0.15 mm per side.
4. Reference JEDEC registration MO-153.
5. Features may not be present.

# EXAMPLE BOARD LAYOUT

PWP0016A

PowerPAD™ HTSSOP - 1.2 mm max height

PLASTIC SMALL OUTLINE

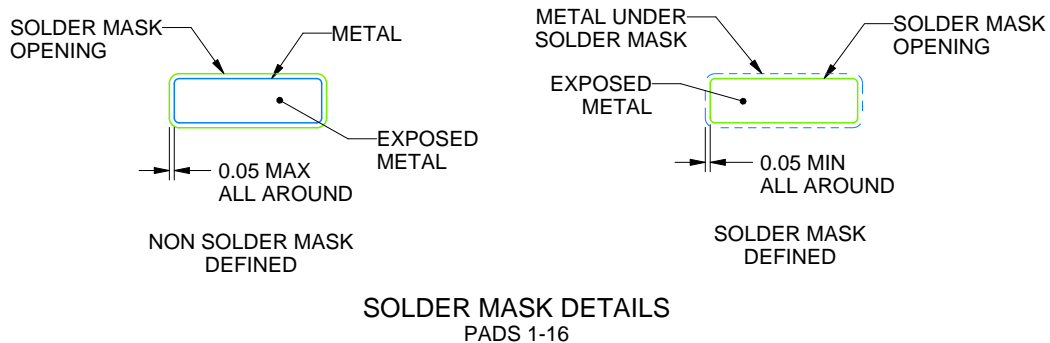
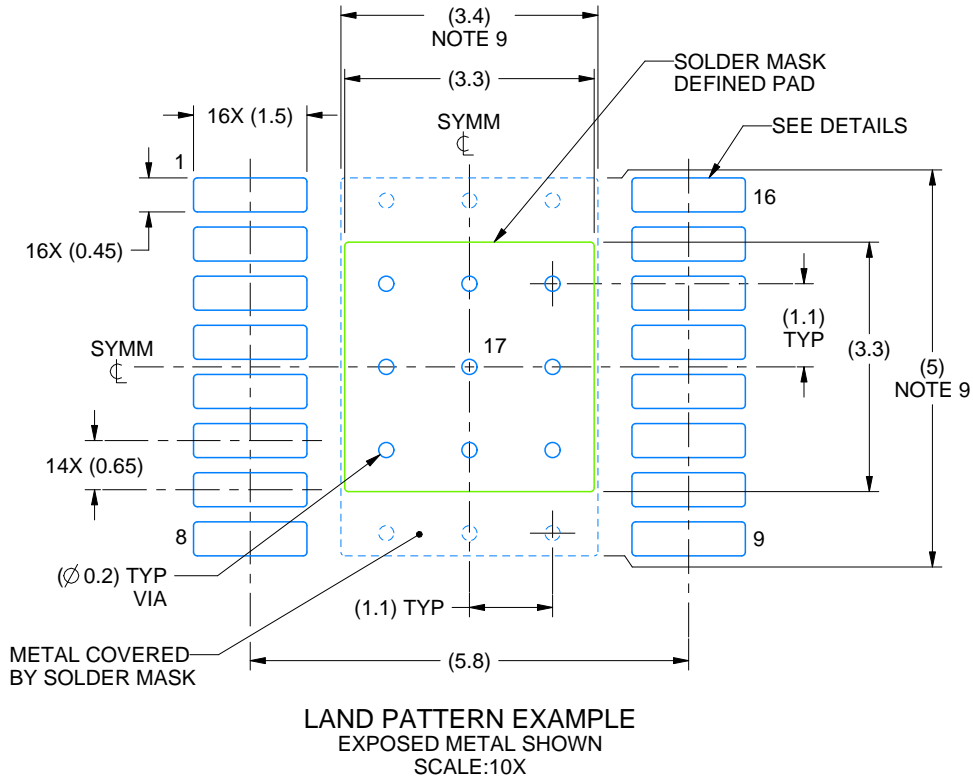

4214868/A 02/2017

NOTES: (continued)

6. Publication IPC-7351 may have alternate designs.
7. Solder mask tolerances between and around signal pads can vary based on board fabrication site.
8. This package is designed to be soldered to a thermal pad on the board. For more information, see Texas Instruments literature numbers SLMA002 ([www.ti.com/lit/slma002](http://www.ti.com/lit/slma002)) and SLMA004 ([www.ti.com/lit/slma004](http://www.ti.com/lit/slma004)).
9. Size of metal pad may vary due to creepage requirement.

# EXAMPLE STENCIL DESIGN

PWP0016A

PowerPAD™ HTSSOP - 1.2 mm max height

PLASTIC SMALL OUTLINE

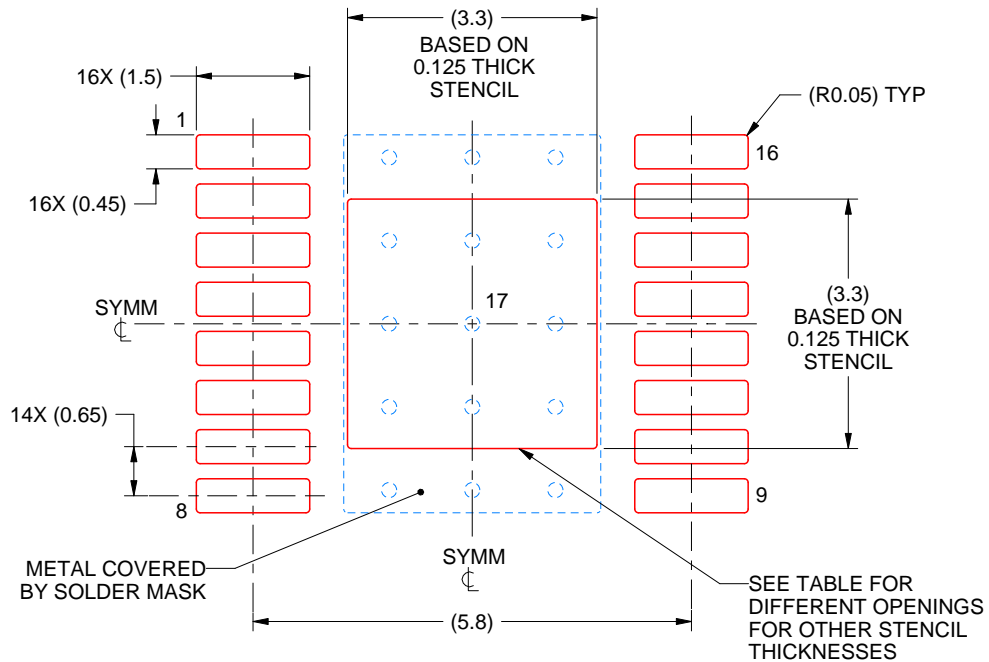

**SOLDER PASTE EXAMPLE**  
 EXPOSED PAD  
 100% PRINTED SOLDER COVERAGE BY AREA  
 SCALE:10X

STENCIL THICKNESS	SOLDER STENCIL OPENING
0.1	3.69 X 3.69
0.125	3.3 X 3.3 (SHOWN)
0.15	3.01 X 3.01
0.175	2.79 X 2.79

4214868/A 02/2017

NOTES: (continued)

10. Laser cutting apertures with trapezoidal walls and rounded corners may offer better paste release. IPC-7525 may have alternate design recommendations.
11. Board assembly site may have different recommendations for stencil design.

## IMPORTANT NOTICE AND DISCLAIMER

TI PROVIDES TECHNICAL AND RELIABILITY DATA (INCLUDING DATA SHEETS), DESIGN RESOURCES (INCLUDING REFERENCE DESIGNS), APPLICATION OR OTHER DESIGN ADVICE, WEB TOOLS, SAFETY INFORMATION, AND OTHER RESOURCES "AS IS" AND WITH ALL FAULTS, AND DISCLAIMS ALL WARRANTIES, EXPRESS AND IMPLIED, INCLUDING WITHOUT LIMITATION ANY IMPLIED WARRANTIES OF MERCHANTABILITY, FITNESS FOR A PARTICULAR PURPOSE OR NON-INFRINGEMENT OF THIRD PARTY INTELLECTUAL PROPERTY RIGHTS.

These resources are intended for skilled developers designing with TI products. You are solely responsible for (1) selecting the appropriate TI products for your application, (2) designing, validating and testing your application, and (3) ensuring your application meets applicable standards, and any other safety, security, regulatory or other requirements.

These resources are subject to change without notice. TI grants you permission to use these resources only for development of an application that uses the TI products described in the resource. Other reproduction and display of these resources is prohibited. No license is granted to any other TI intellectual property right or to any third party intellectual property right. TI disclaims responsibility for, and you will fully indemnify TI and its representatives against, any claims, damages, costs, losses, and liabilities arising out of your use of these resources.

TI's products are provided subject to [TI's Terms of Sale](#) or other applicable terms available either on [ti.com](https://www.ti.com) or provided in conjunction with such TI products. TI's provision of these resources does not expand or otherwise alter TI's applicable warranties or warranty disclaimers for TI products.

TI objects to and rejects any additional or different terms you may have proposed.

Mailing Address: Texas Instruments, Post Office Box 655303, Dallas, Texas 75265  
Copyright © 2024, Texas Instruments Incorporated