



The Future of Analog IC Technology®

MP3202

1.3A Fixed Frequency White LED Driver

DESCRIPTION

The MP3202 is a step-up converter designed for driving up to 39 white LEDs (13 strings of 3 LEDs each) from a 5V system rail. The MP3202 uses a current mode, fixed frequency architecture to regulate the LED current, which is measured through an external current sense resistor. Its low 104mV feedback voltage reduces power loss and improves efficiency. The OV pin monitors the output voltage and turns off the converter if an over-voltage condition is present due to an open circuit condition.

The MP3202 includes under-voltage lockout, current limiting and thermal overload protection preventing damage in the event of an output overload.

The MP3202 is available in small 6-pin TSOT23 or 8-pin QFN (2mm x 2mm) packages.

FEATURES

- 2.5V to 6V Input Voltage Range
- On Board Power MOSFET
- Drives up to 39 White LEDs at 5V Input
- Up to 92% Efficiency
- Over 1MHz Fixed Switching Frequency
- Open Load Shutdown
- Low 104mV Feedback Voltage
- Soft-Start/PWM Dimming
- UVLO, Thermal Shutdown
- Internal 1.3A Current Limit
- Available in TSOT23-6 and QFN8 Packages

APPLICATIONS

- Cell Phones
- Handheld Computers and PDAs
- Digital Still Cameras
- Small LCD Displays

"MPS" and "The Future of Analog IC Technology" are Registered Trademarks of Monolithic Power Systems, Inc.

TYPICAL APPLICATION

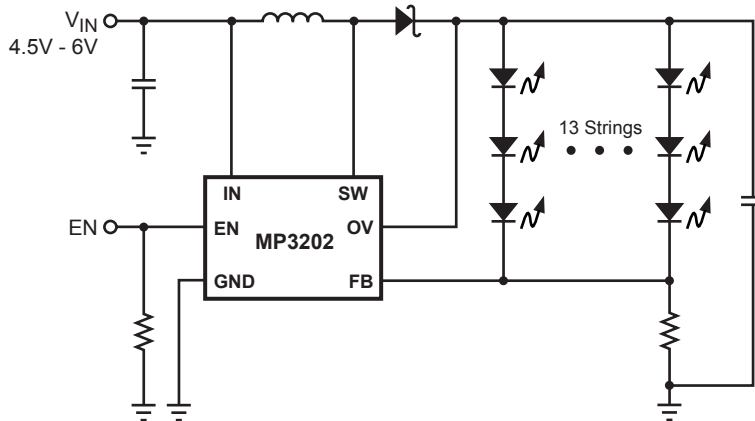

Efficiency vs Input Voltage

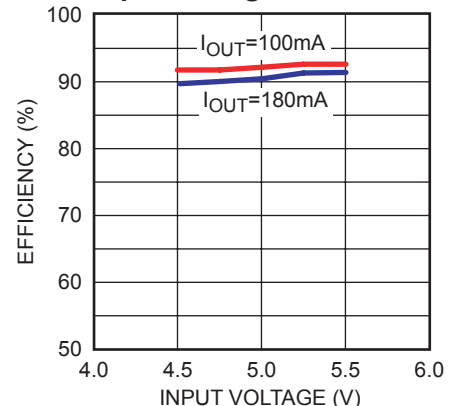

PACKAGE REFERENCE

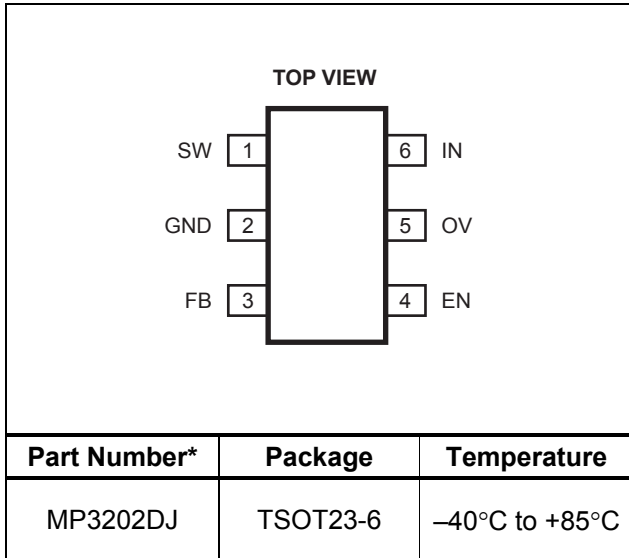

* For Tape & Reel, add suffix -Z (eg. MP3202DJ-Z)
 For RoHS compliant packaging, add suffix -LF
 (eg. MP3202DJ-LF-Z)

ABSOLUTE MAXIMUM RATINGS ⁽¹⁾

SW Pin.....-0.5V to +28.5V
 All Other Pins.....-0.3V to +6.5V
 Storage Temperature..... -55°C to +150°C

Recommended Operating Conditions ⁽²⁾

IN Supply Voltage2.5V to 6V
 Output Voltage V_{IN} to 25V
 Operating Temperature..... -40°C to +85°C

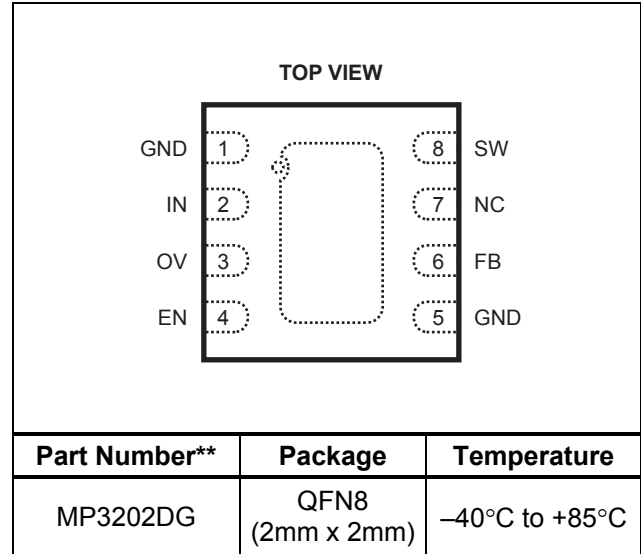

** For Tape & Reel, add suffix -Z (eg. MP3202DG-Z)
 For RoHS compliant packaging, add suffix -LF
 (eg. MP3202DG-LF-Z)

Thermal Resistance ⁽³⁾ θ_{JA} θ_{JC}
 TSOT23-6..... 220 110.. °C/W
 QFN8 (2mm x 2mm)..... 80 16... °C/W

Notes:

- 1) Exceeding these ratings may damage the device.
- 2) The device is not guaranteed to function outside of its operating conditions.
- 3) Measured on approximately 1" square of 1 oz copper.

ELECTRICAL CHARACTERISTICS

$V_{IN} = V_{EN} = 5V$, $T_A = +25^\circ C$, unless otherwise noted.

| Parameters | Symbol | Condition | Min | Typ | Max | Units |
|----------------------------------|----------|------------------|-----|------|------|---------|
| Operating Input Voltage | V_{IN} | | 2.5 | | 6 | V |
| Supply Current (Shutdown) | | $V_{EN} = 0V$ | | 0.1 | 1 | μA |
| Supply Current (Quiescent) | | $V_{FB} = 0.15V$ | | 690 | 750 | μA |
| Switching Frequency | f_{SW} | | 1.0 | 1.3 | 1.5 | MHz |
| Maximum Duty Cycle | | $V_{FB} = 0V$ | 85 | 92 | | % |
| Under Voltage Lockout | | | | | | |
| IN Under Voltage Lockout | UVLO | V_{IN} Rising | | 2.25 | 2.45 | V |
| Under Voltage Lockout Hysteresis | | | | 92 | | mV |
| Open Lamp Shutdown Threshold | V_{OV} | V_{OV} Rising | | 28 | | V |

ELECTRICAL CHARACTERISTICS *(continued)* $V_{IN} = V_{EN} = 5V$, $T_A = +25^{\circ}C$, unless otherwise noted.

| Parameters | Symbol | Condition | Min | Typ | Max | Units |
|---------------------------------|----------|----------------------------------|------|------|-----|-------------|
| Enable | | | | | | |
| EN Threshold | | V_{EN} Rising, $V_{IN} = 5V$ | 1.0 | 1.35 | 1.6 | V |
| EN Threshold | | V_{EN} Rising, $V_{IN} = 2.5V$ | 0.8 | | | V |
| EN Hysteresis | | | | 90 | | mV |
| EN Input Bias Current | | $V_{EN} = 0V, 5V$ | | | 1 | μA |
| Feedback | | | | | | |
| FB Voltage | | | 94 | 104 | 114 | mV |
| FB Input Bias Current | | $V_{FB} = 0.1V$ | -600 | -300 | | nA |
| Output Switch | | | | | | |
| SW On-Resistance ⁽⁴⁾ | R_{ON} | | | 0.5 | | Ω |
| SW Current Limit ⁽⁴⁾ | | Duty Cycle = 60% | | 1.33 | | A |
| Thermal Shutdown ⁽⁴⁾ | | | | 160 | | $^{\circ}C$ |

Notes:

4) Guaranteed by design.

PIN FUNCTIONS

| TSOT23-6 Pin # | QFN8 Pin # | Name | Description |
|----------------|------------|------|--|
| 1 | 8 | SW | Power Switch Output. SW is the drain of the internal MOSFET switch. Connect the power inductor and output rectifier to SW. SW can swing between GND and 25V. |
| 2 | 1, 5 | GND | Ground. |
| 3 | 6 | FB | Feedback Input. The MP3202 regulates the voltage across the current sense resistor between FB and GND. Connect a current sense resistor from the bottom of the LED string to GND. Connect the bottom of the LED string to FB. The regulation voltage is 104mV. |
| 4 | 4 | EN | Regulator On/Off Control Input. A high input at EN turns on the converter, and a low input turns it off. When not used, connect EN to the input source for automatic startup. The EN pin cannot be left floating. |
| 5 | 3 | OV | Over Voltage Input. OV measures the output voltage for open circuit protection. Connect OV to the output at the top of the LED string. |
| 6 | 2 | IN | Input Supply Pin. Must be locally bypassed. |
| | 7 | NC | No Connect. |

OPERATION

The MP3202 uses a constant frequency, peak current mode boost regulator architecture to regulate the strings of white LEDs. Refer to the block diagram in Figure 1 for details.

At the start of each oscillator cycle the FET is turned on through the control circuitry. To prevent sub-harmonic oscillations at duty cycles greater than 50%, a stabilizing ramp is added to the output of the current sense amplifier and the result is fed into the positive input of the PWM comparator. When this voltage equals the output voltage of the error amplifier the power FET is turned off.

The voltage at the output of the error amplifier is an amplified version of the difference between the 104mV reference voltage and the feedback voltage. In this way the peak current level keeps the output in regulation.

If the feedback voltage starts to drop, the output of the error amplifier increases. This results in more current flowing through the power FET, thus increasing the power delivered to the output.

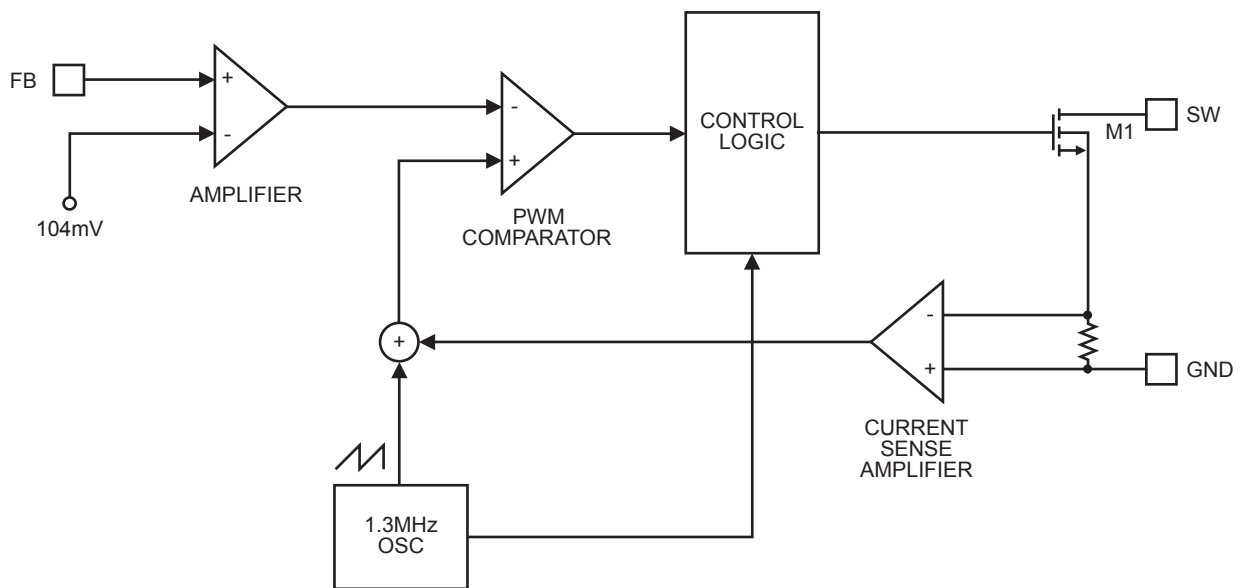

Figure 1—Functional Block Diagram

APPLICATION INFORMATION

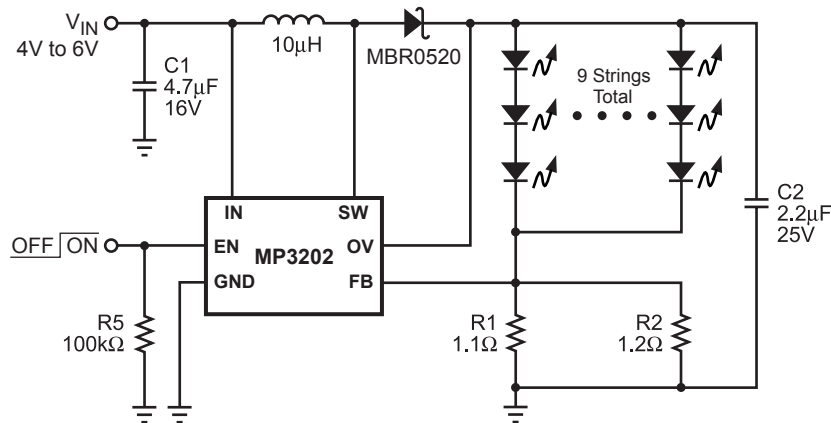

Figure 2—Circuit for Driving 27 WLEDs

A typical application circuit is provided in Figure 2. The 27 white LEDs can be driven from a voltage supply range of 4V to 6V at a total output current of 180mA. A 2.2µF output capacitor is sufficient for most applications but up to 1µF may be used. A 10µH inductor with low DCR (inductor resistance) is recommended to improve efficiency. A 4.7µF ceramic capacitor is recommended for the input capacitance in the real system. Schottky diodes with fast recovery and a low forward voltage are recommended. Schottky diodes with a 500mA rating are sufficient for the MP3202. The switching characteristics during normal operation can be seen in Figure 3. The MP3202 has internal soft-start to limit the amount of current through the IN pin at startup and to also limit the amount of overshoot on the output. The current limit is increased by a fourth every 40µs giving a total soft-start time of 120µs.

Steady State Operation

$V_{IN} = 5V$, 27 LEDs, 180mA

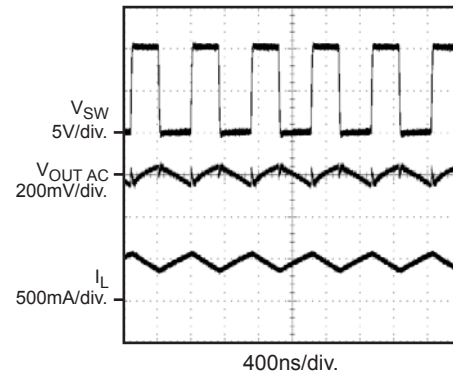

Figure 3—Steady State Operation

Figure 4 shows the startup behavior of the MP3202. The ramped voltage added to the current sense amplifier reduces the current output as the duty cycle increases. As more LEDs are added, the output voltage rises but the current that can be delivered to the load is reduced as well.



Figure 4—Startup Waveforms

Figure 5 shows the dependence on current limit versus duty cycle.



Figure 5—Current Limit vs. Duty Cycle

Setting the LED Current

The LED current is controlled by the feedback resistors R1 and R2, as shown in Figure 2. The current through the LEDs is given by the equation:

$$I_{LED} = 104\text{mV} \times \frac{R1 + R2}{R1 \times R2}$$

Table 1 shows the selection of resistors for a given LED current.

Table 1— I_{LED} vs. R1

| I_{LED} (mA) | R1 (Ω) | R2 (Ω) |
|----------------|-----------------|-----------------|
| 10 | 10.4 | N/A |
| 50 | 2.08 | N/A |
| 100 | 1.04 | N/A |
| 150 | 1.5 | 1.3 |
| 180 | 1.2 | 1.1 |

Analog and Digital Dimming

There are three methods to control dimming for the MP3202 during normal operation. The first method uses DC voltage to control the feedback voltage. This is shown in Figure 6. As the DC voltage increases, current starts flowing down R1, R2 and R3. The loop will continue to regulate the feedback voltage to 104mV. Thus the current has to decrease through the LEDs by the same amount of current as is being injected from the DC voltage source. With a V_{DC} from 0V to 2V, the resistor values shown for R2 and R3 can control the LED current from 0mA to 20mA.



Figure 6—Dimming Control Using a DC Voltage

Other applications require a logic signal to control dimming. This is shown in Figure 7. The PWM signal is applied to the EN pin of the MP3202. The LEDs will switch between full load to completely shut off. The average current through the LEDs will increase proportionally to the duty cycle of the PWM signal. The PWM signal used in Figure 7 should be 1KHz or below due to the soft-start function.



Figure 7—PWM Dimming Control Using a Logic Signal

If the PWM signal is above 1KHz, dimming can be achieved using the circuit shown in Figure 8.



Figure 8— Dimming Control Using a Filtered PWM Signal

Open Load Protection

Open Load protection will shut off the MP3202 if the output voltage rises too high when the OV pin is tied to the output. In some cases an LED may fail. This will result in the feedback voltage always remaining at zero.

The part will run at maximum duty cycle boosting the output voltage higher and higher. By tying the OV pin to the top of the LED string the MP3202 can check for this condition. If the output exceeds 28V, the MP3202 will shut down. The part will not switch again until the power is recycled. Figure 9 shows the behavior of the MP3202 into an open load.

Startup Waveforms into an Open Load

$V_{IN} = 3.6V$

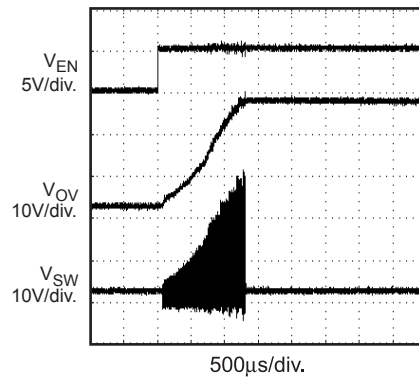

Figure 9—Startup Waveforms into an Open Load

Layout Considerations

Careful attention must be paid to the PCB board layout and component placement. Proper layout of the high frequency switching path is critical to prevent noise and electromagnetic interference problems. Due to high frequency switching, the length and area of all the traces connected to the switch node should be minimized.

PACKAGE INFORMATION

TSOT23-6

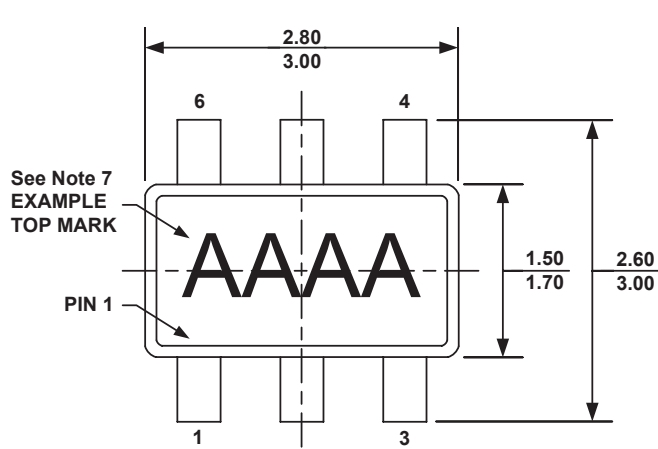

TOP VIEW

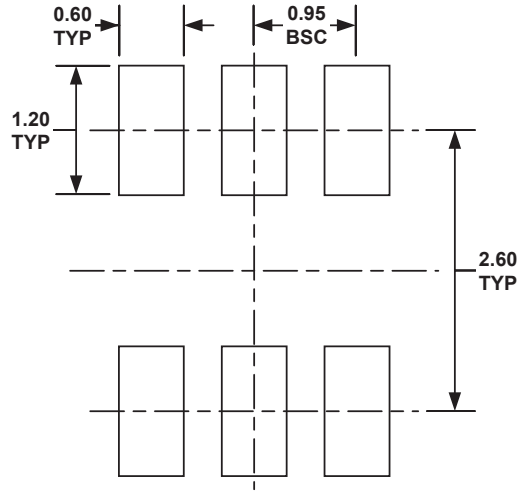

RECOMMENDED LAND PATTERN

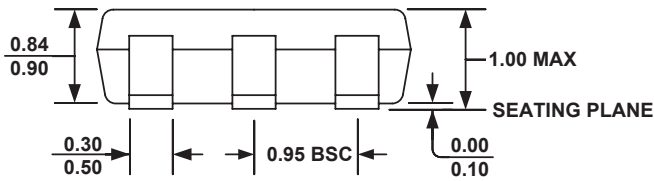

FRONT VIEW

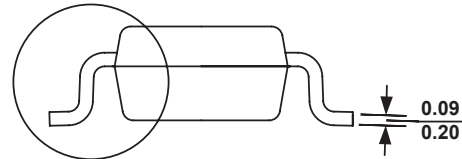

SIDE VIEW

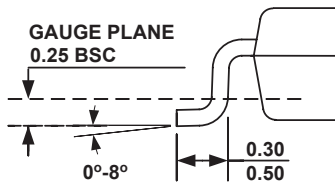

DETAIL A

NOTE:

- 1) ALL DIMENSIONS ARE IN MILLIMETERS.
- 2) PACKAGE LENGTH DOES NOT INCLUDE MOLD FLASH, PROTRUSION OR GATE BURR.
- 3) PACKAGE WIDTH DOES NOT INCLUDE INTERLEAD FLASH OR PROTRUSION.
- 4) LEAD COPLANARITY (BOTTOM OF LEADS AFTER FORMING) SHALL BE 0.10 MILLIMETERS MAX.
- 5) DRAWING CONFORMS TO JEDEC MO-193, VARIATION AB.
- 6) DRAWING IS NOT TO SCALE.
- 7) PIN 1 IS LOWER LEFT PIN WHEN READING TOP MARK FROM LEFT TO RIGHT, (SEE EXAMPLE TOP MARK)

QFN8 (2mm x 2mm)

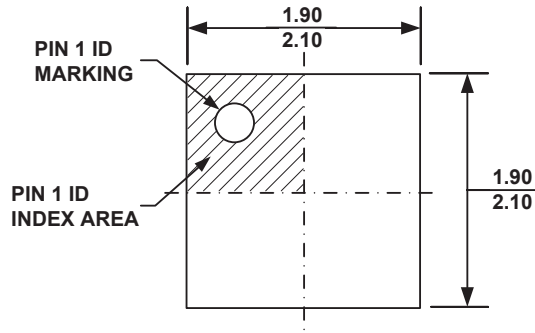

TOP VIEW

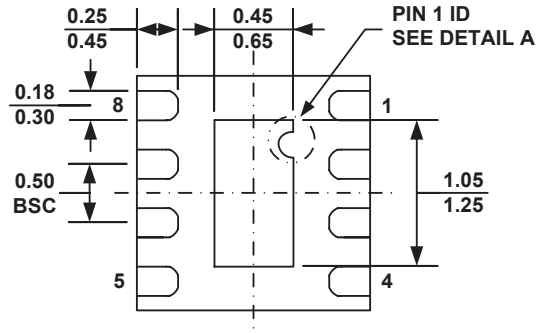

BOTTOM VIEW

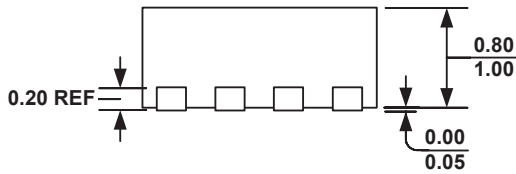

SIDE VIEW

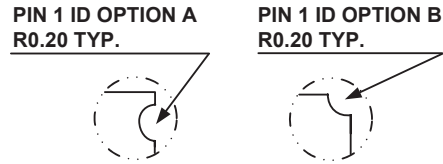

DETAIL A

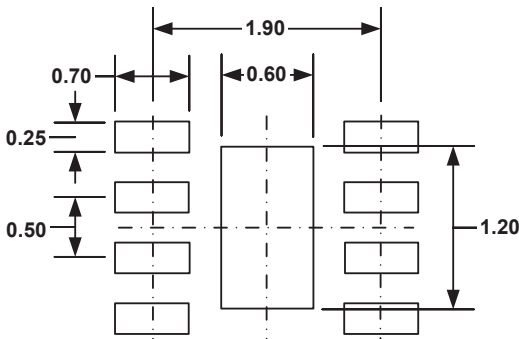

RECOMMENDED LAND PATTERN

NOTE:

- 1) ALL DIMENSIONS ARE IN MILLIMETERS.
- 2) EXPOSED PADDLE SIZE DOES NOT INCLUDE MOLD FLASH.
- 3) LEAD COPLANARITY SHALL BE 0.10 MILLIMETER MAX.
- 4) DRAWING CONFORMS TO JEDEC MO-229, VARIATION VCCD-3.
- 5) DRAWING IS NOT TO SCALE.

NOTICE: The information in this document is subject to change without notice. Users should warrant and guarantee that third party Intellectual Property rights are not infringed upon when integrating MPS products into any application. MPS will not assume any legal responsibility for any said applications.