

SCL3300

Data Sheet

SCL3300-D01 3-axis inclinometer with angle output and digital SPI interface

Features

- 3-axis (XYZ) inclinometer
- User selectable measurement modes:
 - 3000 LSB/g with 70 Hz LPF
 - 6000 LSB/g with 40 Hz LPF
 - 12000 LSB/g with 10 Hz LPF
- Angle output resolution 0.0055°/LSB
- -40°C...+125°C operating range
- 3.0V...3.6V supply voltage
- SPI digital interface
- Ultra-low 0.001 °/√Hz noise density
- Excellent offset stability
- Size 8.6 x 7.6 x 3.3 mm (l x w x h)
- Proven capacitive 3D-MEMS technology

Applications

SCL3300-D01 is targeted at applications demanding high stability and accuracy with tough environmental requirements.

Typical applications include:

- Leveling
- Tilt sensing
- Machine control
- Structural health monitoring
- Inertial measurement units (IMUs)
- Robotics
- Positioning and guidance systems

Overview

The SCL3300-D01 is a high-performance inclinometer sensor. It is a three-axis inclinometer sensor with angle output based on Murata's proven capacitive 3D-MEMS technology. Signal processing is done in a mixed-signal ASIC with flexible SPI digital interface. Sensor element and ASIC are packaged into a 12-pin pre-molded plastic housing that guarantees reliable operation over the product's lifetime.

The SCL3300-D01 is designed, manufactured and tested for high stability, reliability and quality requirements. The component has extremely stable output over a wide range of temperature and vibration. The component has several advanced self-diagnostics features, is suitable for SMD mounting, and is compatible with the RoHS and ELV directives.

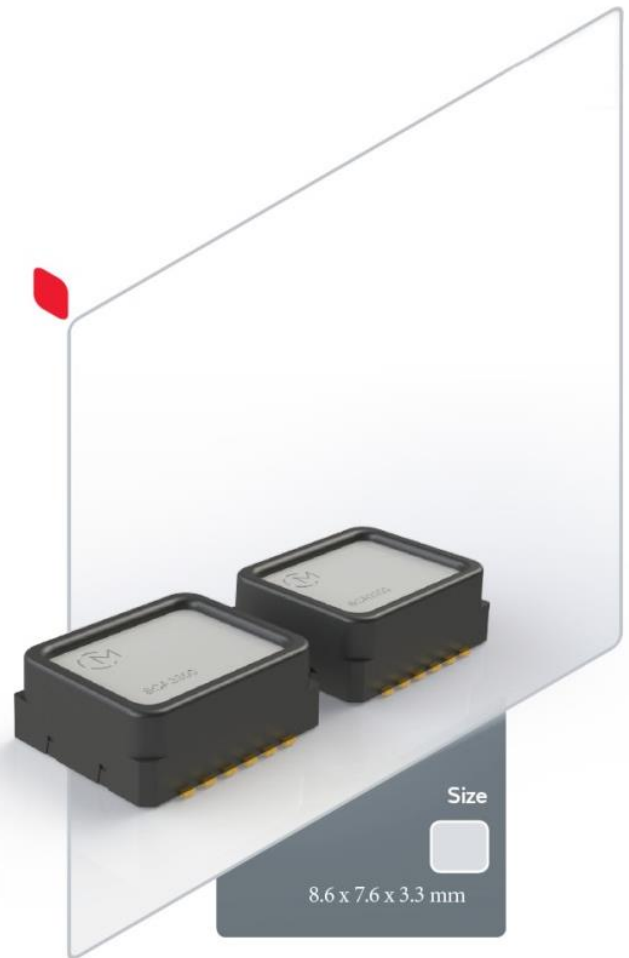

TABLE OF CONTENTS

1	Introduction	4
2	Specifications	4
2.1	Abbreviations	4
2.2	General Specifications	4
2.3	Performance Specifications for Inclinometer	5
2.4	Performance Specification for Temperature Sensor.....	7
2.5	Specification for Angle Outputs.....	7
2.6	Absolute Maximum Ratings	8
2.7	AEC-Q100 Testing.....	8
2.8	Pin Description.....	9
2.9	Typical performance characteristics.....	10
2.10	Digital I/O Specification.....	13
2.10.1	SPI DC Characteristics	13
2.10.2	SPI AC Characteristics	14
2.11	Measurement Axis and Directions.....	15
2.11.1	Measurement Ranges on Inclination Modes	16
2.12	Package Characteristics	17
2.12.1	Package Outline Drawing	17
2.13	PCB Footprint	18
3	General Product Description	19
3.1	Factory Calibration.....	19
4	Component Operation, Reset and Power Up	20
4.1	Component Operation.....	20
4.2	Start-up sequence	21
4.3	Operation modes	22
5	Component Interfacing	22
5.1.1	General.....	22
5.1.2	Protocol	23
5.1.3	SPI frame	24
5.1.4	Operations.....	25
5.1.5	Return Status.....	26
5.2	Checksum (CRC).....	26
6	Register Definition	27
6.1	Sensor Data Block	29
6.1.1	Example of Acceleration Data Conversion	30

6.1.2	Example of Temperature Data Conversion	31
6.1.3	Example of Angle Data Conversion	32
6.2	STO	33
6.2.1	Example of Self-Test Analysis	35
6.3	STATUS	36
6.3.1	Example of STATUS summary reset	38
6.4	Error Flag Block	39
6.4.1	ERR_FLAG1	39
6.4.2	ERR_FLAG2	40
6.5	CMD	41
6.6	ANG_CTRL	42
6.7	WHOAMI	42
6.8	Serial Block	43
6.8.1	Example of Resolving Serial Number	44
6.9	SELBANK	45
7	Application information	45
7.1	Application Circuitry and External Component Characteristics	45
7.2	Assembly Instructions	47
8	Traceability	47
9	Frequently Asked Questions	47
10	Order Information	48

1 Introduction

This document contains essential technical information about the SCL3300-D01 sensor including specifications, SPI interface descriptions, user accessible register details, electrical properties and application information. This document should be used as a reference when designing the SCL3300-D01 component into a system.

2 Specifications

2.1 Abbreviations

ASIC	Application Specific Integrated Circuit
SPI	Serial Peripheral Interface
RT	Room Temperature, +23 °C
FS	Full Scale
CSB	Chip Select
SCK	Serial Clock
MOSI	Master Out Slave In
MISO	Master In Slave Out
MCU	Microcontroller
STO	Self-test Output

2.2 General Specifications

General specifications for the SCL3300-D01 component are presented in Table 1. All analog voltages are referenced to the potential at AVSS, and all digital voltages are referenced to the potential at DVSS.

Table 1 General specifications

Parameter	Condition	Min	Nom	Max	Units
Supply voltage: VDD		3.0	3.3	3.6	V
SPI supply voltage: DVIO	Must never be higher than VDD	3.0	3.3	3.6	V
Current consumption: I _{VDD}	Temperature range -40 ... +125 °C Standard operation		1.2		mA
	Mode 4		2.1		
Current consumption: I _{VDD} in power down mode	Temperature range -40 ... +125 °C Power down mode (PD) Typical value is at room temperature (+23°C)		3	10	μA

2.3 Performance Specifications for Inclinometer

Table 2 Inclinometer performance specifications. Supply voltage VDD = 3.3 V and room temperature (RT) +23 °C unless otherwise specified. Definition of gravitational acceleration: $g = 9.819 \text{ m/s}^2$.

Parameter	Condition	Min	Nom	Max	Unit
Measurement range	Mode 1 Mode 2 Mode 3, Mode 4 ^(A)		1.2 2.4 -		g
	Mode 1 Mode 2 Mode 3, Mode 4 ^(A)		±90 ±90 (±10)		°
Offset error ^(B)	All modes, X, Z channels	-20 -1.15		20 1.15	mg °
	All modes, Y channel	-25 -1.45		20 1.15	mg °
Offset temperature dependency ^(C)	-40°C ... +125°C, X, Y channels	-10 -0.57		10 0.57	mg °
	-40°C ... +125°C, Z channel	-15 -0.86		15 0.86	mg °
Offset lifetime drift ^(D)	All modes, X, Z channels	-8 -0.46	±4 ±0.23	8 0.46	mg °
	All modes, Y channels	-12 -0.69	±6 ±0.34	12 0.69	mg °
Sensitivity (acceleration output)	Mode 1 Mode 2 Mode 3, Mode 4		6000 3000 12000		LSB/g
	Mode 1 Mode 2 Mode 3, Mode 4 valid only between 0...1° ^(E)		105 52 209		LSB/°
Sensitivity (inclination output)	All modes		182		LSB/°
Sensitivity error ^(B)	-40°C ... +125°C Mode 1	-0.7		0.7	%
Sensitivity temperature dependency ^(C)	-40°C ... +125°C Mode 1	-0.3		0.3	%
Linearity error ^(F)	-1g ... +1g range	-4		4	mg
Integrated noise (RMS, accelerometer) ^(G)	Mode 1, all channels			0.32	mg _{RMS}
	Mode 2, all channels			0.49	
	Mode 3, all channels			0.13	
	Mode 4, X, Z channels			0.08	
	Mode 4, Y channel			0.06	
Noise density ^(G)	Mode 1, all channels			41	µg/√Hz
	Mode 2, all channels			47	
	Mode 3, all channels			32	
	Mode 4, X, Z channels			20	
	Mode 4, Y channel			15	
Noise density ^(G)	Mode 1, all channels			0.0024	°/√Hz
	Mode 2, all channels			0.0027	
	Mode 3, all channels			0.0018	
	Mode 4, X, Z channels			0.0012	
	Mode 4, Y channel			0.0009	
Cross axis sensitivity ^(H)	per axis	-1.5	±0.2	1.5	%

Parameter	Condition	Min	Nom	Max	Unit
Amplitude response, -3dB frequency	Mode 1		40		Hz
	Mode 2		70		Hz
	Mode 3, Mode 4		10		Hz
Power on start-up time ^l	Mode 1		25		ms
	Mode 2		15		ms
	Mode 3, Mode 4		100		ms
ODR			2000		Hz

Min/Max values are ± 3 sigma variation limits from test population at the minimum. Min/Max values are not guaranteed.

- A) Inclination mode. Dynamic range is dependent on orientation in gravity. See Chapter 2.11.1
- B) Includes calibration error, temperature, supply voltage and drift over lifetime.
- C) Deviation from value at room temperature (RT).
- D) Min/Max results based on the maximum ± 3 sigma variation limits of the following tests:
 HTOL bake (+125 °C, 1000h), TC (-50 °C / +150 °C, 1000 cycles), THB (85 °C / 85 %RH).
- E) Angle calculated using $1g * \sin(\theta)$, where θ is the inclination angle relative to the 0g position. Due to characteristics of sine function sensitivity is inversely proportional to inclination angle. Reported values are valid only between 0° to $\pm 1^\circ$.
- F) Straight line through specified measurement range end points.
- G) SPI communication may affect the noise level. Used SPI clock should be carefully validated. Recommended SPI clock is 2 MHz - 4 MHz to achieve the best performance; see section 2.10.2 SPI AC Characteristics for details.
- H) Cross axis sensitivity is the maximum sensitivity in the plane perpendicular to the measuring direction. X-axis output cross axis sensitivity (cross axis for Y and Z-axis outputs are defined correspondingly):
- Cross axis for Y axis = Sensitivity Y / Sensitivity X
 - Cross axis for Z axis = Sensitivity Z / Sensitivity X
- I) Power on start-up time is specified according to recommended start-up sequence; see section 4.2 Start-up sequence for details.

2.4 Performance Specification for Temperature Sensor

Table 3 Temperature sensor performance specifications.

Parameter	Condition	Min.	Typ	Max.	Unit
Temperature signal range		-50		+150	°C
Temperature signal sensitivity	Direct 16-bit word		18.9		LSB/°C
Temperature signal offset	°C output	-10		10	°C

Temperature is converted to °C with following equation:

$$\text{Temperature } [^{\circ}\text{C}] = -273 + (\text{TEMP} / 18.9),$$

where TEMP is temperature sensor output register content in decimal format.

2.5 Specification for Angle Outputs

Angles are formed from acceleration with following equations:

$$\begin{aligned} \text{ANG_X} &= \text{atan2}(\text{accx} / \sqrt{\text{accy}^2 + \text{accz}^2}), \\ \text{ANG_Y} &= \text{atan2}(\text{accy} / \sqrt{\text{accx}^2 + \text{accz}^2}), \\ \text{ANG_Z} &= \text{atan2}(\text{accz} / \sqrt{\text{accx}^2 + \text{accy}^2}), \end{aligned}$$

where accx, accy, and accz are accelerations to each direction and ANG_X, ANG_Y, and ANG_Z are angle output register content in 16-bit binary format.

Angles are converted to degrees with following equation:

$$\text{Angle } [^{\circ}] = \text{d'ANG_} \% / 2^{14} * 90,$$

where d'ANG_% is angle output register (ANG_X, ANG_Y, ANG_Z) content in decimal format. See 6.1.3 Example of Angle Data Conversion for more information.

2.6 Absolute Maximum Ratings

Within the maximum ratings (Table 4), no damage to the component shall occur. Parametric values may deviate from specification, yet no functional failure shall occur.

Table 4. Absolute maximum ratings.

Symbol	Description	Min.	Typ	Max.	Unit
VDD	Supply voltage analog circuitry	-0.3		4.3	V
DVIO	Supply voltage SPI	-0.3		4.3	V
DIN/DOUT	Maximum voltage at digital input and output pins	-0.3		DVIO+0.3	V
Topr	Operating temperature range	-40		+125	°C
Tstg	Storage temperature range	-40		+150	°C
ESD_HBM	ESD according Human Body Model (HBM) Q100-002	-2000		2000	V
ESD_CDM	ESD according Charged Device Model (CDM) Q100-011	-1000		1000	V
US	Ultrasonic agitation (cleaning, welding, etc.)	Prohibited			

2.7 AEC-Q100 Testing

The SCL3300 product family is tested according to AEC-Q100 Grade 1, revision H. Deviations to the requirements are presented in Table 5.

Table 5. Deviations to AEC-Q100 requirements.

Stress	ABV	Requirement	Deviation
Package Drop	DR0P	Drop part on each of 6 axes once from a height of 1.2m onto a concrete surface.	10 Drops, random orientation, drop height 0.8m ¹

¹ Shocks may cause mechanical damage to the internal structures of MEMS sensor, causing malfunction of sensor, therefore mechanical shocks should be avoided. The level depends heavily on the pulse width and shape and should be evaluated case by case. As a general guideline, the lighter assembly or part, the higher shock levels will be generated on sensor component. **Dropped components shall not be used and shall be scrapped.**

2.8 Pin Description

The pinout for SCL3300-D01 is presented in Figure 1.

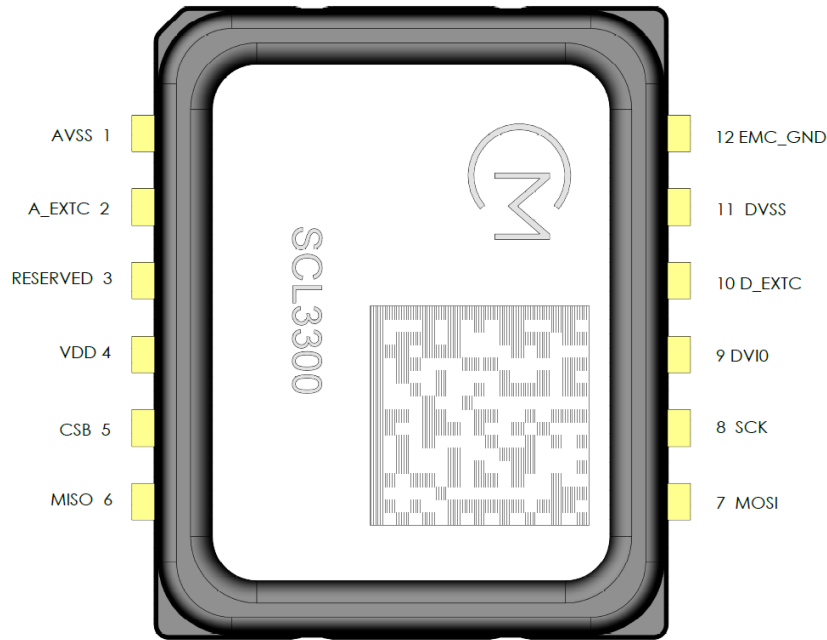

Figure 1 Pinout for SCL3300-D01.

Table 6 SCL3300-D01 pin descriptions.

Pin#	Name	Type	Description
1	AVSS	GND	Analog Reference Ground, connect externally to GND
2	A_EXTC	AOUT	External capacitor connection for analog core
3	RESERVED	-	Factory use only, connect externally to GND
4	VDD	SUPPLY	Analog Supply Voltage
5	CSB	DIN	Chip Select of SPI Interface, 3.3V logic compatible Schmitt-trigger input
6	MISO	DOOUT	Data Out of SPI Interface
7	MOSI	DIN	Data In of SPI Interface, 3.3V logic compatible Schmitt-trigger input
8	SCK	DIN	CLK Signal of SPI Interface, 3.3V logic compatible Schmitt-trigger input
9	DVIO	SUPPLY	SPI Interface Supply Voltage. Must never be higher than VDD
10	D_EXTC	AOUT	External capacitor connection for digital core
11	DVSS	GND	Digital Reference Ground, connect externally to GND. Must never be left floating when component is powered.
12	EMC_GND	EMC GND	EMC Ground, connect externally to GND

2.9 Typical performance characteristics

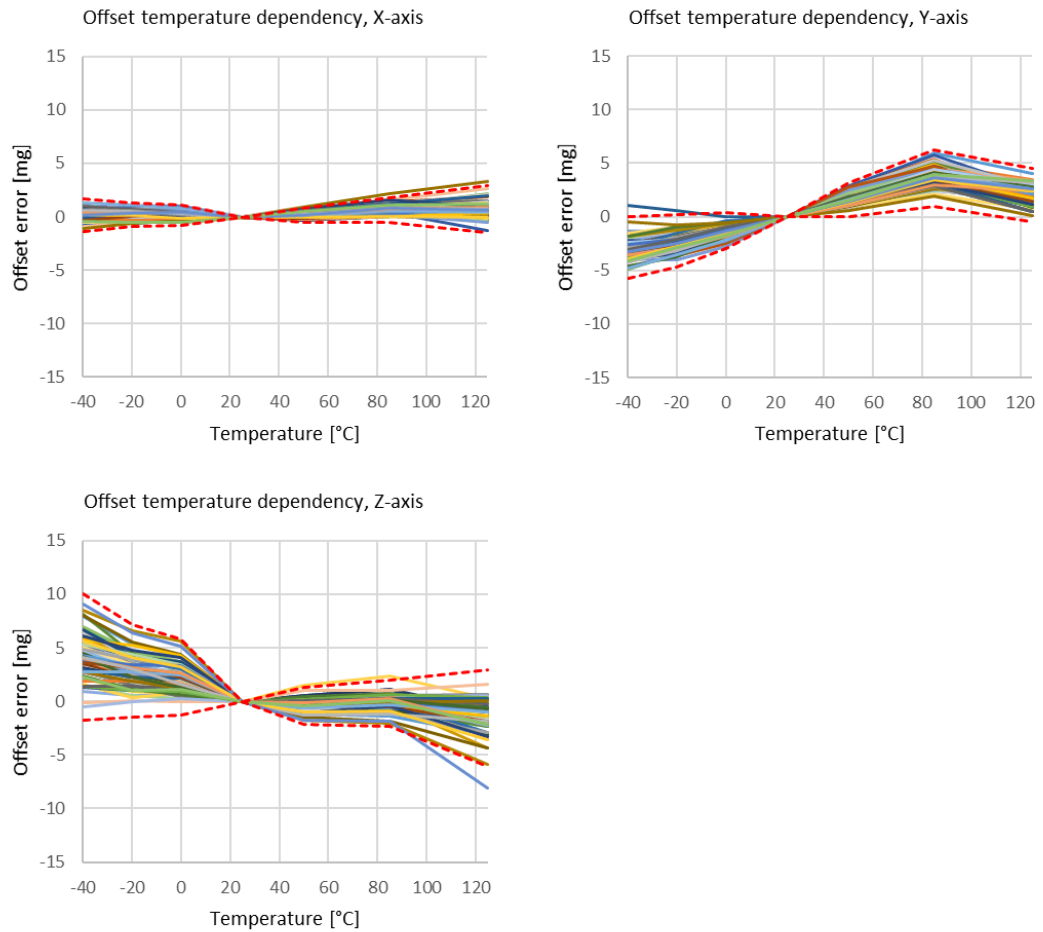

Figure 2 Accelerometer typical offset temperature behavior. Dotted lines show the $\pm 3\sigma$ variation of the population.

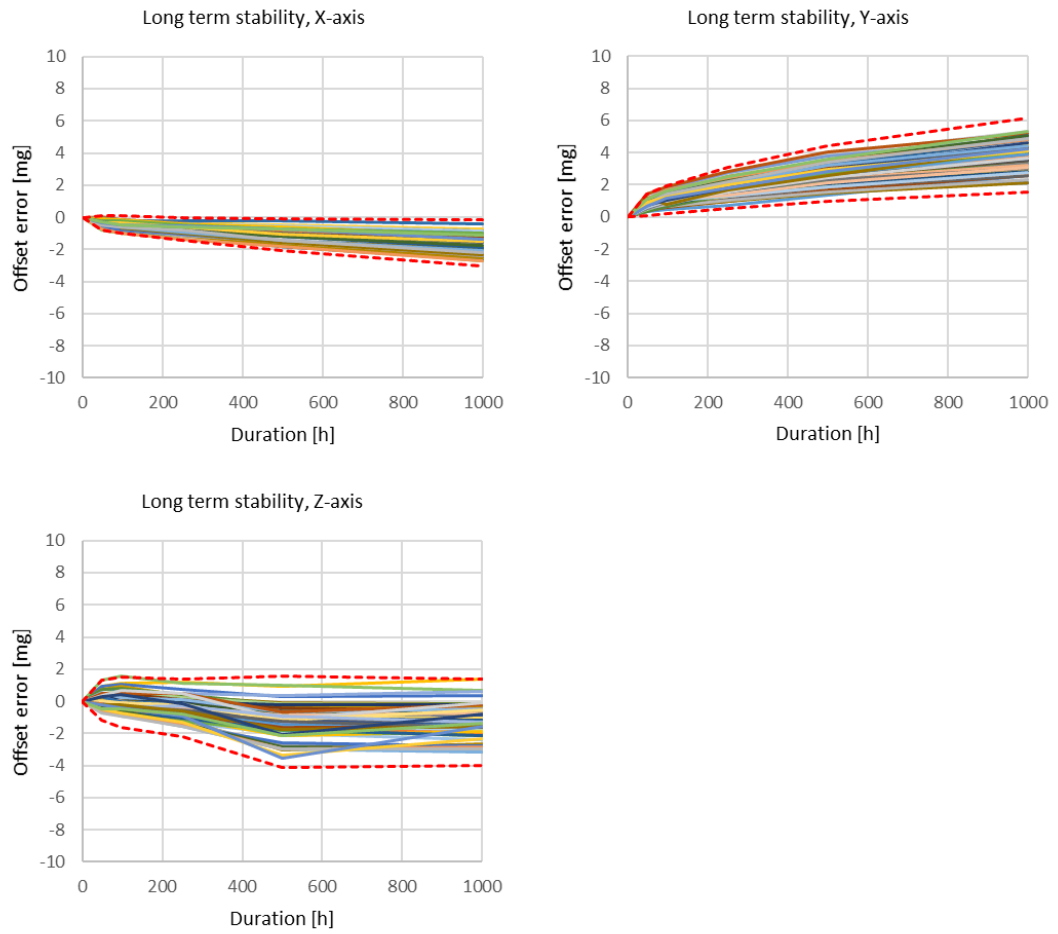

Figure 3 Example of accelerometer long term stability during 1000h HTOL. Test condition = +85 °C, Vsupply=3.6 V. Data measurement condition = +25 °C. Dotted lines show the $\pm 3\sigma$ variation of the population.

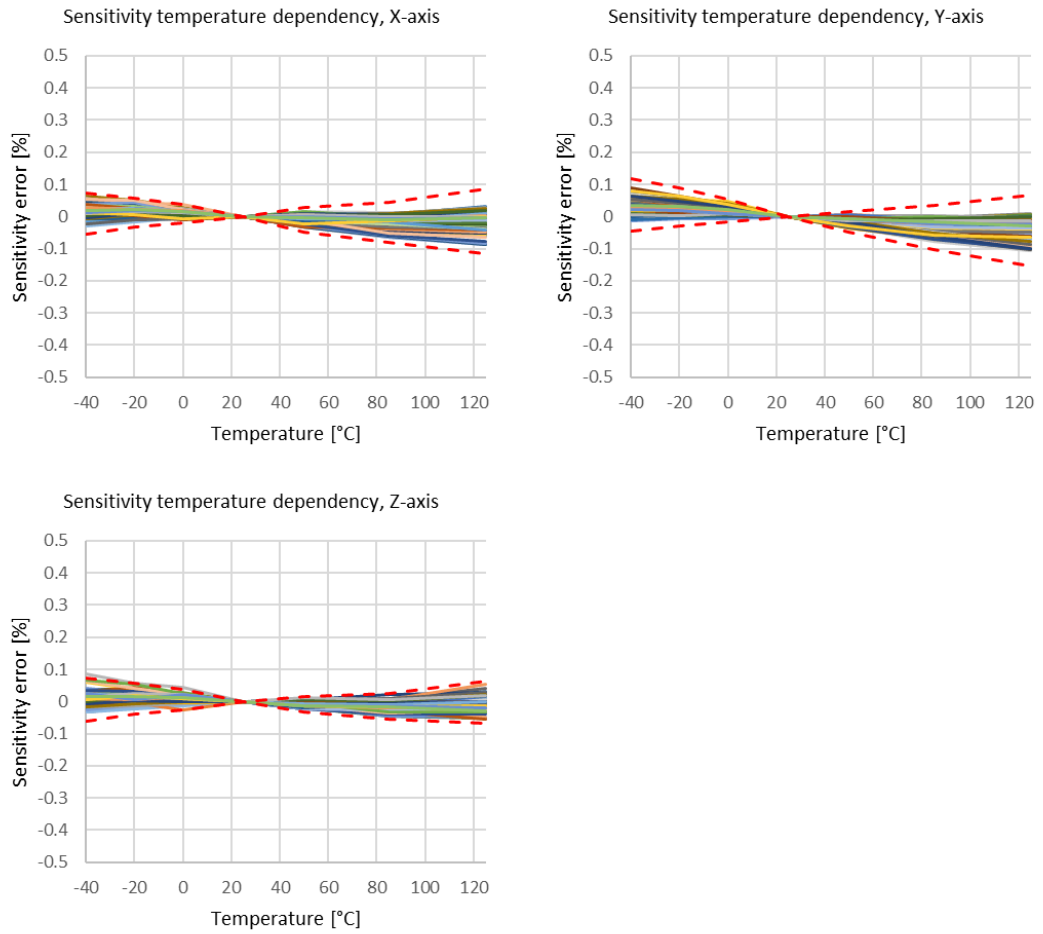

Figure 4 Accelerometer typical sensitivity temperature error in %

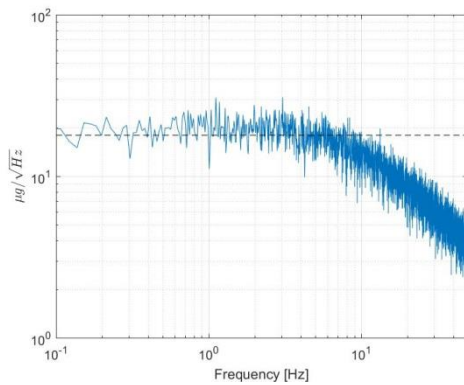

Figure 5 Example noise spectrum of X-channel in mode 4

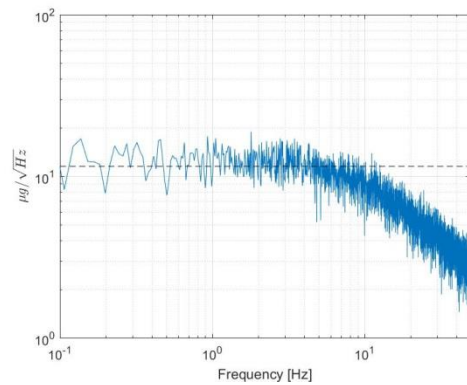

Figure 6 Example noise spectrum of Y-channel in mode 4

2.10 Digital I/O Specification

2.10.1 SPI DC Characteristics

Table 7 describes the DC characteristics of SCL3300-D01 sensor SPI I/O pins. Supply voltage is 3.3 V unless otherwise specified. Current flowing into the circuit has a positive value.

Table 7 SPI DC Characteristics

Symbol	Remark	Min.	Typ	Max.	Unit	
Serial Clock SCK (Pull Down)						
I_{PD}	Pull-down current	$V_{in} = 3.0 - 3.6 V$	7.5	16.5	36	μA
V_{IH}	Input voltage '1'	$0.67 \cdot DVIO$		DVIO	V	
V_{IL}	Input voltage '0'	0		$0.33 \cdot DVIO$	V	
Chip Select CSB (Pull Up), low active						
I_{PU}	Pull-up current	$V_{in} = 0$	7.5	16.5	36	μA
V_{IH}	Input voltage '1'	$0.67 \cdot DVIO$		DVIO	V	
V_{IL}	Input voltage '0'	0		$0.33 \cdot DVIO$	V	
Serial Data Input MOSI (Pull Down)						
I_{PD}	Pull-down current	$V_{in} = 3.0 - 3.6 V$	7.5	16.5	36	μA
V_{IH}	Input voltage '1'	$0.67 \cdot DVIO$		DVIO	V	
V_{IL}	Input voltage '0'	0		$0.33 \cdot DVIO$	V	
Serial Data Output MISO (Tri State)						
V_{OH}	Output high voltage	$I > -1 mA$	$DVIO - 0.5V$			V
V_{OL}	Output low voltage	$I < 1 mA$			0.5	V
I_{LEAK}	Tri-state leakage	$0 < V_{MISO} < 3.3 V$	-1	0	1	μA
	Maximum Capacitive load				50	pF

2.10.2 SPI AC Characteristics

The AC characteristics of SCL3300-D01 are defined in Figure 7 and Table 8.

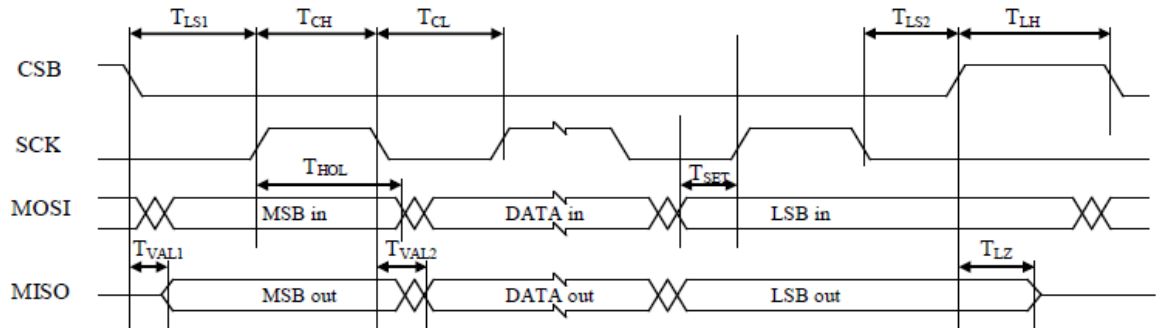

Figure 7 Timing diagram of SPI communication.

Table 8 SPI AC electrical characteristics.

Symbol	Description	Min.	Typ	Max.	Unit
T_{LS1}	Time from CSB (10%) to SCK (90%)	63			ns
T_{LS2}	Time from SCK (10%) to CSB (90%)	63			ns
T_{CL}	SCK low time	25			ns
T_{CH}	SCK high time	25			ns
$f_{SCK} = 1/T_{per}$	SCK Frequency *	0.1	2	8	MHz
T_{SET}	Time from changing MOSI (10%, 90%) to SCK (90%). Data setup time	32			ns
T_{HOL}	Time from SCK (90%) to changing MOSI (10%, 90%). Data hold time	32			ns
T_{VAL1}	Time from CSB (10%) to stable MISO (10%, 90%)	4	10	16	ns
T_{LZ}	Time from CSB (90%) to high impedance state of MISO		10		ns
T_{VAL2}	Time from SCK (10%) to stable MISO (10%, 90%)	4	10	16	ns
T_{LH}	Time between SPI cycles, CSB at high level (90%)	10			us

* SPI communication may affect the noise level. Used SPI clock should be carefully validated. Recommended SPI clock is 2 MHz - 4 MHz to achieve the best performance.

2.11 Measurement Axis and Directions

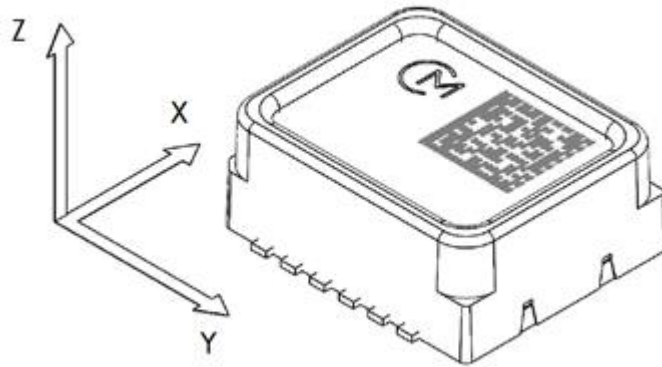







Figure 8 SCL3300-D01 measurement directions.

Table 9 SCL3300-D01 accelerometer measurement directions.

 <p>x: +1g angle x: 90° y: 0g angle y: 0° z: 0g angle z: 0°</p>	 <p>x: 0g angle x: 0° y: +1g angle y: 90° z: 0g angle z: 0°</p>	 <p>x: 0g angle x: 0° y: 0g angle y: 0° z: +1g angle z: 90°</p>
 <p>x: -1g angle x: 270° y: 0g angle y: 0° z: 0g angle z: 0°</p>	 <p>x: 0g angle x: 0° y: -1g angle y: 270° z: 0g angle z: 0°</p>	 <p>x: 0g angle x: 0° y: 0g angle y: 0° z: -1g angle z: 270°</p>

2.11.1 Measurement Ranges on Inclination Modes

Inclination ranges are limited in Mode 3 and Mode 4 to maximum $\pm 10^\circ$ inclination. See Figure 9 Measurement ranges on inclination modes (Mode 3 and Mode 4) below. If the whole 360° operation is needed, then one should select either Mode 1 or Mode 2 where the limitations regarding the maximum inclination angle don't exist.

The orientation in which the Y-axis is parallel to gravity (i.e. $\pm 1g$) is not recommended when using either mode 3 or mode 4. The dynamic range in that direction is limited and it is possible that saturation flag² may give an alert even if the tilt angle is less than 10° . Performance specifications according to Table 2 are met.

SCL3300-D01 inclination measurement is based on measuring the angles between the component and the gravity vector in static environment. Note that no other accelerations should be present in order to measure angles correctly.

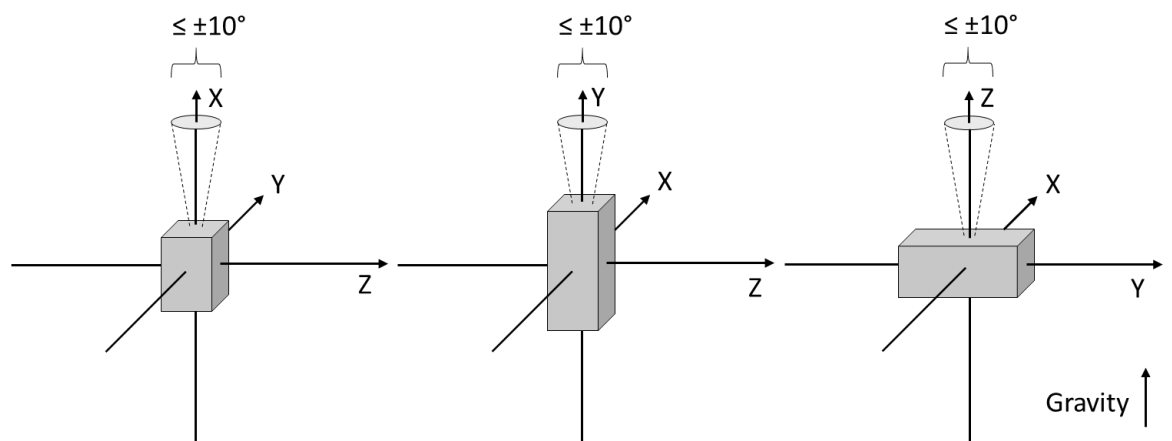

Figure 9 Measurement ranges on inclination modes (Mode 3 and Mode 4)

² See Chapter 6.3 for more information

2.12 Package Characteristics

2.12.1 Package Outline Drawing

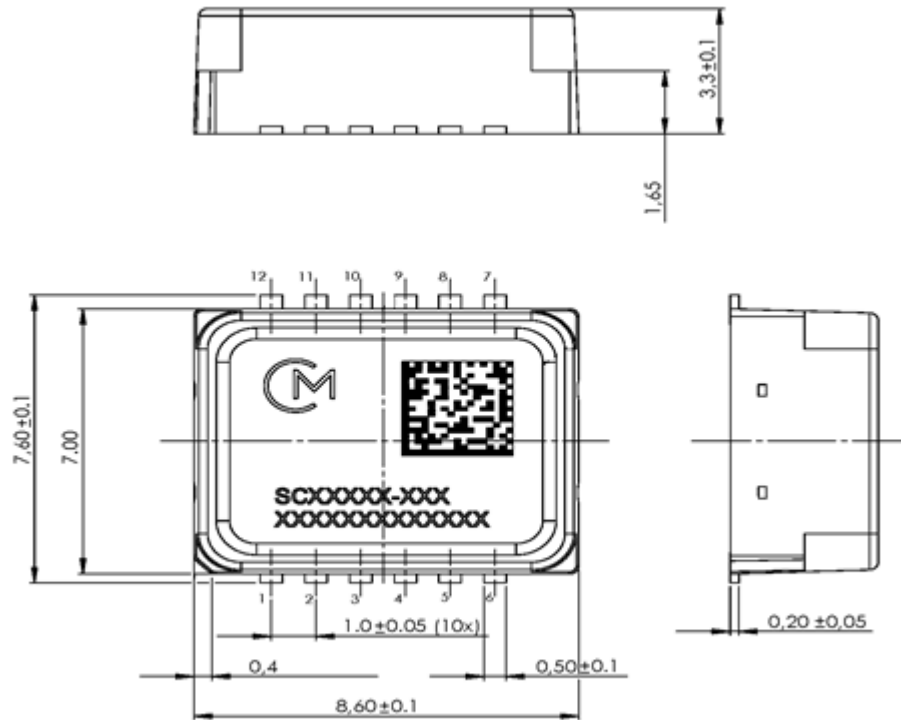

Figure 10 Package outline. The tolerances are according to ISO2768-f (see Table 10).

Table 10 Limits for linear measures (ISO2768-f).

Tolerance class	Limits in mm for nominal size in mm		
	0.5 to 3	Above 3 to 6	Above 6 to 30
f (fine)	±0.05	±0.05	±0.1

2.13 PCB Footprint

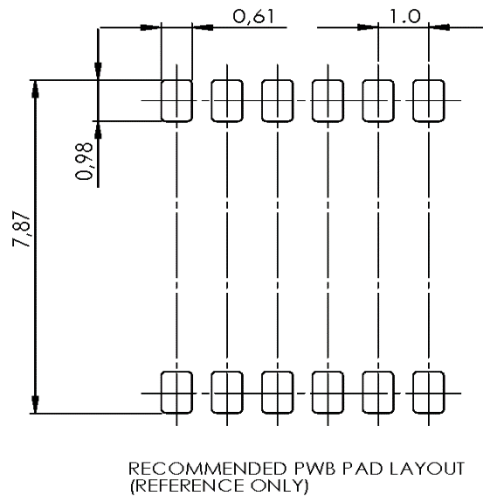

Figure 11 Recommended PWB pad layout for SCL3300-D01. All dimensions are in mm. The tolerances are according to ISO2768-f (see Table 10).

3 General Product Description

The SCL3300-D01 sensor includes acceleration sensing element and Application-Specific Integrated Circuit (ASIC). Figure 12 contains an upper level block diagram of the component.

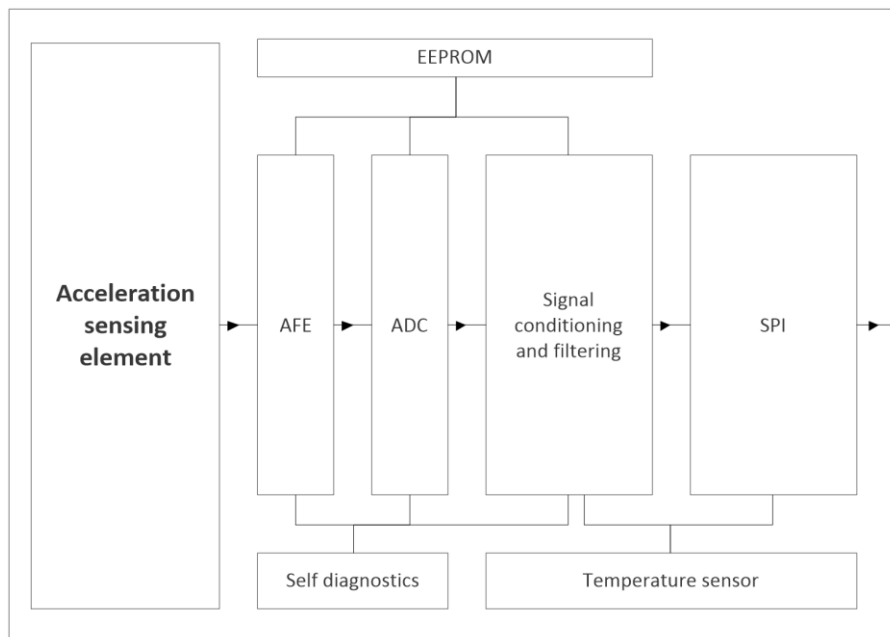

Figure 12. SCL3300-D01 component block diagram.

The sensing elements are manufactured using Murata proprietary High Aspect Ratio (HAR) 3D-MEMS process, which enables making robust, extremely stable and low noise capacitive sensors.

The acceleration sensing element consists of four acceleration sensitive masses. Acceleration causes capacitance change that is converted into a voltage change in the signal conditioning ASIC.

3.1 Factory Calibration

SCL3300-D01 sensors are factory calibrated. No separate calibration is required in the application. Calibration parameters are stored in non-volatile memory during manufacturing. The parameters are read automatically from the internal non-volatile memory during start-up.

Assembly can cause offset/bias errors to the sensor output. If best possible accuracy is required, system level offset/bias calibration (zeroing) after assembly is recommended. Offset calibration is recommended to be performed not earlier than 12 hours after reflow. It should be noted that accuracy can be improved with longer stabilization time.

4 Component Operation, Reset and Power Up

4.1 Component Operation

The Sensor ODR in normal operation mode is 2000 Hz. Registers are updated every 0.5 ms and if all data is not read the full noise performance of sensor is not met.

In order to achieve optimal performance, it is recommended that during normal operation acceleration outputs ACCX, ACCY, ACCZ are read in every cycle using sensor ODR. It is necessary to read STATUS register only if return status (RS) indicates error.

4.2 Start-up sequence

Table 11 Start-Up Sequence

Step	Procedure	RS*	Function	Note								
1	Set VDD 3.0 - 3.6 V DVIO 3.0 - 3.6 V	--		Procedure for normal startup VDD and DVIO don't need to rise at the same time								
OR												
1	Write Wake up from power down mode command	--		Procedure if device is in power down mode See Table 15 for more information								
1.2	Wait 3 ms	--	Memory reading Settling of signal path	Only needed after power down mode								
Always continue from here												
2	Write SW Reset command	--	Software reset the device	See Table 15 Operations and their equivalent SPI frames								
3	Wait 3 ms	--	Memory reading Settling of signal path									
4	Set Measurement mode**	'11'	Select operation mode	<table border="0"> <tr> <td>Mode 1 (default)</td> <td>1.2g full-scale 40 Hz 1st order low pass filter</td> </tr> <tr> <td>Mode 2</td> <td>2.4g full-scale 70 Hz 1st order low pass filter</td> </tr> <tr> <td>Mode 3</td> <td>Inclination mode 10 Hz 1st order low pass filter</td> </tr> <tr> <td>Mode 4</td> <td>Inclination mode 10 Hz 1st order low pass filter Low noise mode</td> </tr> </table>	Mode 1 (default)	1.2g full-scale 40 Hz 1st order low pass filter	Mode 2	2.4g full-scale 70 Hz 1st order low pass filter	Mode 3	Inclination mode 10 Hz 1st order low pass filter	Mode 4	Inclination mode 10 Hz 1st order low pass filter Low noise mode
Mode 1 (default)	1.2g full-scale 40 Hz 1st order low pass filter											
Mode 2	2.4g full-scale 70 Hz 1st order low pass filter											
Mode 3	Inclination mode 10 Hz 1st order low pass filter											
Mode 4	Inclination mode 10 Hz 1st order low pass filter Low noise mode											
5	Write ANG_CTRL	'01'	Enable angle outputs	See section 6.6 for more information.								
6	Wait 25 ms	--	Settling of signal path, Mode 1									
	OR Wait 15 ms	--	Settling of signal path, Mode 2									
	OR Wait 100 ms	--	Settling of signal path, Modes 3 and 4									
7	Read STATUS	'11'	Clear status summary	Reset status summary								
8	Read STATUS	'11'	Read status summary	SPI response to step 7 Read status summary. Due to SPI off-frame protocol response is before STATUS has been cleared.								
9	Read STATUS (or any other valid SPI command)	'01'	Ensure successful start-up	SPI response to step 8. First response where STATUS has been cleared. RS bits should be '01' to indicate proper start-up. Otherwise start-up has not been done correctly. See 6.3 STATUS for more information.								

* RS bits in returned SPI response during normal start-up. See 5.1.5 Return Status for more information.

** if not set, mode1 is used.

Please refer to Table 15 Operations and their equivalent SPI frames for detailed command frames.

4.3 Operation modes

SCL3300-D01 provides four user selectable operation modes.

Table 12 Operation mode description

Mode	Acceleration output			Inclination output	Acceleration and Inclination output
	Full-scale	Sensitivity LSB/g	Sensitivity LSB/° *	Sensitivity LSB/°	1 st order low pass filter
1	± 1.2 g	6000	105	182	40 Hz
2	± 2.4 g	3000	52	182	70 Hz
3	Inclination mode**	12000	209	182	10 Hz
4	Inclination mode**	12000	209	182	10 Hz

* Angle calculated using $1g \cdot \sin(\theta)$, where θ is the inclination angle relative to the 0g position. Due to characteristics of sine function sensitivity is inversely proportional to inclination angle. Reported values are valid only between 0° to ±1°.

** Inclination mode. Dynamic range is dependent on orientation in gravity.

5 Component Interfacing

5.1.1 General

SPI communication transfers data between the SPI master and registers of the SCL3300-D01 ASIC. The SCL3300-D01 always operates as a slave device in master-slave operation mode. 3-wire SPI connection is not supported.

Table 13 SPI interface pins

Pin	Pin Name	Communication
CSB	Chip Select (active low)	MCU → SCL3300
SCK	Serial Clock	MCU → SCL3300
MOSI	Master Out Slave In	MCU → SCL3300
MISO	Master In Slave Out	SCL3300 → MCU

5.1.2 Protocol

The SPI is a 32-bit 4-wire slave configured bus. Off-frame protocol is used so each transfer consists of two phases. A response to the request is sent within next request frame. The response concurrent to the request contains the data requested by the previous command. The first bit in a sequence is the MSB.

The SPI transmission is always started with the falling edge of chip select, CSB. The data bits are sampled at the rising edge of the SCK signal. The data is captured on the rising edge (MOSI line) of the SCK and it is propagated on the falling edge (MISO line) of the SCK. This equals to SPI Mode 0 (CPOL = 0 and CPHA = 0).

NOTE: For sensor operation, time between consecutive SPI requests (i.e. CSB high) must be at least 10 μ s. If less than 10 μ s is used, output data will be corrupted.

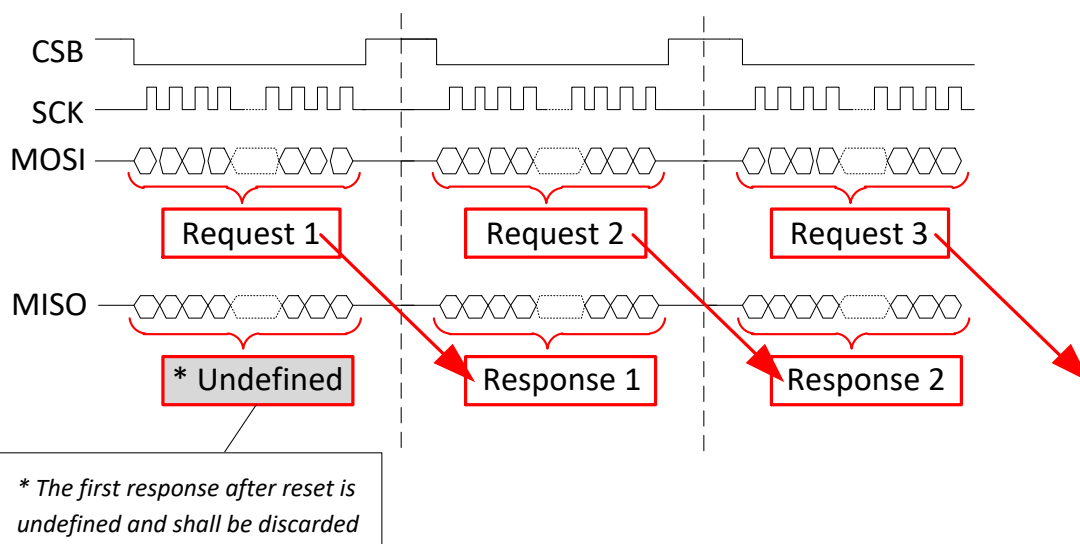

Figure 13 SPI Protocol

5.1.3 SPI frame

The SPI Frame is divided into four parts:

1. Operation Code (OP), consisting of Read/Write (RW) and Address (ADDR)
2. Return Status (RS, in MISO)
3. Data (D)
4. Checksum (CRC)

See Figure 14 and Table 14 Table 14 SPI Frame Specification for more details. For allowed SPI operating commands see Table 15.

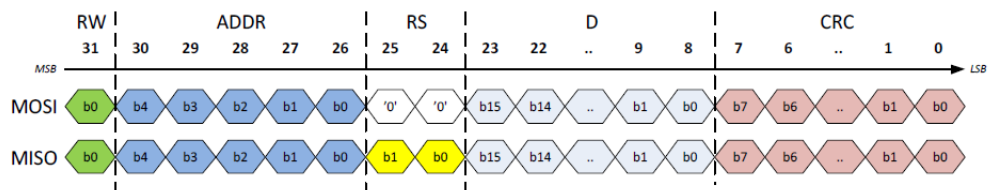

Figure 14 SPI Frame

Table 14 SPI Frame Specification

Name	Bits	Description	MISO / MOSI	
OP	[31:26]	Operation code RW + ADDR	OP [5] = RW OP [4:0] = ADDR	Read = 0 / Write = 1 Register address
RS	[25:24]	Return status	MISO '00' - Startup in progress '01' - Normal operation, no flags '10' - N/A '11' - Error	MOSI '00' - Always
D	[23:8]	Data	Returned data / data to write	
CRC	[7:0]	Checksum	See section 5.2	

Return Status (RS) shows error (i.e. '11') when an error flag (or flags) is active in, or if previous MOSI-command had incorrect CRC.

5.1.4 Operations

Allowed operation commands are shown in Table 15. No other commands are allowed.

Table 15 Operations and their equivalent SPI frames

Operation	Bank	SPI Frame	SPI Frame Hex
Read ACC_X	0 1	0000 0100 0000 0000 0000 0000 1111 0111	040000F7h
Read ACC_Y	0 1	0000 1000 0000 0000 0000 0000 1111 1101	080000FDh
Read ACC_Z	0 1	0000 1100 0000 0000 0000 0000 1111 1011	0C0000FBh
Read STO (self-test output)	0 1	0001 0000 0000 0000 0000 0000 1110 1001	100000E9h
Enable ANGLE outputs	0	1011 0000 0000 0000 0001 1111 0110 1111	B0001F6Fh
Read ANG_X	0	0010 0100 0000 0000 0000 0000 1100 0111	240000C7h
Read ANG_Y	0	0010 1000 0000 0000 0000 0000 1100 1101	280000CDh
Read ANG_Z	0	0010 1100 0000 0000 0000 0000 1100 1011	2C0000CBh
Read Temperature	0 1	0001 0100 0000 0000 0000 0000 1110 1111	140000EFh
Read Status Summary	0 1	0001 1000 0000 0000 0000 0000 1110 0101	180000E5h
Read ERR_FLAG1	0	0001 1100 0000 0000 0000 0000 1110 0011	1C0000E3
Read ERR_FLAG2	0	0010 0000 0000 0000 0000 0000 1100 0001	200000C1h
Read CMD	0	0011 0100 0000 0000 0000 0000 1101 1111	340000DFh
Change to mode 1	0	1011 0100 0000 0000 0000 0000 0001 1111	B400001Fh
Change to mode 2	0	1011 0100 0000 0000 0000 0001 0000 0010	B4000102h
Change to mode 3	0	1011 0100 0000 0000 0000 0010 0010 0101	B4000225h
Change to mode 4	0	1011 0100 0000 0000 0000 0011 0011 1000	B4000338h
Set power down mode	0	1011 0100 0000 0000 0000 0100 0110 1011	B400046Bh
Wake up from power down mode	0	1011 0100 0000 0000 0000 0000 0001 1111	B400001Fh
SW Reset	0	1011 0100 0000 0000 0010 0000 1001 1000	B4002098h
Read WHOAMI	0	0100 0000 0000 0000 0000 0000 1001 0001	40000091h
Read SERIAL1	1	0110 0100 0000 0000 0000 0000 1010 0111	640000A7h
Read SERIAL2	1	0110 1000 0000 0000 0000 0000 1010 1101	680000ADh
Read current bank	0 1	0111 1100 0000 0000 0000 0000 1011 0011	7C0000B3h
Switch to bank #0	0 1	1111 1100 0000 0000 0000 0000 0111 0011	FC000073h
Switch to bank #1	0 1	1111 1100 0000 0000 0000 0001 0110 1110	FC00016Eh

5.1.5 Return Status

SPI frame Return Status bits (RS bits) indicate the functional status of the sensor. See Table 16 for RS definitions.

Table 16 Return Status definitions

RS [1]	RS [0]	Description
0	0	Startup in progress
0	1	Normal operation, no flags
1	0	Reserved
1	1	Error

The priority of the return status states is from high to low: 00 → 11 → 01

Return Status (RS) shows error (i.e. '11') when an error flag (or flags) is active in Status Summary register, or if previous MOSI-command had incorrect frame CRC. If the Status Summary register is read immediately after a shock event, the RS bits may indicate an error (RS = '11'), even though the STATUS register data content is '0000'. In the subsequent frame, if the STATUS register data content remains '0000', this indicates that the cause was a CRC error. In the case of a saturation error, the data content will indicate that. For example, STATUS = '0040'.

See Table 27 for description of the Status Summary register.

5.2 Checksum (CRC)

For SPI transmission error detection a Cyclic Redundancy Check (CRC) is implemented, for details see Table 17.

Table 17 SPI CRC definition

Parameter	Value
Name	CRC-8
Width	8 bit
Poly	1Dh (generator polynom: $X^8+X^4+X^3+X^2+1$)
Init	FFh (initialization value)
XOR out	FFh (inversion of CRC result)

The CRC value used in system level software has to be initialized with FFh to ensure a CRC failure in case of stuck-at-0 and stuck-at-1 error on the SPI bus. C-programming language example for CRC calculation is presented in Figure 15. It can be used as is in an appropriate programming context.

```

// Calculate CRC for 24 MSB's of the 32 bit dword
// (8 LSB's are the CRC field and are not included in CRC calculation)

uint8_t CalculateCRC(uint32_t Data)
{
    uint8_t BitIndex;
    uint8_t BitValue;
    uint8_t CRC;

    CRC = 0xFF;
    for (BitIndex = 31; BitIndex > 7; BitIndex--)
    {
        BitValue = (uint8_t)((Data >> BitIndex) & 0x01);
        CRC = CRC8(BitValue, CRC);
    }
    CRC = (uint8_t)~CRC;
    return CRC;
}

static uint8_t CRC8(uint8_t BitValue, uint8_t CRC)
{
    uint8_t Temp;

    Temp = (uint8_t)(CRC & 0x80);
    if (BitValue == 0x01)
    {
        Temp ^= 0x80;
    }
    CRC <<= 1;
    if (Temp > 0)
    {
        CRC ^= 0x1D;
    }
    return CRC;
}

```

Figure 15 C-programming language example for CRC calculation

In case of wrong CRC in MOSI write/read, RS bits “11” are set in the next SPI response, STATUS register is not changed, and write command is discarded. If CRC in MISO SPI response is incorrect, communication failure occurred.

CRC calculation example:

```

Read ACC_X register (04h)
SPI [31:8] = 040000h → CRC = F7h
SPI [7:0]  = F7h
SPI frame  = 040000F7h

```

6 Register Definition

SCL3300-D01 contains two user switchable register banks. Default register bank is #0. One should have register bank #0 always active, unless data from bank #1 is required. After reading data from bank #1 is finished, one should switch back to bank #0 to ensure no accidental read / writes in unwanted registers. See 6.9 SELBANK for more information for selecting active register bank. Table 18 shows overview of register banks and register addresses.

Table 18 Register address space overview

Addr (hex)	Read/Write	Register Bank		Description
		#0	#1	
01h	R	ACC_X	ACC_X	X-axis acceleration output in 2's complement format
02h	R	ACC_Y	ACC_Y	Y-axis acceleration output in 2's complement format
03h	R	ACC_Z	ACC_Z	Z-axis acceleration output in 2's complement format
04h	R	STO	STO	Self-test output in 2's complement format
05h	R	TEMPERATURE	TEMPERATURE	Temperature sensor output in 2's complement format
06h	R	STATUS	STATUS	Status Summary combining ERR_FLAG1 and ERR_FLAG2
07h	R	ERR_FLAG1	reserved	Error flags group1
08h	R	ERR_FLAG2	reserved	Error flags group2
09h	-	ANG_X	reserved	X-axis angle output in 2's complement format X-axis angle output is a positive integer from 0 to 65536
0Ah	-	ANG_Y	reserved	Y-axis angle output in 2's complement format Y-axis angle output is a positive integer from 0 to 65536
0Bh	-	ANG_Z	reserved	Z-axis angle output in 2's complement format Z-axis angle output is a positive integer from 0 to 65536
0Ch	-	ANG_CTRL	reserved	Enable angle outputs
0Dh	R / W	MODE	reserved	Sets operation mode, SW Reset and Power down mode
0Eh	-	reserved	reserved	-
0Fh	-	reserved	reserved	-
10h	R	WHOAMI	reserved	8-bit register for component identification
11h	-	reserved	reserved	-
12h	-	reserved	reserved	-
13h	-	reserved	reserved	-
14h	-	reserved	reserved	-
15h	-	reserved	reserved	-
16h	-	reserved	reserved	-
17h	-	reserved	reserved	-
18h	-	reserved	reserved	-
19h	R	reserved	SERIAL1	Component serial part 1
1Ah	R	reserved	SERIAL2	Component serial part 2
1Bh	-	reserved	Factory Use	-
1Ch	-	reserved	Factory Use	-
1Dh	-	reserved	Factory Use	-
1Eh	-	reserved	reserved	-
1Fh	R / W	SELBANK	SELBANK	Switch between active register banks

User should not access Reserved nor Factory Use registers. Power-cycle, reset and power down mode will reset all written settings.

6.1 Sensor Data Block

Table 19 Sensor data block description

Bank	Addr	Name	No. of bits	Read / Write	Description
0 1	01h	ACC_X	16	R	X-axis acceleration output in 2's complement format
0 1	02h	ACC_Y	16	R	Y-axis acceleration output in 2's complement format
0 1	03h	ACC_Z	16	R	Z-axis acceleration output in 2's complement format
0 1	05h	TEMPERATURE	16	R	Temperature sensor output in 2's complement format. See section 2.4 for conversion equation.
0	09h	ANG_X	16	R	X-axis angle output in 2's complement format See section 6.1.3 for conversion equation.
0	0Ah	ANG_Y	16	R	Y-axis angle output in 2's complement format See section 6.1.3 for conversion equation.
0	0Bh	ANG_Z	16	R	Z-axis angle output in 2's complement format See section 6.1.3 for conversion equation.

Table 20 Sensor data block operations

Operation	SPI Frame	SPI Frame Hex
Read ACC_X	0000 0100 0000 0000 0000 0000 1111 0111	040000F7h
Read ACC_Y	0000 1000 0000 0000 0000 0000 1111 1101	080000FDh
Read ACC_Z	0000 1100 0000 0000 0000 0000 1111 1011	0C0000FBh
Read Temperature	0001 0100 0000 0000 0000 0000 1110 1111	140000EFh
Read ANG_X	0010 0100 0000 0000 0000 0000 1100 0111	240000C7h
Read ANG_Y	0010 1000 0000 0000 0000 0000 1100 1101	280000CDh
Read ANG_Z	0010 1100 0000 0000 0000 0000 1100 1011	2C0000CBh

6.1.1 Example of Acceleration Data Conversion

For example, if ACC_X register read results: ACC_X = 0500DC1Ch, the register content is converted to acceleration rate as follows:

OP[31:26] +		Data[23:8]				CRC[7:0]	
RS[25:24]							
0	5	0	0	D	C	1	C

OP + RS

05h = 0000 0101b
 0000 01b = OP code = Read ACC_X
 01b = return status (RS bits) = no error

Data = ACC_X register content

00DCh
 00DCh → 220d = in 2's complement format
 Acceleration:
 = 220 LSB / sensitivity(mode1)
 = 220 LSB / 6000 LSB/g
 = 0.0367 g

CRC

1Ch
 CRC of 0500DCh, see section 5.2

6.1.2 Example of Temperature Data Conversion

For example, if TEMPERATURE register read results: TEMPERATURE = 15161E0Ah, the register content is converted to temperature as follows:

OP[31:26] +		Data[23:8]				CRC[7:0]	
RS[25:24]							
1	5	1	6	1	E	0	A

OP + RS

15h = 0001 0101b
 0001 01b = OP code = Read TEMP
 01b = return status (RS bits) = no error

Data = TEMPERATURE register content

161Eh

161Eh → 5662d = in 2's complement format

Temperature:

= -273 + (5662 / 18.9)

= +26.6°C

CRC

0Ah

CRC of 15161Eh, see section 5.2

6.1.3 Example of Angle Data Conversion

Angle outputs must be enabled before angles can be read from registers. See section 6.6 for details.

For example, if ANG_X register read results: ANG_X = 250F8825h, the register content is converted to angle (degrees) as follows:

OP[31:26] +		Data[23:8]				CRC[7:0]	
RS[25:24]							
2	5	0	F	8	8	2	5

OP + RS

25h = 0010 0101b
 0010 01b
 01b

= OP code = Read ANG_X
 = return status (RS bits) = no error

Data = ANG_X register content
 0F88h

0F88h → 3976d = in 2's complement format
 Angle in degrees:
 = $3976/2^{14} \times 90$
 = 21.84°

CRC

25h

CRC of 250F88h, see section 5.2

6.2 STO

Table 21 STO (self-test output) description

Bank	Addr	Name	No. of bits	Read / Write	Description
0 1	04h	STO	16	R	Self-test output in 2's complement format

Table 22 STO operation

Operation	SPI Frame	SPI Frame Hex
Read STO (self-test output)	0001 0000 0000 0000 0000 0000 1110 1001	100000E9h

If self-test option is desired in application, following guidelines should be taken into account. STO is used to monitor if accelerometer is functioning correctly. It provides information on signal saturation during vibration and shock events. STO should be read continuously in the normal operation sequence after XYZ acceleration readings.

STO threshold monitoring should be implemented on application software. Failure thresholds and failure tolerant time of the system are application specific and should be carefully validated. Monitoring can be implemented by counting the subsequent “STO signal exceeding threshold” –events. Examples for STO thresholds are shown in Table 23.

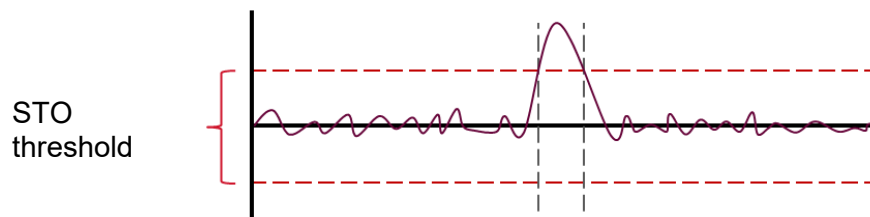

Failure-tolerant time, e.g. event counter
how many times threshold is exceeded

Component failure can be suspected if the STO signal exceeds the threshold level continuously after performing component hard reset in static (no vibration) condition.

Table 23 Examples for STO Thresholds

Mode	Full-scale	Examples for STO thresholds
1	± 1.2g	±1800 LSB
2	± 2.4g	±900 LSB
3	Inclination mode ³	±3600 LSB
4	Inclination mode ³	±3600 LSB

³ Inclination mode. Dynamic range is dependent on orientation in gravity. See 2.11.1

6.2.1 Example of Self-Test Analysis

For example, if STO register read results: STO = 1100017Bh, the register value can be converted as follows:

OP[31:26] +		Data[23:8]				CRC[7:0]	
RS[25:24]							
1	1	0	0	0	1	7	B

OP + RS

11h = 0001 0001b
 0001 00b = OP code = Read STO
 01b = return status (RS bits) = no error

Data = STO register content

0001h
 0001h → 1d = in 2's complement format
 Self-test reading:
 = 1
 See Table 12 for recommended STO threshold values

CRC

7Bh
 CRC of 110001h, see section 5.2

6.3 STATUS

Table 24 STATUS description

Bank	Addr	Name	No. of bits	Read / Write	Description
0 1	06h	STATUS	16	R	Status Summary combining ERR_FLAG1 and ERR_FLAG2

Table 25 STATUS operation

Operation	SPI Frame	SPI Frame Hex
Read Status Summary	0001 1000 0000 0000 0000 0000 1110 0101	180000E5h

Table 26 STATUS register

D15	D14	D13	D12	D11	D10	D9	D8	D7	D6	D5	D4	D3	D2	D1	D0	Bit
Reserved						DIGI1	DIGI2	CLK	SAT	TEMP	PWR	MEM	PD	MODE_CHANGE	PIN_CONTINUITY	Read

Table 27 STATUS register bit description

Bit	Name	Description	Required action/explanation
9	DIGI1	Digital block error type 1	SW or HW reset needed
8	DIGI2	Digital block error type 2	SW or HW reset needed
7	CLK	Clock error	SW or HW reset needed
6	SAT	Signal saturated in signal path	Acceleration too high and acceleration and inclination readings not usable. Component failure possible. All acceleration, inclination, and STO output data is invalid.
5	TEMP	Temperature signal path saturated	External temperature too high or low. Component failure possible
4	PWR	Start-up indication or Voltage level failure	[After start-up or reset] This flag is set high. No actions needed.
			[During normal operation] External voltages too high or low. Component failure possible. SW or HW reset needed.
3	MEM	Error in non-volatile memory	Memory check failed. Possible component failure SW or HW reset needed.
2	PD	Device in power down mode	If power down is not requested. SW or HW reset needed
1	MODE_CHANGE	Operation mode changed	Bit is set high if operation mode has been changed If mode change is not requested SW or HW reset needed
0	PIN_CONTINUITY	Component internal connection error	Possible component failure

Status register indicates saturation or failure in component. Failure is indicated by setting the status flag to 1.

Software (SW) reset is done with SPI operation (see 5.1.4). Hardware (HW) reset is done by power cycling the sensor. If these do not reset the error, then possible component error has occurred and system needs to be shut down and part returned to supplier.

6.3.1 Example of STATUS summary reset

The STATUS summary is cleared by reading the register. The example below shows the MOSI commands and corresponding MISO responses for the “Read STATUS summary” command when the SAT bit is set in the STATUS summary (data = 0x0040).

Step #1: Due to the SPI off-frame protocol, the first MISO response corresponds to the previous MOSI command and is therefore not relevant in this example (“don’t care”). Step #2: The Return Status (RS) bits indicate an error (b’11) in the response to the MOSI command. Step #3: After the MOSI command, the Return Status (RS) bits are cleared (b’01). Step #4: After the MOSI command, the SAT bit is also cleared, and the returned STATUS data is 0x0000.

The definition of the Return Status bits is provided in Chapter 5.1.5.

Step #	MOSI command	MISO response	Return Status bits (RS)	Data
1	0x180000E5	<i>don't care</i>	b'11	<i>don't care</i>
2	0x180000E5	0x1b00407a	b'11	0x0040
3	0x180000E5	0x19004079	b'01	0x0040
4	0x180000E5	0x1900006a	b'01	0x0000

6.4 Error Flag Block

Table 28 Error flag block description

Bank	Addr	Register Name	No. of bits	Read / Write	Description
0	07h	ERR_FLAG1	16	R	Error flags
0	08h	ERR_FLAG2	16	R	Error flags

Table 29 Error flag block operations

Operation	SPI Frame	SPI Frame Hex
Read ERR_FLAG1	0001 1100 0000 0000 0000 0000 1110 0011	1C0000E3
Read ERR_FLAG2	0010 0000 0000 0000 0000 0000 1100 0001	200000C1h

ERR_FLAG registers indicate saturation or failure in the component. Failure is indicated by setting the error flag to 1.

STATUS register contains combination of the information in the ERR_FLAG1 and ERR_FLAG2 registers; if there is an error, it is reflected in STATUS. ERR_FLAG registers can be used to further assess reason for error. Note that reading ERR_FLAG registers does not reset error flags in STATUS register nor reset RS bits.

6.4.1 ERR_FLAG1

Table 30 ERR_FLAG1 register

D15	D14	D13	D12	D11	D10	D9	D8	D7	D6	D5	D4	D3	D2	D1	D0	Bit
Reserved				ADC_SAT	AFE_SAT										MEM	Read

Table 31 ERR_FLAG1 register bit description

Bit	Name	Description
15:12	Reserved	Reserved
11	ADC_SAT	Signal saturated at analog-to-digital converter
10:1	AFE_SAT	Signal saturated at analog front-end circuitry
0	MEM	Error in non-volatile memory

6.4.2 ERR_FLAG2

Table 32 ERR_FLAG2 register

D15	D14	D13	D12	D11	D10	D9	D8	D7	D6	D5	D4	D3	D2	D1	D0	Bit
Reserved	D_EXT_C	A_AEXT_C	AGND	VDD	Reserved	MODE_CHANGE	PD	MEMORY_CRC	Reserved	APWR	DPWR	REFV	APWR_2	TEMP_SAT	CLK	Read

Table 33 ERR_FLAG2 register bit description

Bit	Name	Description
15	Reserved	Reserved
14	D_EXT_C	External capacitor connection error
13	A_EXT_C	External capacitor connection error
12	AGND	Analog ground connection error
11	VDD	Supply voltage error
10	Reserved	Reserved
9	MODE_CHANGE	Operation mode changed by user
8	PD	Device in power down mode
7	MEMORY_CRC	Memory CRC check failed
6	Reserved	Reserved
5	APWR	Analog power error
4	DPWR	[After start-up or reset] This flag is set high. No actions needed.
		[During normal operation] Digital power error. Component failure possible. SW or HW reset needed.
3	VREF	Reference voltage error
2	APWR_2	Analog power error
1	TEMP_SAT	Temperature signal path saturated
0	CLK	Clock error

6.5 CMD

Table 34 CMD description

Bank	Addr	Register Name	No. of bits	Read / Write	Description
0	0Dh	CMD	16	R / W	Sets operation mode, SW Reset and Power down mode

Table 35 CMD operations

Command	SPI Frame	SPI Frame hex
Read CMD	0011 0100 0000 0000 0000 0000 1101 1111	34000DFh
Change to mode1	1011 0100 0000 0000 0000 0000 0001 1111	B40001Fh
Change to mode2	1011 0100 0000 0000 0000 0001 0000 0010	B400102h
Change to mode3	1011 0100 0000 0000 0000 0010 0010 0101	B400225h
Change to mode4	1011 0100 0000 0000 0000 0011 0011 1000	B400338h
Set power down mode	1011 0100 0000 0000 0000 0100 0110 1011	B40046Bh
Wake up from power down mode	1011 0100 0000 0000 0000 0000 0001 1111	B40001Fh
SW Reset	1011 0100 0000 0000 0010 0000 1001 1000	B4002098h

Table 36 CMD register

D15	D14	D13	D12	D11	D10	D9	D8	D7	D6	D5	D4	D3	D2	D1	D0	Bit
Reserved								Factory use	Factory use	SW_RST	Factory use	Factory use	PD	MODE		Read

Table 37 CMD register bit description

Bit	Name	Description
15:8	Reserved	Reserved
7	Factory use	Factory use
6	Factory use	Factory use
5	SW_RST	Software (SW) Reset
4	Factory use	Factory use
3	Factory use	Factory use
2	PD	Power Down
1:0	MODE	Operation Mode

Sets operation mode of the SCL3300-D01. After power-off, reset (SW or HW), power down mode or unintentional power-off, normal start-up sequence must be followed. Note: mode will be set to default mode1.

Operation modes are described in section 4.3.

Changing mode will set Status Summary bit 1 to high, setting / waking up from power down mode will set Status Summary bit 2 to high (see 6.3.) Thus RS bits will show '11' (see 5.1.5.). **Note:** User must not configure other than given valid commands, otherwise power-off, reset, or power down is required.

6.6 ANG_CTRL

Table 38 ANG_CTRL description

Bank	Addr	Register Name	No. of bits	Read / Write	Description
0	0Ch	ANG_CTRL	16	W	Enable angle outputs.

Table 39 ANG_CTRL operations

Command	SPI Frame	SPI Frame hex
Enable Angle Outputs	1011 0000 0000 0000 0001 1111 0110 1111	B0001F6Fh

Table 40 ANG_CTRL register

D15	D14	D13	D12	D11	D10	D9	D8	D7	D6	D5	D4	D3	D2	D1	D0	Bit
Not Used [15:5]											Enable Angle Outputs [4:0] = b'11111				Write	

ANG_CTRL is a 5-bit registers to control angle outputs. Default value for register is 00h. Angle outputs are enabled by writing 1Fh to ANG_CTRL.

6.7 WHOAMI

Table 41 WHOAMI description

Bank	Addr	Register Name	No. of bits	Read / Write	Description
0	10h	WHOAMI	8	R	8-bit register for component identification

Table 42 WHOAMI operations

Operation	SPI Frame	SPI Frame Hex
Read WHOAMI	0100 0000 0000 0000 0000 0000 1001 0001	40000091h

Table 43 WHOAMI register

D15	D14	D13	D12	D11	D10	D9	D8	D7	D6	D5	D4	D3	D2	D1	D0	Bit
								-	-	-	-	-	-	-	-	Write
Not Used [15:8]								Component ID [7:0] = C1h							Read	

WHOAMI is a 8-bit register for component identification. Returned value is C1h.

Note: as returned value is fixed, this can be used to ensure SPI communication is working correctly.

6.8 Serial Block

Table 44 Serial block description

Bank	Addr	Register Name	No. of bits	Read / Write	Description
1	19h	SERIAL1	16	R	Component serial part 1
1	1Ah	SERIAL2	16	R	Component serial part 2

Table 45 Serial block operations

Operation	SPI Frame	SPI Frame Hex
Read SERIAL1	0110 0100 0000 0000 0000 0000 1010 0111	640000A7h
Read SERIAL2	0110 1000 0000 0000 0000 0000 1010 1101	680000ADh

Serial Block contains sensor serial number in two 16 bit registers in register bank #1, see 6.5 CMD for information how to switch register banks. The same serial number is also written on top of the sensor.

The following procedure is recommended when reading serial number:

1. Change active register bank to #1
2. Read registers 19h and 1Ah
3. Change active register back to bank #0
4. Resolve serial number:
 1. Combine result data from 1Ah[16:31] and 19h[0:15]
 2. Convert HEX to DEC
 3. Add letters "B33" to end

6.8.1 Example of Resolving Serial Number

1. Change active register bank to #1
SPI Request SWITCH_TO_BANK_1
Request: FC00016E
Response: XXXXXXXX, response to previous command

2. Read registers 19h and 1Ah
SPI Request READ_SERIAL1:
Request: 640000A7
Response: FD0001E1, response to switch command

SPI Request READ_SERIAL2:
Request: 680000AD
Response: 65F7DA19, response to serial1, data: F7DA

3. Change active register back to bank #0
SPI Request SWITCH_TO_BANK_0
Request: FC000073
Response: 693CE54F, response to serial2, data: 3CE5

4. Resolve serial number
 1. Combined Serial number: 3CE5F7DA
 2. HEX to DEC: 1021704154
 3. Add "B33": 1021704154B33

→ Full Serial number: 1021704154B33

6.9 SELBANK

Table 46 SELBANK description

Bank	Addr	Register Name	No. of bits	Read / Write	Description
0 1	1Fh	SELBANK	16	R	Switch between active register banks

Table 47 SELBANK operations

Command	SPI Frame	SPI Frame hex
Read current bank	0111 1100 0000 0000 0000 0000 1011 0011	7C0000B3h
Switch to bank #0	1111 1100 0000 0000 0000 0000 0111 0011	FC000073h
Switch to bank #1	1111 1100 0000 0000 0000 0001 0110 1110	FC00016Eh

SELBANK is used to switch between memory banks #0 and #1. It's recommended to keep memory bank #0 selected unless register from bank #1 is required, for example, reading serial number of sensor. After using bank #1 user should switch back to bank #0.

7 Application information

7.1 Application Circuitry and External Component Characteristics

See Figure 16 and Table 48 for specification of the external components. The PCB layout example is shown in Figure 17.

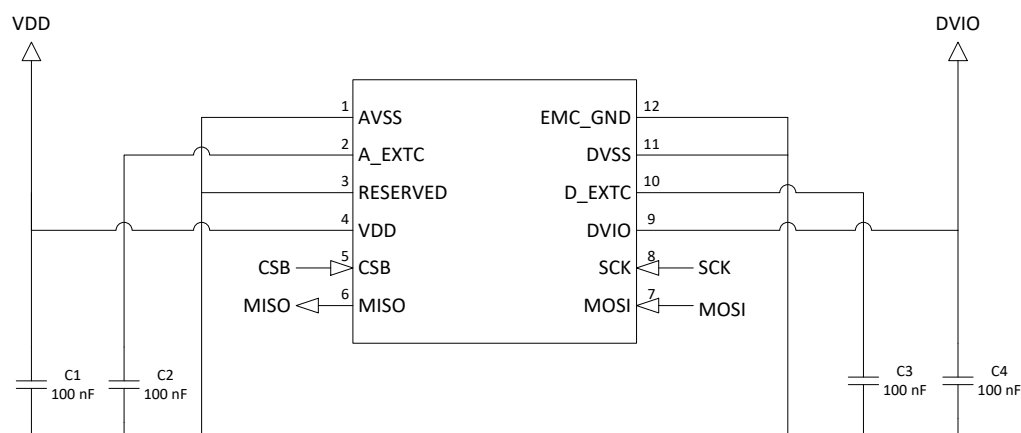

Figure 16 Application schematic.

Table 48 External component description for SCL3300-D01.

Symbol	Description	Min.	Nom.	Max.	Unit
C1	Decoupling capacitor between VDD and GND Recommended component: Murata GCM155R71C104KA55, 0402, 16V, X7R ESR Please confirm capacitor availability from www.murata.com	70	100		nF mΩ
C2	Decoupling capacitor between A_EXTC and GND Recommended component: Murata GCM155R71C104KA55, 0402, 16V, X7R ESR Please confirm capacitor availability from www.murata.com	70	100	130 100	nF mΩ
C3	Decoupling capacitor between D_EXTC and GND Recommended component: Murata GCM155R71C104KA55, 0402, 16V, X7R ESR Please confirm capacitor availability from www.murata.com	70	100	130 100	nF mΩ
C4	Decoupling capacitor between DVIO and GND Recommended component: Murata GCM155R71C104KA55, 0402, 16V, X7R ESR Please confirm capacitor availability from www.murata.com	70	100		nF mΩ

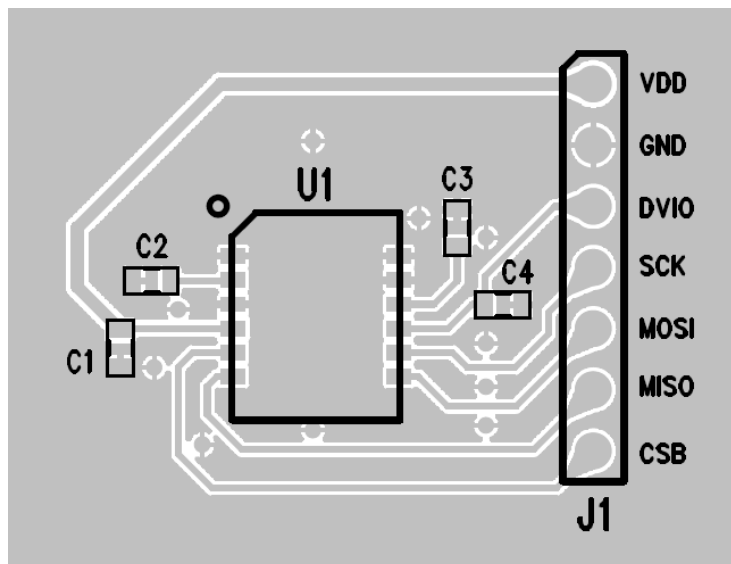

Figure 17. Application PCB layout.

General circuit diagram and PCB layout recommendations for SCL3300-D01:

1. Connect decoupling SMD capacitors (C1 - C4) right next to respective component pins.
2. Place ground plate under component.
3. Do not route signals or power supplies under the component on top layer.
4. Ensure good ground connection of DVSS, AVSS and EMC_GND pins

7.2 Assembly Instructions

The Moisture Sensitivity Level of the component is Level 3 according to the IPC/JEDEC JSTD-020C. The part is delivered in a dry pack. The manufacturing floor time (out of bag) at the customer's end is 168 hours.

Usage of PCB coating materials may penetrate component lid and affect component performance. PCB coating is not allowed.

Sensor components shall not be exposed to chemicals that are known to react with silicones, such as solvents. Sensor components shall not be exposed to chemicals with high impurity levels, such as Cl⁻, Na⁺, NO₃⁻, SO₄⁻, NH₄⁺ in excess of >10 ppm. Flame retardants such as Br or P containing materials shall be avoided in close vicinity of sensor component. Materials with high amount of volatile content should also be avoided.

If heat stabilized polymers are used in application, user should check that no iodine, or other halogen, containing additives are used.

For additional assembly related details please refer to technical note Assembly instructions of Dual Flat Lead Package (DFL).

APP 2702 Assembly_Instructions_for_DFL_Package

8 Traceability

Each sensor is assigned a unique serial number at the assembly line, which is printed on the component housing and stored in the ASIC's internal memory. This serial number allows full traceability of the entire bill of materials. Test data can be traced from final component tests down to individual MEMS and ASIC level test data. Traceability data also enables tracking of consumables and production equipment.

9 Frequently Asked Questions

- How can I be sure SPI communication is working?
 - Read register WHOAMI (10h), the response should be C1h.
- Why do I get wrong results when I read data?
 - SCL3300-D01 uses off-frame protocol (see 5.1.2 Protocol), make sure to utilize this correctly.
 - Confirm time between SPI requests (CSB high) is at least 10 μs.
 - Ensure SCL3300-D01 is correctly started (see 4.2 Start-up sequence).
 - Read RS bits (see 5.1.5 Return Status), if error is shown read Status Summary (see 6.3 STATUS) for further information.
 - Confirm correct sensitivity is used for current operation mode (see 4.3 Operation modes)
- Why all angle outputs read only zeroes?
 - Ensure that angle outputs are enabled after startup (see 4.2 Start-up sequence and 6.6 ANG_CTRL)

10 Order Information

Order Code	Description	Packing	Qty
SCL3300-D01-004	3-axis inclinometer with digital SPI interface This order code is only for samples. Not for production.	Bulk	4pcs
SCL3300-D01-1	3-axis inclinometer with digital SPI interface	T&R	100pcs
SCL3300-D01-10	3-axis inclinometer with digital SPI interface	T&R	1000pcs

Murata reserves all rights to modify this document without prior notice.