

---

---

## USB 2.0 Hi-Speed Hub Controller

---

---

### General Description

The Microchip USB251xB/xBi hub is a family of low-power, configurable, MTT (multi transaction translator) hub controller IC products for embedded USB solutions. The *x* in the part number indicates the number of downstream ports available, while the *B* indicates battery charging support. The Microchip hub supports low-speed, full-speed, and hi-speed (if operating as a hi-speed hub) downstream devices on all of the enabled downstream ports.

### Highlights

- High performance, low-power, small footprint hub controller IC with 2, 3, or 4 downstream ports
- Fully compliant with the *USB 2.0 Specification* [1]
- Enhanced OEM configuration options available through either a single serial I<sup>2</sup>C EEPROM, or SMBus slave port
- **MultiTRAK™**
  - High-performance multiple transaction translator which provides one transaction translator per port
- **PortMap**
  - Flexible port mapping and disable sequencing
- **PortSwap**
  - Programmable USB differential-pair pin locations ease PCB design by aligning USB signal lines directly to connectors
- **PHYBoost**
  - Programmable USB signal drive strength for recovering signal integrity using 4-level driving strength resolution

### Features

- USB251xB/xBi products are fully footprint compatible with USB251x/xi/xA/xAi products as direct drop-in replacements
  - Cost savings include using the same PCB components and application of USB-IF Compliance by Similarity
- Full power management with individual or ganged power control of each downstream port
- Fully integrated USB termination and pull-up/pull-down resistors
- Supports a single external 3.3 V supply source; internal regulators provide 1.2 V internal core voltage
- Onboard 24 MHz crystal driver or external 24 MHz clock input
- Customizable vendor ID, product ID, and device ID
- 4 kilovolts of HBM JESD22-A114F ESD protection (powered and unpowered)
- Supports self- or bus-powered operation
- Supports the USB Battery Charging specification Rev. 1.1 for Charging Downstream Ports (CDP)
- The USB251xB/xBi offers the following packages:
  - 36-pin SQFN (6x6 mm) (Preferred)
  - 36-pin QFN (6x6 mm) (Legacy)
- USB251xBi products support the industrial temperature range of -40°C to +85°C
- USB251xB products support the extended commercial temperature range of 0°C to +85°C

### Applications

- LCD monitors and TVs
- Multi-function USB peripherals
- PC motherboards
- Set-top boxes, DVD players, DVR/PVR
- Printers and scanners
- PC media drive bay
- Portable hub boxes
- Mobile PC docking
- Embedded systems

# USB251xB/xBi

---

---

## TO OUR VALUED CUSTOMERS

It is our intention to provide our valued customers with the best documentation possible to ensure successful use of your Microchip products. To this end, we will continue to improve our publications to better suit your needs. Our publications will be refined and enhanced as new volumes and updates are introduced.

If you have any questions or comments regarding this publication, please contact the Marketing Communications Department via E-mail at [docerrors@microchip.com](mailto:docerrors@microchip.com). We welcome your feedback.

### Most Current Data Sheet

To obtain the most up-to-date version of this data sheet, please register at our Worldwide Web site at:

<http://www.microchip.com>

You can determine the version of a data sheet by examining its literature number found on the bottom outside corner of any page. The last character of the literature number is the version number, (e.g., DS30000000A is version A of document DS30000000).

### Errata

An errata sheet, describing minor operational differences from the data sheet and recommended workarounds, may exist for current devices. As device/documentation issues become known to us, we will publish an errata sheet. The errata will specify the revision of silicon and revision of document to which it applies.

To determine if an errata sheet exists for a particular device, please check with one of the following:

- Microchip's Worldwide Web site; <http://www.microchip.com>
- Your local Microchip sales office (see last page)

When contacting a sales office, please specify which device, revision of silicon and data sheet (include -literature number) you are using.

### Customer Notification System

Register on our web site at [www.microchip.com](http://www.microchip.com) to receive the most current information on all of our products.

## Table of Contents

1.0 Introduction .....	4
2.0 Block Diagram .....	6
3.0 Pin Information .....	7
4.0 Battery Charging Support .....	17
5.0 Initial Interface/Configuration Options .....	19
6.0 DC Parameters .....	39
7.0 AC Specifications .....	44
8.0 Package Marking Information .....	46
9.0 Package Information .....	48
Appendix A: Acronyms .....	50
Appendix B: References .....	51
Appendix C: Data Sheet Revision History .....	52
The Microchip Web Site .....	54
Customer Change Notification Service .....	54
Customer Support .....	54
Product Identification System .....	55

# USB251xB/xBi

---

## 1.0 INTRODUCTION

The Microchip USB251xB/xBi hub family is a group of low-power, configurable, MTT (multi transaction translator) hub controller ICs. The hub provides downstream ports for embedded USB solutions and is fully compliant with the *USB 2.0 Specification* [1]. Each of the hub controllers can attach to an upstream port as a full-speed or full-/hi-speed hub. The hub can support low-speed, full-speed, and hi-speed downstream devices when operating as a hi-speed hub.

All required resistors on the USB ports are integrated into the hub. This includes all series termination resistors and all required pull-down and pull-up resistors on D+ and D- pins. The over-current sense inputs for the downstream facing ports have internal pull-up resistors.

The USB251xB/xBi hub family includes programmable features, such as:

- **MultiTRAK™ Technology:** implements a dedicated Transaction Translator (TT) for each port. Dedicated TTs help maintain consistent full-speed data throughput regardless of the number of active downstream connections.
- **PortMap:** provides flexible port mapping and disable sequences. The downstream ports of a USB251xB/xBi hub can be reordered or disabled in any sequence to support multiple platform designs with minimum effort. For any port that is disabled, the USB251xB/xBi hub controller automatically reorders the remaining ports to match the USB host controller's port numbering scheme.
- **PortSwap:** allows direct alignment of USB signals (D+/D-) to connectors to avoid uneven trace length or crossing of the USB differential signals on the PCB.
- **PHYBoost:** enables 4 programmable levels of USB signal drive strength in downstream port transceivers. PHY-Boost will also attempt to restore USB signal integrity.

## 1.1 Configurable Features

The USB251xB/xBi hub controller provides a default configuration that may be sufficient for most applications. Strapping option pins (see [Section 3.3.1 on page 14](#)) provide additional features to enhance the default configuration. When the hub is initialized in the default configuration, the following features may be configured using the strapping options:

- Downstream non-removable ports, where the hub will automatically report as a compound device
- Downstream disabled ports
- Enabling of battery charging option on individual ports
- The USB251xB/xBi hub controllers can alternatively be configured by an external I<sup>2</sup>C EEPROM or a microcontroller as an SMBus slave device. When the hub is configured by an I<sup>2</sup>C EEPROM or over SMBus, the following configurable features are provided:
  - Support for compound devices on a port-by-port basis
  - Selectable over-current sensing and port power control on an individual or ganged basis to match the circuit board component selection
  - Customizable vendor ID, product ID, and device ID
  - Configurable USB signal drive strength
  - Configurable USB differential pair pin location
  - Configurable delay time for filtering the over-current sense inputs
  - Configurable downstream port power-on time reported to the host
  - Indication of the maximum current that the hub consumes from the USB upstream port
  - Indication of the maximum current required for the hub controller
  - Custom string descriptors (up to 31 characters):
    - Product
    - Manufacturer
    - Serial number
- Battery charging USB251xB/xBi products are fully footprint compatible with USB251x/xi/xA/xAi products:
  - Pin-compatible
  - Direct drop-in replacement
  - Use the same PCB components
  - USB-IF Compliance by Similarity for ease of use and a complete cost reduction solution
  - Product IDs, device IDs, and other register defaults may differ. See [Section 5.1 on page 19](#) for details.

**TABLE 1-1: SUMMARY OF COMPATIBILITIES BETWEEN USB251XB/XBI AND USB251X/XI/XA/XAI PRODUCTS**

Part Number	Drop-in Replacement
USB2512	USB2512B
USB2512i	USB2512Bi
USB2512A	USB2512B
USB2512Ai	USB2512Bi
USB2513	USB2513B
USB2513i	USB2513Bi
USB2514	USB2514B
USB2514i	USB2514Bi

## Conventions

Within this manual, the following abbreviations and symbols are used to improve readability.

Example	Description
<b>BIT</b>	Name of a single bit within a field
<b>FIELD.BIT</b>	Name of a single bit (BIT) in FIELD
x...y	Range from x to y, inclusive
<b>BITS[m:n]</b>	Groups of bits from m to n, inclusive
<b>PIN</b>	Pin Name
zzzzb	Binary number (value zzzz)
0xzzz	Hexadecimal number (value zzz)
zzh	Hexadecimal number (value zz)
rsvd	Reserved memory location. Must write 0, read value indeterminate
code	Instruction code, or API function or parameter
<i>Section Name</i>	Section or Document name
x	Don't care
<Parameter>	<> indicate a Parameter is optional or is only used under some conditions
{,Parameter}	Braces indicate Parameter(s) that repeat one or more times
[Parameter]	Brackets indicate a nested Parameter. This Parameter is not real and actually decodes into one or more real parameters.

# USB251xB/xBi

## 2.0 BLOCK DIAGRAM

FIGURE 2-1: USB251XB/XBI HUB FAMILY BLOCK DIAGRAM

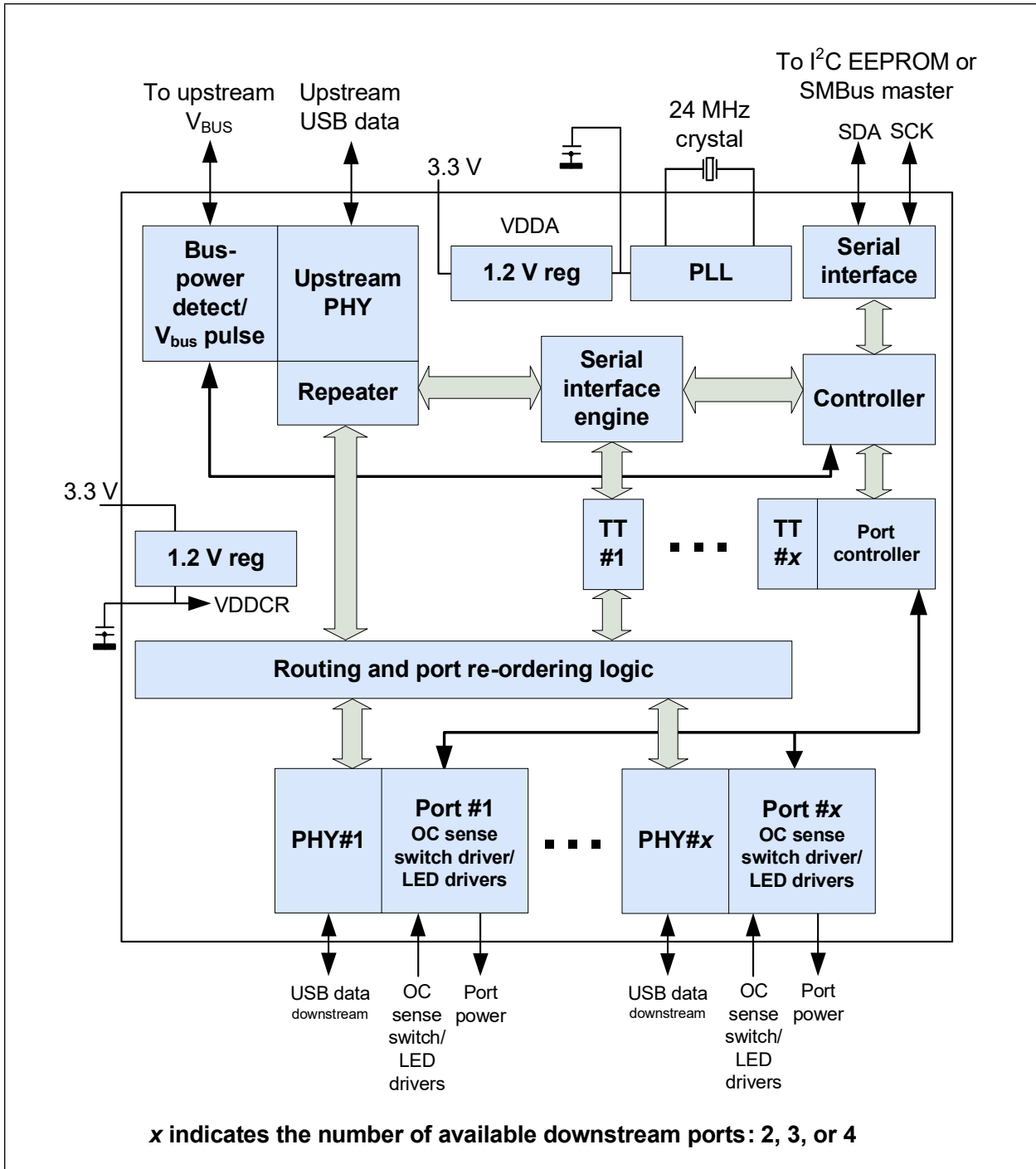

## 3.0 PIN INFORMATION

This chapter outlines the pinning configurations for each package type available, followed by a corresponding pin list organized alphabetically. The detailed pin descriptions are listed then outlined by function in [Section 3.3, "Pin Descriptions \(Grouped by Function\),"](#) on page 12.

### 3.1 Pin Configurations

The following figures detail the pinouts of the various USB251xB/xBi versions.

**FIGURE 3-1: USB2512B PIN DIAGRAM**

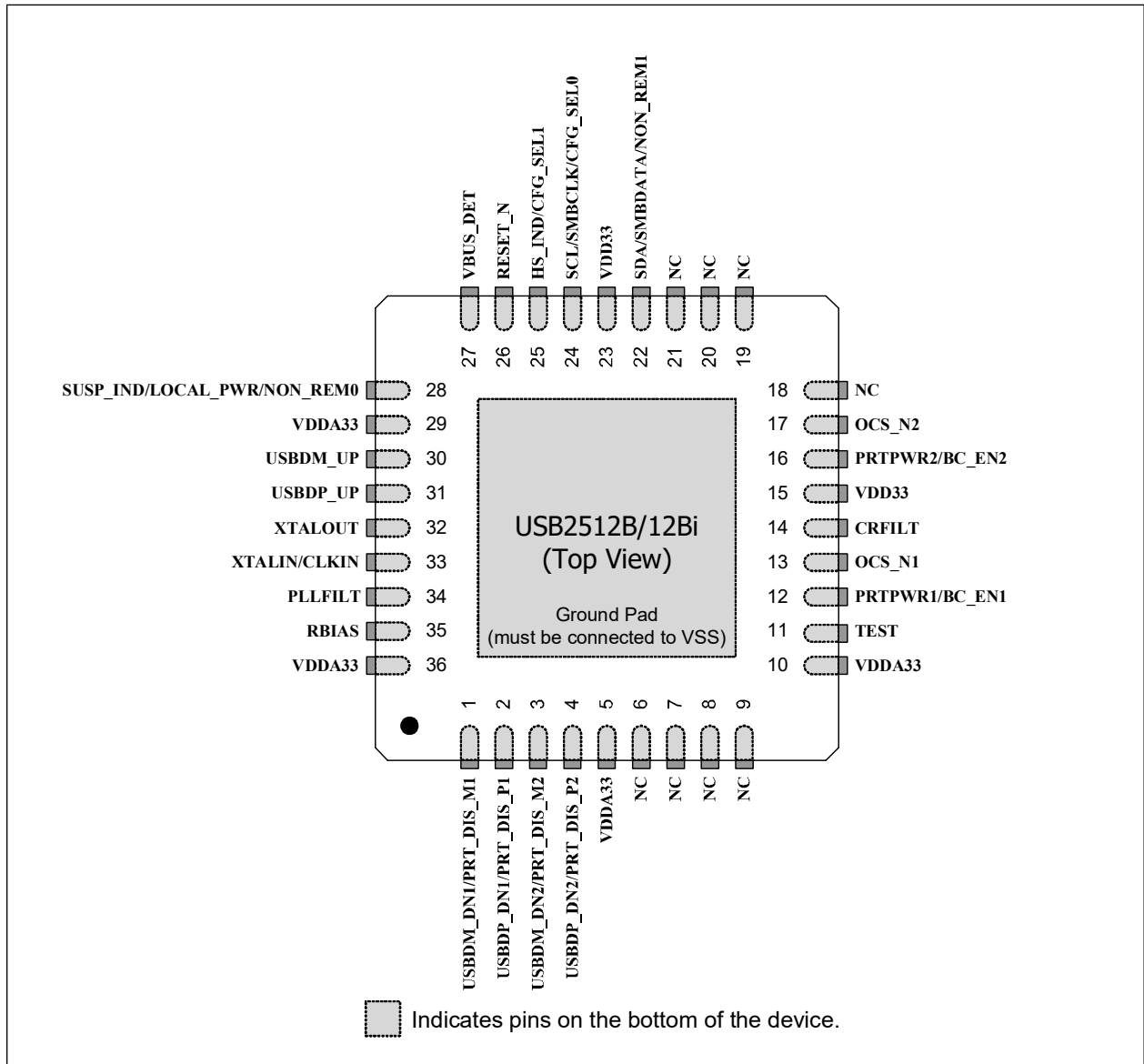

# USB251xB/xBi

FIGURE 3-2: USB2513B PIN DIAGRAM

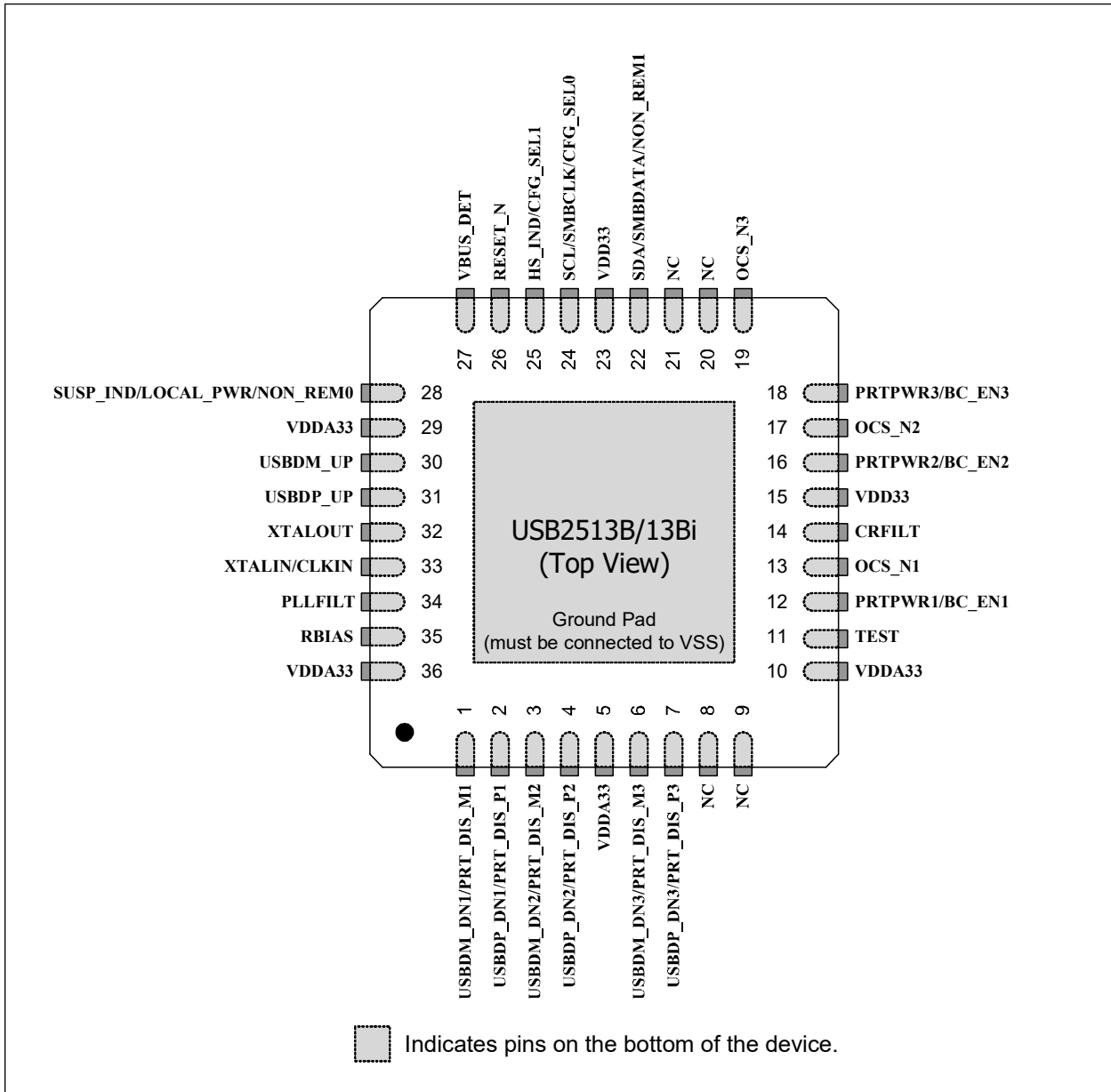

**FIGURE 3-3: USB2514B PIN DIAGRAM**

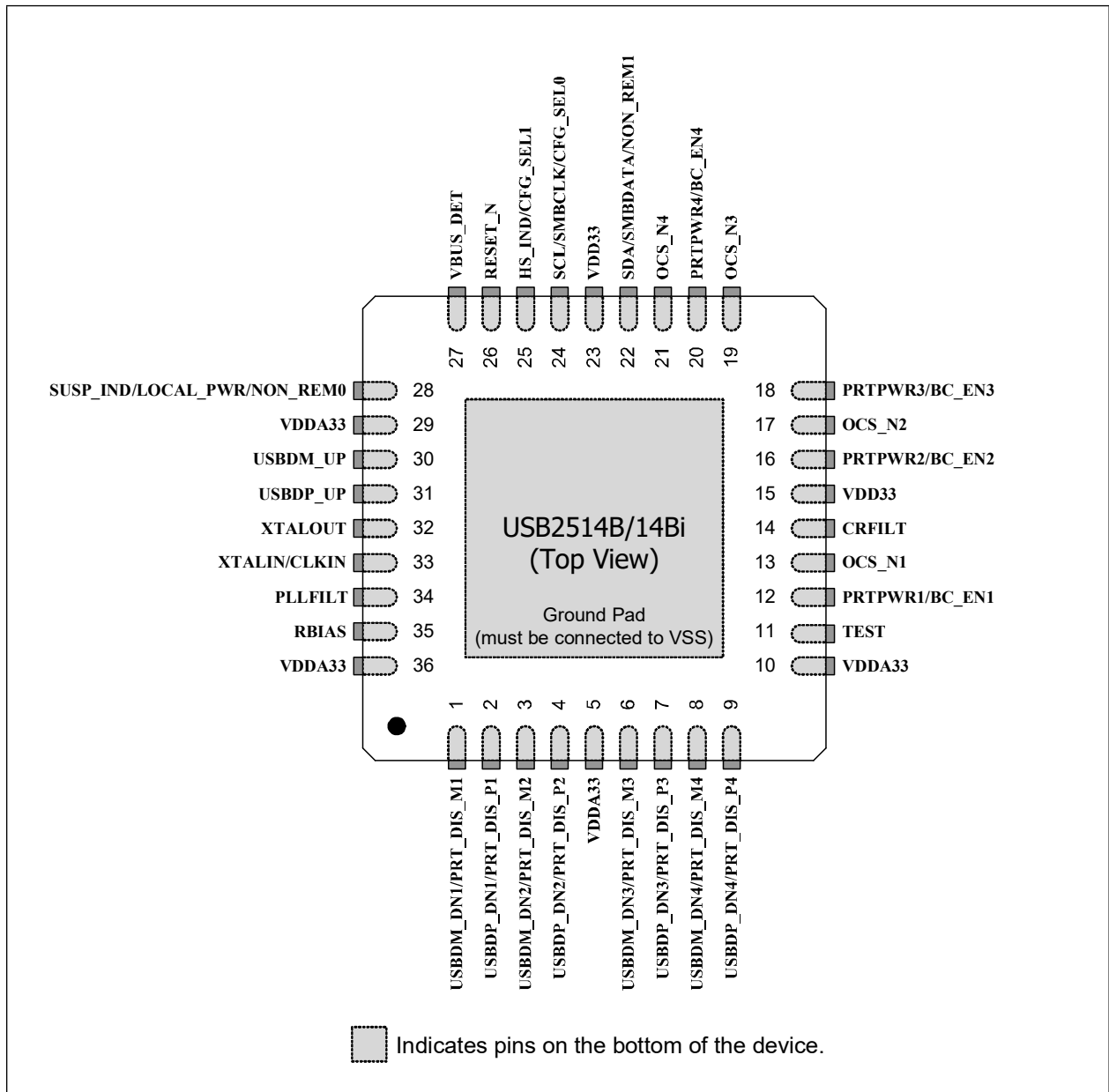

# USB251xB/xBi

## 3.2 Pin List (Alphabetical)

TABLE 3-1: USB251XB/XBI PIN LIST (ALPHABETICAL)

Symbol	Name	Pin Numbers		
		USB2512B USB2512Bi	USB2513B USB2513Bi	USB2514B USB2514Bi
BC_EN1	Battery Charging Strap Option	12		
BC_EN2		16		
BC_EN3		-	18	
BC_EN4		-		20
CFG_SEL0	Configuration Programming Selection	24		
CFG_SEL1		25		
CLKIN	External Clock Input	33		
CRFILT	Core Regulator Filter Capacitor	14		
Ground Pad (VSS)	Exposed Pad Tied to Ground (VSS)	ePad		
HS_IND	Hi-Speed Upstream Port Indicator	25		
LOCAL_PWR	Local Power Detection	28		
NC	No Connect	6	-	
NC		7	-	
NC		18	-	
NC		19	-	
NC		8		-
NC		9		-
NC		20		-
NC		21		-
NON_REM0	Non-Removable Port Strap Option	28		
NON_REM1		22		
OCS_N1	Over-Current Sense	13		
OCS_N2		17		
OCS_N3		-	19	
OCS_N4		-		21
PLLFILT	PLL Regulator Filter Capacitor	34		
PRT_DIS_M1	Downstream Port Disable Strap Option	1		
PRT_DIS_M2		3		
PRT_DIS_M3		-	6	
PRT_DIS_M4		-		8
PRT_DIS_P1	Port Disable	2		
PRT_DIS_P2		4		
PRT_DIS_P3		-	7	
PRT_DIS_P4		-		9

**TABLE 3-1: USB251XB/XBI PIN LIST (ALPHABETICAL) (CONTINUED)**

Symbol	Name	Pin Numbers			
		USB2512B USB2512Bi	USB2513B USB2513Bi	USB2514B USB2514Bi	
P RTPWR1	USB Port Power Enable	12			
P RTPWR2		16			
P RTPWR3		-	18		
P RTPWR4		-	20		
RBIAS	USB Transceiver Bias	35			
RESET_N	Reset Input	26			
SCL	Serial Clock	24			
SDA	Serial Data Signal	22			
SMBCLK	System Management Bus Clock	24			
SMBDATA	System Management Bus Data Signal	22			
SUSP_IND	Active/Suspend Status Indicator	28			
TEST	Test Pin	11			
USBDM_UP	USB Bus Data	30			
USBDP_UP		31			
USBDM_DN1	Hi-Speed USB Data	1			
USBDM_DN2		3			
USBDM_DN3		-	6		
USBDM_DN4		-	8		
USBDP_DN1		2			
USBDP_DN2		4			
USBDP_DN3		-	7		
USBDP_DN4		-	9		
VBUS_DET		Upstream VBUS Power Detection	27		
VDD33		3.3 V Digital Power	15		
VDD33	23				
VDDA33	3.3 V Analog Power	5			
VDDA33		10			
VDDA33		29			
VDDA33		36			
XTALIN		Crystal Input	33		
XTALOUT	Crystal Output	32			

# USB251xB/xBi

## 3.3 Pin Descriptions (Grouped by Function)

An *N* at the end of a signal name indicates that the active (asserted) state occurs when the signal is at a low voltage level. When the *N* is not present, the signal is asserted when it is at a high voltage level. The terms assertion and negation are used exclusively in order to avoid confusion when working with a mixture of active low and active high signals. The term assert, or assertion, indicates that a signal is active, independent of whether that level is represented by a high or low voltage. The term negate, or negation, indicates that a signal is inactive.

**TABLE 3-2: USB251XB/XBI PIN DESCRIPTIONS**

Symbol	Buffer Type	Description
<b>UPSTREAM USB 2.0 INTERFACES</b>		
<b>USBDM_UP</b> <b>USBDP_UP</b>	IO-U	USB Data: connect to the upstream USB bus data signals (host, port, or upstream hub).
<b>VBUS_DET</b>	I	Detect Upstream VBUS Power: detects the state of the upstream VBUS power. The hub monitors <b>VBUS_DET</b> to determine when to assert the internal D+ pull-up resistor: (signaling a connect event).  When designing a detachable hub, this pin should be connected to VBUS on the upstream port via a 2:1 voltage divider. Two 100 kΩ resistors are suggested.  For self-powered applications with a permanently attached host, this pin must be connected to a dedicated host control output, or connected to the 3.3 V domain that powers the host (typically <b>VDD33</b> ).
<b>DOWNSTREAM USB 2.0 INTERFACES</b>		
<b>USBDP_DN[x:1]/</b> <b>PRT_DIS_P[x:1]</b>	IO-U	Hi-Speed USB Data: connect to the downstream USB peripheral devices attached to the hub's port. To disable, use a 10 kΩ pull-up resistor to 3.3 V.
<b>USBDM_DN[x:1]/</b> <b>PRT_DIS_M[x:1]</b>		Downstream Port Disable Strap Option: when enabled by package and configuration settings (see <a href="#">Table 5-1 on page 19</a> ), this pin is sampled at <b>RESET_N</b> negation to determine if the port is disabled.  To disable a port, pull up both <b>PRT_DIS_M[x:1]</b> and <b>PRT_DIS_P[x:1]</b> pins for the corresponding port number(s). See <a href="#">Section 3.3.1, on page 14</a> for pull up details.
<b>PRT_PWR[x:1]/</b> <b>BC_EN[x:1]</b>	O12	USB Power Enable: enables power to USB peripheral devices downstream.
	IPD	Battery Charging Strap Option: when enabled by package and configuration settings (see <a href="#">Table 5-1</a> ), the pin will be sampled at <b>RESET_N</b> negation to determine if ports [x:1] support the battery charging protocol. When supporting the battery charging protocol, the hub also supports external port power controllers. The battery charging protocol enables a device to draw the currents per the USB battery charging specification. See <a href="#">Section 3.3.1, on page 14</a> for strap pin details.  1 : Battery charging feature is supported for port x 0 : Battery charging feature is not supported for port x
<b>OCS_N[x:1]</b>	IPU	Over-Current Sense: input from external current monitor indicating an over-current condition.
<b>RBIAS</b>	I-R	USB Transceiver Bias: a 12.0 kΩ (+/- 1%) resistor is attached from ground to this pin to set the transceiver's internal bias settings.

**TABLE 3-2: USB251XB/XBI PIN DESCRIPTIONS (CONTINUED)**

Symbol	Buffer Type	Description
<b>SERIAL PORT INTERFACES</b>		
SDA/ SMBDATA/ NON_REM1	I/OSD12	Serial Data Signal
		System Management Bus Signal
		<p>Non-Removable Port 1 Strap Option: when enabled by package and configuration options (see <a href="#">Table 5-1 on page 19</a>), this pin will be sampled (in conjunction with LOCAL_PWR/SUSP_IND/NON_REM0) at RESET_N negation to determine if ports [x:1] contain permanently attached (non-removable) devices:</p> <p>NON_REM[1:0] = 00 : all ports are removable            NON_REM[1:0] = 01 : port 1 is non-removable            NON_REM[1:0] = 10 : ports 1 and 2 are non-removable            NON_REM[1:0] = 11 : when available, ports 1, 2, and 3 are non-removable</p> <p>When NON_REM[1:0] is chosen such that there is a non-removable device, the hub will automatically report itself as a compound device (using the proper descriptors).</p>
RESET_N	IS	RESET Input: the system can reset the chip by driving this input low. The minimum active low pulse is 1 $\mu$ s.
SCL/ SMBCLK/ CFG_SEL0	I/OSD12	Serial Clock (SCL)
		System Management Bus Clock
		Configuration Select: the logic state of this multifunction pin is internally latched on the rising edge of RESET_N (RESET_N negation), and will determine the hub configuration method as described in <a href="#">Table 5-1</a> .
HS_IND/  CFG_SEL1	I/O12	<p>Hi-Speed Upstream Port Indicator: upstream port connection speed.</p> <p>Asserted = the hub is connected at HS            Negated = the hub is connected at FS</p> <p><b>Note:</b> When implementing an external LED on this pin, the active state is indicated above and outlined in <a href="#">Section 3.3.1.3, on page 15</a>.</p>
		Configuration Programming Select 1: the logic state of this pin is internally latched on the rising edge of RESET_N (RESET_N negation), and will determine the hub configuration method as described in <a href="#">Table 5-1</a> .
<b>MISC</b>		
XTALIN	ICLKx	Crystal Input: 24 MHz crystal.
CLKIN		This pin connects to either one terminal of the crystal or to an external 24 MHz clock when a crystal is not used.
XTALOUT	OCLKx	Crystal Output: this is the other terminal of the crystal circuit with 1.2 V p-p output and a weak (< 1mA) driving strength. When an external clock source is used to drive XTALIN/CLKIN, leave this pin unconnected, or use with appropriate caution.

# USB251xB/xBi

**TABLE 3-2: USB251XB/XBI PIN DESCRIPTIONS (CONTINUED)**

Symbol	Buffer Type	Description
SUSP_IND/  LOCAL_PWR/  NON_REM0	I/O	Active/Suspend Status LED: indicates USB state of the hub. Negated = unconfigured; or configured and in USB suspend Asserted = hub is configured and is active (i.e., not in suspend)  Local Power: detects availability of local self-power source. Low = self/local power source is NOT available (i.e., the hub gets all power from the upstream USB VBus) High = self/local power source is available  Non-Removable 0 Strap Option: when enabled by package and configuration settings (see <a href="#">Table 5-1 on page 19</a> ), this pin will be sampled (in conjunction with NON_REM[1]) at RESET_N negation to determine if ports [x:1] contain permanently attached (non-removable) devices:  <b>Note:</b> When implementing an external LED on this pin, the active state is outlined below and detailed in <a href="#">Section 3.3.1.3, on page 15</a> .  NON_REM[1:0] = 00 : all ports are removable; LED is active high NON_REM[1:0] = 01 : port 1 is non-removable; LED is active low NON_REM[1:0] = 10 : ports 1 and 2 are non-removable; LED is active high NON_REM[1:0] = 11 : (when available) ports 1, 2, and 3 are non-removable; LED is active low
TEST	IPD	Test Pin: treat as a no connect pin or connect to ground. No trace or signal should be routed or attached to this pin.
<b>POWER, GROUND, and NO CONNECTS</b>		
CRFILT		VDD Core Regulator Filter Capacitor: this pin can have up to a 0.1 $\mu$ F low-ESR capacitor to VSS, or be left unconnected.
VDD33		3.3 V Power
VDDA33		3.3 V Analog Power
PLLFILT		PLL Regulator Filter Capacitor: this pin can have up to a 0.1 $\mu$ F low-ESR capacitor to VSS, or be left unconnected.
VSS		Ground Pad/ePad: the package slug is the only VSS for the device and must be tied to ground with multiple vias.
NC		No Connect: no signal or trace should be routed or attached to all NC pins.

### 3.3.1 CONFIGURING THE STRAP PINS

If a pin's strap function is enabled thru the hub configuration selection, ([Table 5-1, "Initial Interface/Configuration Options," on page 19](#)) the strap pins must be pulled either high or low using the values provided in [Table 3-3](#). Each strap option is dependent on the pin's buffer type, as outlined in the sections that follow.

**TABLE 3-3: STRAP OPTION SUMMARY**

Strap Option	Resistor Value	Buffer Type	Notes
Non-Removable	47 - 100 k $\Omega$	I/O	
Internal Pull-Down	10 k $\Omega$	IPD	<ul style="list-style-type: none"> <li>• Only applicable to port power pins</li> <li>• Contains a built-in resistor</li> </ul>
LED	47 - 100 k $\Omega$	I/O	

### 3.3.1.1 Non-Removable

If a strap pin's buffer type is I/O, an external pull-up or pull-down must be implemented as shown in Figure 3-4. Use Strap High to set the strap option to 1 and Strap Low to set the strap option to 0. When implementing the Strap Low option, no additional components are needed (i.e., the internal pull-down provides the resistor).

**FIGURE 3-4: NON-REMOVABLE PIN STRAP EXAMPLE**

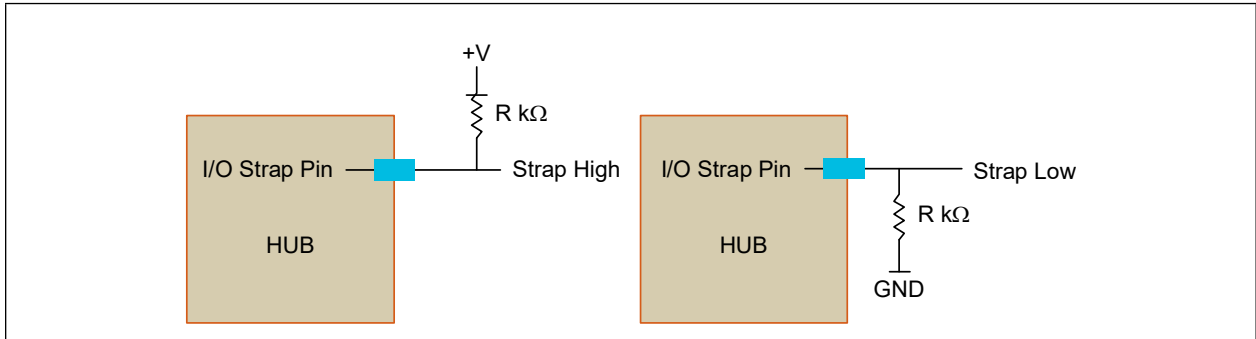

### 3.3.1.2 Internal Pull-Down (IPD)

If a strap pin's buffer type is IPD (pins **BC\_EN[x:1]**), one of the two hardware configurations outlined below must be implemented. Use the Strap High configuration to set the strap option value to 1 and Strap Low to set the strap option value to 0.

**FIGURE 3-5: PIN STRAP OPTION WITH IPD PIN EXAMPLE**

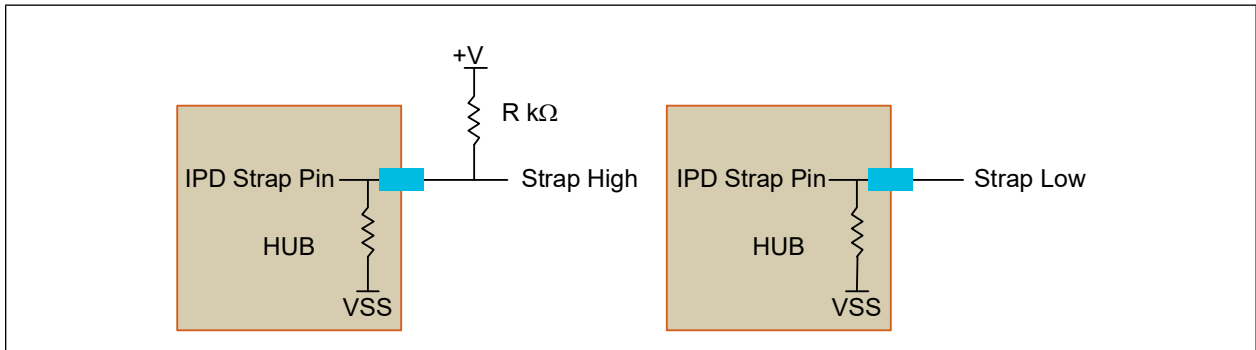

### 3.3.1.3 LED

If a strap pin's buffer type is I/O and shares functionality with an LED, the hardware configuration outlined below must be implemented. The internal logic will drive the LED appropriately (active high or low) depending on the sampled strap option. Use the Strap High configuration to set the strap option value to 1 and Strap Low to set the strap option to 0.

**FIGURE 3-6: LED PIN STRAP EXAMPLE**

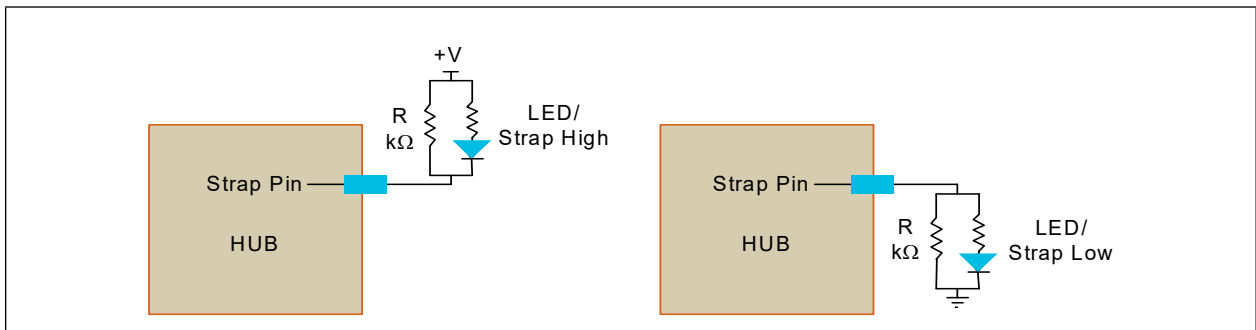

# USB251xB/xBi

---

---

## 3.4 Buffer Type Descriptions

**TABLE 3-4: BUFFER TYPE DESCRIPTIONS**

Buffer Type	Description
I	Input
I/O	Input/output
IPD	Input with internal weak pull-down resistor
IPU	Input with internal weak pull-up resistor
IS	Input with Schmitt trigger
O12	Output 12 mA
I/O12	Input/output buffer with 12 mA sink and 12 mA source
I/OSD12	Open drain with Schmitt trigger and 12 mA sink. Meets the I <sup>2</sup> C-Bus Specification [2] requirements.
ICLKx	XTAL clock input
OCLKx	XTAL clock output
I-R	RBIAS
I/O-U	Analog input/output defined in USB specification

## 4.0 BATTERY CHARGING SUPPORT

The USB251xB/xBi hub provides support for battery charging devices on a per port basis in compliance with the *USB Battery Charging Specification, Revision 1.1*. The hub can be configured to individually enable each downstream port for battery charging support either via pin strapping as illustrated in [Figure 4-1](#) or by setting the corresponding configuration bits via I<sup>2</sup>C EEPROM or SMBus ([Section 5.1 on page 19](#)).

**FIGURE 4-1: BATTERY CHARGING VIA EXTERNAL POWER SUPPLY**

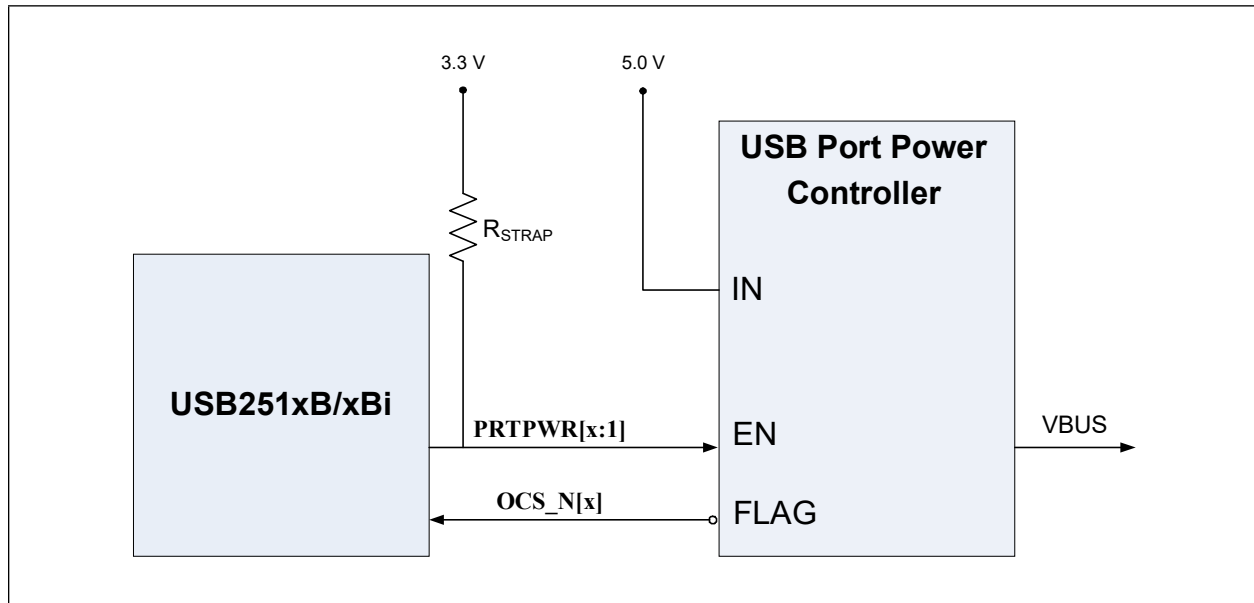

**Note:** R<sub>STRAP</sub> enables battery charging.

## 4.1 USB Battery Charging

A downstream port enabled for battery charging turns on port power as soon as the power on reset and hardware configuration process has completed. The hub does not need to be enumerated nor does VBUS\_DET need to be asserted for the port power to be enabled. These conditions allow battery charging in S3, S4, and S5 system power states as well as in the fully operational state. The *USB Battery Charging Specification* does not interfere with standard USB operation, which allows a device to perform battery charging at any time.

A port that supports battery charging must be able to support 1.5 amps of current on VBUS. Standard USB port power controllers typically only allow for 0.8 amps of current before detecting an over-current condition. Therefore, the 5 volt power supply, port power controller, or over-current protection devices must be chosen to handle the larger current demand compared to standard USB hub designs.

### 4.1.1 SPECIAL BEHAVIOR OF P RTPWR PINS

The USB251xB/xBi enables VBUS by asserting the port power (P RTPWR) as soon as the hardware configuration process has completed. If the port detects an over-current condition, P RTPWR will be turned off to protect the circuitry from overloading. If an over-current condition is detected when the hub is not enumerated, P RTPWR can only be turned on from the host or if RESET\_N is toggled. These behaviors provide battery charging even when the hub is not enumerated and protect the hub from sustained short circuit conditions. If the short circuit condition persists when the hub is plugged into a host system the user is notified that a port has an over-current condition. Otherwise P RTPWR turned on by the host system and the ports operate normally.

# USB251xB/xBi

---

## 4.2 Battery Charging Configuration

The battery charging option can be configured in one of two ways:

- When the hub is brought up in the default configuration with strapping options enabled, with the **PRT-PWR[x:1]/BC\_EN[x:1]** pins configured. See the following sections for details:
  - [Section 3.3, "Pin Descriptions \(Grouped by Function\)," on page 12](#)
  - [Section 3.3.1.2, "Internal Pull-Down \(IPD\)," on page 15](#)
- When the hub is initialized for configuration over I<sup>2</sup>C EEPROM or SMBus. Either of these interfaces can be used to configure the battery charging option.

### 4.2.1 BATTERY CHARGING ENABLED VIA I<sup>2</sup>C EEPROM OR SMBUS

Register memory map location 0xD0 is allocated for battery charging support. The Battery Charging register at location 0xD0 starting from bit 1 enables battery charging for each downstream port when asserted. Bit 1 represents port 1, bit 2 represents port 2, etc. Each port with battery charging enabled asserts the corresponding **P RTPWR[x:1]** pin.

## 5.0 INITIAL INTERFACE/CONFIGURATION OPTIONS

The hub must be configured in order to correctly function when attached to a USB host controller. The hub can be configured either internally or externally by setting the `CFG_SEL[1:0]` pins (immediately after `RESET_N` negation) as outlined in the table below.

**Note:** See Chapter 11 (Hub Specification) of the USB specification for general details regarding hub operation and functionality.

To configure the hub externally, there are two principal ways to interface to the hub: over SMBus or I<sup>2</sup>C EEPROM. The hub can be configured internally, where several default configurations are available as described in the table below. When configured internally, additional configuration is available using the strap options (listed in [Section 3.3.1 on page 14](#)).

**Note:** Strap options are not available when configuring the hub over I<sup>2</sup>C or SMBus.

**TABLE 5-1: INITIAL INTERFACE/CONFIGURATION OPTIONS**

CFG_SEL[1]	CFG_SEL[0]	Description
0	0	Default configuration: <ul style="list-style-type: none"> <li>• Strap options enabled</li> <li>• Self-powered operation enabled</li> <li>• Individual power switching</li> <li>• Individual over-current sensing</li> </ul>
0	1	The hub is configured externally over SMBus (as an SMBus slave device): <ul style="list-style-type: none"> <li>• Strap options disabled</li> <li>• All registers configured over SMBus</li> </ul>
1	0	Default configuration with the following overrides: <ul style="list-style-type: none"> <li>• Bus-powered operation</li> </ul>
1	1	The hub is configured over 2-wire I <sup>2</sup> C EEPROM: <ul style="list-style-type: none"> <li>• Strap options disabled</li> <li>• All registers configured by I<sup>2</sup>C EEPROM</li> </ul>

### 5.1 Internal Register Set (Common to I<sup>2</sup>C EEPROM and SMBus)

The register set available when configuring the hub to interface over I<sup>2</sup>C or SMBus is outlined in the table below. Each register has R/W capability, where EEPROM reset values are 0x00. Reserved registers should be written to 0 unless otherwise specified. Contents read from unavailable registers should be ignored.

Address	Register Name	Default ROM Values (Hexidecimal)		
		USB2512B/12Bi	USB2513B/13Bi	USB2514B/14Bi
00h	Vendor ID LSB	24		
01h	Vendor ID MSB	04		
02h	Product ID LSB	12	13	14
03h	Product ID MSB	25		
04h	Device ID LSB	B3		
05h	Device ID MSB	0B		

# USB251xB/xBi

Address	Register Name	Default ROM Values (Hexidecimal)		
		USB2512B/12Bi	USB2513B/13Bi	USB2514B/14Bi
06h	Configuration Data Byte 1	9B		
07h	Configuration Data Byte 2	20		
08h	Configuration Data Byte 3	02		
09h	Non-Removable Devices	00		
0Ah	Port Disable (Self)	00		
0Bh	Port Disable (Bus)	00		
0Ch	Max Power (Self)	01		
0Dh	Max Power (Bus)	32		
0Eh	Hub Controller Max Current (Self)	01		
0Fh	Hub Controller Max Current (Bus)	32		
10h	Power-on Time	32		
11h	Language ID High	00		
12h	Language ID Low	00		
13h	Manufacturer String Length	00		
14h	Product String Length	00		
15h	Serial String Length	00		
16h-53h	Manufacturer String	00		
54h-91h	Product String	00		
92h-CFh	Serial String	00		
D0h	Battery Charging Enable	00		
E0h	rsvd	00		
F5h	rsvd	00		
F6h	Boost_Up	00		
F7h	rsvd	00		
F8h	Boost_x:0	00		
F9h	rsvd	00		
FAh	Port Swap	00		
FBh	Port Map 12	00		
FCh	Port Map 34	-	00	
FD-FEh	rsvd	00		
FFh	Status/Command Note: SMBus register only	00		

## 5.1.1 REGISTER 00H: VENDOR ID (LSB)

Bit Number	Bit Name	Description
7:0	VID_LSB	Least Significant Byte of the Vendor ID: a 16-bit value that uniquely identifies the Vendor of the user device (assigned by USB-Interface Forum). Set this field using either the SMBus or I <sup>2</sup> C EEPROM interface options.

## 5.1.2 REGISTER 01H: VENDOR ID (MSB)

Bit Number	Bit Name	Description
7:0	VID_MSB	Most Significant Byte of the Vendor ID: a 16-bit value that uniquely identifies the Vendor of the user device (assigned by USB-Interface Forum). Set this field using either the SMBus or I <sup>2</sup> C EEPROM interface options.

## 5.1.3 REGISTER 02H: PRODUCT ID (LSB)

Bit Number	Bit Name	Description
7:0	PID_LSB	Least Significant Byte of the Product ID: a 16-bit value that uniquely identifies the Product ID of the user device. Set this field using either the SMBus or I <sup>2</sup> C EEPROM interface options.

## 5.1.4 REGISTER 03H: PRODUCT ID (MSB)

Bit Number	Bit Name	Description
7:0	PID_MSB	Most Significant Byte of the Product ID: a 16-bit value that uniquely identifies the Product ID of the user device. Set this field using either the SMBus or I <sup>2</sup> C EEPROM interface options.

## 5.1.5 REGISTER 04H: DEVICE ID (LSB)

Bit Number	Bit Name	Description
7:0	DID_LSB	Least Significant Byte of the Device ID: a 16-bit device release number in BCD format (assigned by OEM). Set this field using either the SMBus or I <sup>2</sup> C EEPROM interface options.

## 5.1.6 REGISTER 05H: DEVICE ID (MSB)

Bit Number	Bit Name	Description
7:0	DID_MSB	Most Significant Byte of the Device ID: a 16-bit device release number in BCD format (assigned by OEM). Set this field using either the SMBus or I <sup>2</sup> C EEPROM interface options.

# USB251xB/xBi

## 5.1.7 REGISTER 06H: CONFIG\_BYTE\_1

Bit Number	Bit Name	Description
7	SELF_BUS_PWR	<p>Self or Bus Power: selects between self- and bus-powered operation.</p> <p>The hub is either self-powered (draws less than 2 mA of upstream bus power) or bus-powered (limited to a 100 mA maximum of upstream power prior to being configured by the host controller).</p> <p>When configured as a bus-powered device, the hub consumes less than 100 mA of current prior to being configured. After configuration, the bus-powered hub, along with all associated hub circuitry, any embedded devices (if part of a compound device), and all externally available downstream ports (max 100 mA) must consume no more than 500 mA of upstream VBUS current. The current consumption is system dependent and must not violate the <i>USB 2.0 Specification</i> [1].</p> <p>When configured as a self-powered device, &lt; 1 mA of upstream VBUS current is consumed and all ports are available. Each port is capable of sourcing 500 mA of current.</p> <p>This field is set over either the SMBus or I<sup>2</sup>C EEPROM interface options.</p> <p>0 : bus-powered operation 1 : self-powered operation</p> <p>If dynamic power switching is enabled (<a href="#">Section 5.1.8</a>), this bit is ignored and <b>LOCAL_PWR</b> is used to determine if the hub is operating from self or bus power.</p>
6	rsvd	
5	HS_DISABLE	<p>Hi-Speed Disable: disables the capability to attach as either a hi- or full-speed device, forcing full-speed attachment only (i.e., no hi-speed support).</p> <p>0 : hi-/full-speed 1 : full-speed only (hi-speed disabled)</p>
4	MTT_ENABLE	<p>Multi-TT Enable: enables one transaction translator per port operation.</p> <p>Selects between a mode where only one transaction translator is available for all ports (single-TT), or each port gets a dedicated transaction translator (multi-TT).</p> <p>0 : single TT for all ports 1 : multi-TT (one TT per port)</p>
3	EOP_DISABLE	<p>EOP Disable: disables End Of Packet (EOP) generation at End Of Frame Time #1 (EOF1) when in full-speed mode.</p> <p>During full-speed operation only, the hub can send EOP when no downstream traffic is detected at EOF1. See the <i>USB 2.0 Specification, Section 11.3.1</i> for details.</p> <p>0 : EOP generation is normal 1 : EOP generation is disabled</p>
2:1	CURRENT_SNS	<p>Over-Current Sense: selects current sensing on all ports (ganged); a port-by-port basis (individual); or none (for bus-powered hubs only). The ability to support current sensing on a ganged or port-by-port basis is hardware implementation dependent.</p> <p>00 : ganged sensing 01 : individual sensing 1x : over-current sensing not supported (use with bus-powered configurations)</p>
0	PORT_PWR	<p>Port Power Switching: enables power switching on all ports (ganged) or a port-by-port basis (individual). The ability to support power enabling on a ganged or port-by-port basis is hardware implementation dependent.</p> <p>0 : ganged switching 1 : individual switching</p>

## 5.1.8 REGISTER 07H: CONFIGURATION DATA BYTE 2

Bit Number	Bit Name	Description
7	DYNAMIC	<p>Dynamic Power Enable: controls the ability of the hub to automatically change from self-powered to bus-powered operation if the local power source is removed or unavailable. It can also go from bus-powered to self-powered operation if the local power source is restored.</p> <p>When dynamic power switching is enabled, the hub detects the availability of a local power source by monitoring <b>LOCAL_PWR</b>. If the hub detects a change in power source availability, the hub immediately disconnects and removes power from all downstream devices. It also disconnects the upstream port. The hub will then re-attach to the upstream port as either a bus-powered hub (if local power is unavailable) or a self-powered hub (if local power is available).</p> <p>0 : no dynamic auto-switching 1 : dynamic auto-switching capable</p>
6	rsvd	
5:4	OC_TIMER	<p>Over Current Timer Delay:</p> <p>00 : 0.1 ms 01 : 4.0 ms 10 : 8.0 ms 11 : 16.0 ms</p>
3	COMPOUND	<p>Compound Device: indicates the hub is part of a compound device (see the <i>USB Specification</i> for definition). The applicable port(s) must also be defined as having a non-removable device.</p> <p><b>Note:</b> When configured via strapping options, declaring a port as non-removable automatically causes the hub controller to report that it is part of a compound device.</p> <p>0 : no 1 : yes, the hub is part of a compound device</p>
2:0	rsvd	

## 5.1.9 REGISTER 08H: CONFIGURATION DATA BYTE 3

Bit Number	Bit Name	Description
7:4	rsvd	
3	PRTMAP_EN	<p>Port Mapping Enable: selects the method used by the hub to assign port numbers and disable ports.</p> <p>0 : standard mode 1 : port mapping mode</p>
2:1	rsvd	
0	STRING_EN	<p>Enables String Descriptor Support</p> <p>0 : string support disabled 1 : string support enabled</p>

# USB251xB/xBi

## 5.1.10 REGISTER 09H: NON-REMOVABLE DEVICE

Bit Number	Bit Name	Description
7:0	NR_DEVICE	<p>Non-Removable Device: indicates which port has a non-removable device.</p> <p>0 : port is removable 1 : port is non-removable</p> <p>Bit 7 : rsvd Bit 6 : rsvd Bit 5 : rsvd Bit 4 : controls port 4 Bit 3 : controls port 3 Bit 2 : controls port 2 Bit 1 : controls port 1 Bit 0 : rsvd</p> <p><b>Note:</b> The device must provide its own descriptor data.</p> <p>When using the default configuration, the <b>NON_REM[1:0]</b> pins will designate the appropriate ports as being non-removable.</p>

## 5.1.11 REGISTER 0AH: PORT DISABLE FOR SELF-POWERED OPERATION

Bit Number	Bit Name	Description
7:0	PORT_DIS_SP	<p>Port Disable Self-Powered: disables one or more ports.</p> <p>0 = port is available 1 = port is disabled</p> <p>Bit 7 : rsvd Bit 6 : rsvd Bit 5 : rsvd Bit 4 : controls port 4 Bit 3 : controls port 3 Bit 2 : controls port 2 Bit 1 : controls port 1 Bit 0 : rsvd</p> <p>During self-powered operation when mapping mode is disabled (<b>PRTMAP_EN</b> = 0), this register selects the ports that will be permanently disabled. These ports are then unavailable and cannot be enabled or enumerated by a host controller. The ports can be disabled in any order, where the internal logic will automatically report the correct number of enabled ports to the USB host. The active ports will be reordered in order to ensure proper function.</p> <p>When using the default configuration, <b>PRT_DIS_P[x:1]</b> and <b>PRT_DIS_M[x:1]</b> pins disable the appropriate ports.</p>

## 5.1.12 REGISTER 0BH: PORT DISABLE FOR BUS-POWERED OPERATION

Bit Number	Bit Name	Description
7:0	PORT_DIS_BP	<p>Port Disable Bus-Powered: disables one or more ports.</p> <p>0 = port is available 1 = port is disabled</p> <p>Bit 7 : rsvd Bit 6 : rsvd Bit 5 : rsvd Bit 4 : controls port 4 Bit 3 : controls port 3 Bit 2 : controls port 2 Bit 1 : controls port 1 Bit 0 : rsvd</p> <p>During self-powered operation when mapping mode is disabled (<b>PRTMAP_EN</b> = 0), this selects the ports which will be permanently disabled. These ports are then unavailable and cannot be enabled or enumerated by a host controller. The ports can be disabled in any order, where the internal logic will automatically report the correct number of enabled ports to the USB host. The active ports will be reordered in order to ensure proper function.</p> <p>When using the internal default option, the <b>PRT_DIS_P[x:1]</b> and <b>PRT_DIS_M[x:1]</b> pins disable the appropriate ports.</p>

## 5.1.13 REGISTER 0CH: MAX POWER FOR SELF-POWERED OPERATION

Bit Number	Bit Name	Description
7:0	MAX_PWR_SP	<p>Max Power Self-Powered: the value in 2 mA increments that the hub consumes from an upstream port (VBUS) when operating as a self-powered hub. This value includes the hub silicon along with the combined power consumption (from VBUS) of all associated circuitry on the board. This value also includes the power consumption of a permanently attached peripheral if the hub is configured as a compound device. The embedded peripheral reports 0 mA in its descriptors.</p> <p><b>Note:</b> The <i>USB 2.0 Specification</i> does not permit this value to exceed 100 mA</p>

## 5.1.14 REGISTER 0DH: MAX POWER FOR BUS-POWERED OPERATION

Bit Number	Bit Name	Description
7:0	MAX_PWR_BP	<p>Max Power Bus-Powered: the value in 2 mA increments that the hub consumes from an upstream port (VBUS) when operating as a bus-powered hub. This value includes the hub silicon along with the combined power consumption (from VBUS) of all associated circuitry on the board. This value also includes the power consumption of a permanently attached peripheral if the hub is configured as a compound device. The embedded peripheral reports 0 mA in its descriptors.</p>

# USB251xB/xBi

---

---

## 5.1.15 REGISTER 0EH: HUB CONTROLLER MAX CURRENT FOR SELF-POWERED OPERATION

Bit Number	Bit Name	Description
7:0	HC_MAX_C_SP	Hub Controller Max Current Self-Powered: the value in 2 mA increments that the hub consumes from an upstream port (VBUS) when operating as a self-powered hub. This value includes the hub silicon along with the combined power consumption (from VBUS) of all associated circuitry on the board. This value does NOT include the power consumption of a permanently attached peripheral if the hub is configured as a compound device.  <b>Note:</b> The <i>USB 2.0 Specification</i> does not permit this value to exceed 100 mA  A value of 50 (decimal) indicates 100 mA, which is the default value.

## 5.1.16 REGISTER 0FH: HUB CONTROLLER MAX CURRENT FOR BUS-POWERED OPERATION

Bit Number	Bit Name	Description
7:0	HC_MAX_C_BP	Hub Controller Max Current Bus-Powered: the value in 2 mA increments that the hub consumes from an upstream port (VBUS) when operating as a bus-powered hub. This value will include the hub silicon along with the combined power consumption (from VBUS) of all associated circuitry on the board.  <b>Note:</b> This value will not include the power consumption of a permanently attached peripheral if the hub is configured as a compound device.  A value of 50 (decimal) would indicate 100 mA, which is the default value.

## 5.1.17 REGISTER 10H: POWER-ON TIME

Bit Number	Bit Name	Description
7:0	POWER_ON_TIME	Power-On Time: the length of time that it takes (in 2 ms intervals) from the time the host initiated the power-on sequence on a port until the port has adequate power.

## 5.1.18 REGISTER 11H: LANGUAGE ID HIGH

Bit Number	Bit Name	Description
7:0	LANG_ID_H	USB Language ID: upper 8 bits of a 16-bit ID field

## 5.1.19 REGISTER 12H: LANGUAGE ID LOW

Bit Number	Bit Name	Description
7:0	LANG_ID_L	USB Language ID: lower 8 bits of a 16-bit ID field

## 5.1.20 REGISTER 13H: MANUFACTURER STRING LENGTH

Bit Number	Bit Name	Description
7:0	MFR_STR_LEN	Manufacturer String Length: with a maximum string length of 31 characters (when supported).

## 5.1.21 REGISTER 14H: PRODUCT STRING LENGTH

Bit Number	Bit Name	Description
7:0	PRD_STR_LEN	Product String Length: with a maximum string length of 31 characters (when supported).

## 5.1.22 REGISTER 15H: SERIAL STRING LENGTH

Bit Number	Bit Name	Description
7:0	SER_STR_LEN	Serial String Length: with a maximum string length of 31 characters (when supported).

## 5.1.23 REGISTER 16H-53H: MANUFACTURER STRING

Bit Number	Bit Name	Description
7:0	MFR_STR	<p>Manufacturer String: UNICODE UTF-16LE per <i>USB 2.0 Specification</i>: with a maximum string length of 31 characters (when supported).</p> <p><b>Note:</b> The string consists of individual 16-bit UNICODE UTF-16LE characters. The characters will be stored starting with the LSB at the least significant address and the MSB at the next 8-bit location. (Subsequent characters must be stored in sequential contiguous addresses in the same LSB, MSB manner.)</p> <p><b>Warning:</b> Close attention to the byte order of the selected programming tool should be monitored.</p>

## 5.1.24 REGISTER 54H-91H: PRODUCT STRING

Bit Number	Bit Name	Description
7:0	PRD_STR	<p>Product String: UNICODE UTF-16LE per <i>USB 2.0 Specification</i></p> <p>When supported, the maximum string length is 31 characters (62 bytes).</p> <p><b>Note:</b> The string consists of individual 16-bit UNICODE UTF-16LE characters. The characters will be stored starting with the LSB at the least significant address and the MSB at the next 8-bit location. (Subsequent characters must be stored in sequential contiguous address in the same LSB, MSB manner.)</p> <p><b>Warning:</b> Close attention to the byte order of the selected programming tool should be monitored.</p>

## 5.1.25 REGISTER 92H-CFH: SERIAL STRING

Bit Number	Bit Name	Description
7:0	SER_STR	<p>Serial String: UNICODE UTF-16LE per USB 2.0 specification</p> <p>When supported, the maximum string length is 31 characters (62 bytes).</p> <p><b>Note:</b> The string consists of individual 16-bit UNICODE UTF-16LE characters. The characters will be stored starting with the LSB at the least significant address and the MSB at the next 8-bit location. (Subsequent characters must be stored in sequential contiguous address in the same LSB, MSB manner.)</p> <p><b>Warning:</b> Close attention to the byte order of the selected programming tool should be monitored.</p>

# USB251xB/xBi

---

---

## 5.1.26 REGISTER D0H: BATTERY CHARGING ENABLE

Bit Number	Bit Name	Description
7:0	BC_EN	Battery Charging Enable: enables the battery charging feature for the corresponding port. 0 : battery charging support is not enabled 1 : battery charging support is enabled  Bit 7 : rsvd Bit 6 : rsvd Bit 5 : rsvd Bit 4 : controls port 4 Bit 3 : controls port 3 Bit 2 : controls port 2 Bit 1 : controls port 1 Bit 0 : rsvd

## 5.1.27 REGISTER F6H: BOOST\_UP

Bit Number	Bit Name	Description
7:2	rsvd	
1:0	BOOST_IOUT	USB electrical signaling drive strength boost bit for the upstream port. 00 : normal electrical drive strength - no boost 01 : elevated electrical drive strength - low (~ 4% boost) 10 : elevated electrical drive strength - medium (~ 8% boost) 11 : elevated electrical drive strength - high (~12% boost)  <b>Note:</b> Boost could result in non-USB compliant parameters. Therefore, a value of 00 should be implemented unless specific implementation issues require additional signal boosting to correct for degraded USB signalling levels.

## 5.1.28 REGISTER F8H: BOOST\_4:0

Bit Number	Bit Name	Description
7:6	BOOST_IOUT_4	USB electrical signaling drive strength boost bit for downstream port 4. 00 : normal electrical drive strength - no boost 01 : elevated electrical drive strength - low (~4% boost) 10 : elevated electrical drive strength - medium (~ 8% boost) 11 : elevated electrical drive strength - high (~12% boost)
5:4	BOOST_IOUT_3	USB electrical signaling drive strength boost bit for downstream port 3. 00 : normal electrical drive strength - no boost 01 : elevated electrical drive strength - low (~4% boost) 10 : elevated electrical drive strength - medium (~ 8% boost) 11 : elevated electrical drive strength - high (~12% boost)
3:2	BOOST_IOUT_2	USB electrical signaling drive strength boost bit for downstream port 2. 00 : normal electrical drive strength - no boost 01 : elevated electrical drive strength - low (~4% boost) 10 : elevated electrical drive strength - medium (~ 8% boost) 11 : elevated electrical drive strength - high (~12% boost)
1:0	BOOST_IOUT_1	USB electrical signaling drive strength boost bit for downstream port 1. 00 : normal electrical drive strength - no boost 01 : elevated electrical drive strength - low (~4% boost) 10 : elevated electrical drive strength - medium (~ 8% boost) 11 : elevated electrical drive strength - high (~12% boost)

**Note:** Boost could result in non-USB compliant parameters. Therefore, a value of 00 should be implemented unless specific implementation issues require additional signal boosting to correct for degraded USB signaling levels.

## 5.1.29 REGISTER FAH: PORT SWAP

Bit Number	Bit Name	Description
7:0	PRTSP	Port Swap: swaps the upstream USBDP/USBDM pins (USB <sub>DP_UP</sub> and USB <sub>DM_UP</sub> ) and the downstream USBDP/USBDM pins (USB <sub>DP_DN[x:1]</sub> and USB <sub>DM_DN[x:1]</sub> ) for ease of board routing to devices and connectors. 0 : USB D+ functionality is associated with the DP pin and D- functionality is associated with the DM pin. 1 : USB D+ functionality is associated with the DM pin and D- functionality is associated with the DP pin. Bit 7 : rsvd Bit 6 : rsvd Bit 5 : rsvd Bit 4 : controls port 4 Bit 3 : controls port 3 Bit 2 : controls port 2 Bit 1 : controls port 1 Bit 0 : when set to 1, the upstream port DP/DM is swapped.

# USB251xB/xBi

## 5.1.30 REGISTER FBH: PORTMAP 12

Bit Number	Bit Name	Description																										
7:0	PRTR12	<p>PortMap Register for Ports 1 and 2: When a hub is enumerated by a USB host controller, the hub is only permitted to report how many ports it has; the hub is not permitted to select a numerical range or assignment. The host controller will number the downstream ports of the hub starting with the number 1, up to the number of ports that the hub reports having.</p> <p>The host's port number is called the Logical Port Number and the physical port on the hub is the Physical Port Number. When mapping mode is enabled (see <b>PRTMAP_EN</b>, <a href="#">Section 5.1.9 on page 23</a>) the hub's downstream port numbers can be mapped to different logical port numbers (assigned by the host).</p> <p><b>Note:</b> Contiguous logical port numbers must be implemented, starting from number 1 up to the maximum number of enabled ports. This ensures that the hub's ports are numbered in accordance with the way a host will communicate with the ports.</p>																										
		<table border="1"> <tbody> <tr> <td rowspan="7">Bit [7:4]</td> <td>0000</td> <td>Physical port 2 is disabled</td> </tr> <tr> <td>0001</td> <td>Physical port 2 is mapped to logical port 1</td> </tr> <tr> <td>0010</td> <td>Physical port 2 is mapped to logical port 2</td> </tr> <tr> <td>0011</td> <td>Physical port 2 is mapped to logical port 3</td> </tr> <tr> <td>0100</td> <td>Physical port 2 is mapped to logical port 4</td> </tr> <tr> <td>1000 to 1111</td> <td>rsvd, will default to 0000 value</td> </tr> <tr> <td rowspan="7">Bit [3:0]</td> <td>0000</td> <td>Physical port 1 is disabled</td> </tr> <tr> <td>0001</td> <td>Physical port 1 is mapped to logical port 1</td> </tr> <tr> <td>0010</td> <td>Physical port 1 is mapped to logical port 2</td> </tr> <tr> <td>0011</td> <td>Physical port 1 is mapped to logical port 3</td> </tr> <tr> <td>0100</td> <td>Physical port 1 is mapped to logical port 4</td> </tr> <tr> <td>1000 to 1111</td> <td>rsvd, will default to 0000 value</td> </tr> </tbody> </table>	Bit [7:4]	0000	Physical port 2 is disabled	0001	Physical port 2 is mapped to logical port 1	0010	Physical port 2 is mapped to logical port 2	0011	Physical port 2 is mapped to logical port 3	0100	Physical port 2 is mapped to logical port 4	1000 to 1111	rsvd, will default to 0000 value	Bit [3:0]	0000	Physical port 1 is disabled	0001	Physical port 1 is mapped to logical port 1	0010	Physical port 1 is mapped to logical port 2	0011	Physical port 1 is mapped to logical port 3	0100	Physical port 1 is mapped to logical port 4	1000 to 1111	rsvd, will default to 0000 value
Bit [7:4]	0000	Physical port 2 is disabled																										
	0001	Physical port 2 is mapped to logical port 1																										
	0010	Physical port 2 is mapped to logical port 2																										
	0011	Physical port 2 is mapped to logical port 3																										
	0100	Physical port 2 is mapped to logical port 4																										
	1000 to 1111	rsvd, will default to 0000 value																										
	Bit [3:0]	0000	Physical port 1 is disabled																									
0001		Physical port 1 is mapped to logical port 1																										
0010		Physical port 1 is mapped to logical port 2																										
0011		Physical port 1 is mapped to logical port 3																										
0100		Physical port 1 is mapped to logical port 4																										
1000 to 1111		rsvd, will default to 0000 value																										

## 5.1.31 REGISTER FCH: PORTMAP 34

Bit Number	Bit Name	Description																																				
7:0	PRTR34	<p>PortMap Register for Ports 3 and 4: When a hub is enumerated by a USB host controller, the hub is only permitted to report how many ports it has; the hub is not permitted to select a numerical range or assignment. The host controller will number the downstream ports of the hub starting with the number 1, up to the number of ports that the hub reports having.</p> <p>The host's port number is called the Logical Port Number and the physical port on the hub is the Physical Port Number. When mapping mode is enabled (see <b>PRTMAP_EN</b>, <a href="#">Section 5.1.9 on page 23</a>) the hub's downstream port numbers can be mapped to different logical port numbers (assigned by the host).</p> <p><b>Note:</b> Contiguous logical port numbers must be implemented, starting from number 1 up to the maximum number of enabled ports. This ensures that the hub's ports are numbered in accordance with the way a host will communicate with the ports.</p> <table border="1"> <tbody> <tr> <td>Bit [7:4]</td> <td>0000</td> <td>Physical port 4 is disabled</td> </tr> <tr> <td></td> <td>0001</td> <td>Physical port 4 is mapped to logical port 1</td> </tr> <tr> <td></td> <td>0010</td> <td>Physical port 4 is mapped to logical port 2</td> </tr> <tr> <td></td> <td>0011</td> <td>Physical port 4 is mapped to logical port 3</td> </tr> <tr> <td></td> <td>0100</td> <td>Physical port 4 is mapped to logical port 4</td> </tr> <tr> <td></td> <td>1000 to 1111</td> <td>rsvd, will default to 0000 value</td> </tr> <tr> <td>Bit [3:0]</td> <td>0000</td> <td>Physical port 3 is disabled</td> </tr> <tr> <td></td> <td>0001</td> <td>Physical port 3 is mapped to logical port 1</td> </tr> <tr> <td></td> <td>0010</td> <td>Physical port 3 is mapped to logical port 2</td> </tr> <tr> <td></td> <td>0011</td> <td>Physical port 3 is mapped to logical port 3</td> </tr> <tr> <td></td> <td>0100</td> <td>Physical port 3 is mapped to logical port 4</td> </tr> <tr> <td></td> <td>1000 to 1111</td> <td>rsvd, will default to 0000 value</td> </tr> </tbody> </table>	Bit [7:4]	0000	Physical port 4 is disabled		0001	Physical port 4 is mapped to logical port 1		0010	Physical port 4 is mapped to logical port 2		0011	Physical port 4 is mapped to logical port 3		0100	Physical port 4 is mapped to logical port 4		1000 to 1111	rsvd, will default to 0000 value	Bit [3:0]	0000	Physical port 3 is disabled		0001	Physical port 3 is mapped to logical port 1		0010	Physical port 3 is mapped to logical port 2		0011	Physical port 3 is mapped to logical port 3		0100	Physical port 3 is mapped to logical port 4		1000 to 1111	rsvd, will default to 0000 value
Bit [7:4]	0000	Physical port 4 is disabled																																				
	0001	Physical port 4 is mapped to logical port 1																																				
	0010	Physical port 4 is mapped to logical port 2																																				
	0011	Physical port 4 is mapped to logical port 3																																				
	0100	Physical port 4 is mapped to logical port 4																																				
	1000 to 1111	rsvd, will default to 0000 value																																				
Bit [3:0]	0000	Physical port 3 is disabled																																				
	0001	Physical port 3 is mapped to logical port 1																																				
	0010	Physical port 3 is mapped to logical port 2																																				
	0011	Physical port 3 is mapped to logical port 3																																				
	0100	Physical port 3 is mapped to logical port 4																																				
	1000 to 1111	rsvd, will default to 0000 value																																				

# USB251xB/xBi

## 5.1.32 REGISTER FFH: STATUS/COMMAND

Bit Number	Bit Name	Description
7:3	rsvd	
2	INTF_PW_DN	SMBus Interface Power Down: 0 : interface is active 1 : interface power down after ACK has completed
1	RESET	Reset the SMBus interface and internal memory back to <b>RESET_N</b> assertion default settings. 0 : normal run/idle state 1 : force a reset of registers to their default state
0	USB_ATTACH	USB Attach (and write protect) 0 : SMBus slave interface is active 1 : the hub will signal a USB attach event to an upstream device, and the internal memory (address range 0x00-0xFE) is write-protected to prevent unintentional data corruption.

## 5.2 I<sup>2</sup>C EEPROM

The hub can be configured via a 2-wire (I<sup>2</sup>C) EEPROM (256x8). See [Table 5-1](#) for details on enabling the I<sup>2</sup>C EEPROM interface. The I<sup>2</sup>C EEPROM interface implements a subset of the *I<sup>2</sup>C Master Specification* (refer to the Philips Semiconductor Standard I<sup>2</sup>C-Bus Specification I<sup>2</sup>C protocol for details). The hub's interface is designed to attach to a single dedicated I<sup>2</sup>C EEPROM which conforms to the Standard-mode I<sup>2</sup>C specification (100 kbit/s transfer rate and 7-bit addressing) for protocol and electrical compatibility. The I<sup>2</sup>C EEPROM shares the same pins as the SMBus interface, therefore the SMBus interface is not available when the I<sup>2</sup>C EEPROM interface has been enabled (and vice versa).

The hub acts as the master and generates the serial clock SCL, controls the bus access (determines which device acts as the transmitter and which device acts as the receiver), and generates the START and STOP conditions. The hub will read the external EEPROM for configuration data and then attach to the upstream USB host.

**Note:** If no external EEPROM is present, the hub will write 0 to all configuration registers.

The hub does not have the capacity to write to the external EEPROM. The hub only has the capability to read from an external EEPROM. The external EEPROM will be read (even if it is blank), and the hub will be configured with the values that are read. Any values read for unsupported registers will not be retained (i.e., they will remain as the default values). Reserved registers should be set to 0 unless otherwise specified. EEPROM reset values are 0x00. Contents read from unavailable registers should be ignored.

### 5.2.1 I<sup>2</sup>C SLAVE ADDRESS

The 7-bit slave address is 1010000b.

**Note:** 10-bit addressing is not supported.

### 5.2.2 PROTOCOL IMPLEMENTATION

The hub will only access an EEPROM using the sequential read protocol as outlined in Chapter 8 of *MicroChip 24AA02/24LC02B* [4].

### 5.2.3 PULL-UP RESISTOR

The circuit board designer is required to place external pull-up resistors (10 kΩ recommended) on the **SDA/SMBDATA** and **SCL/SMBCLK/CFG\_SEL[0]** lines (per *SMBus 1.0 Specification* [3], and EEPROM manufacturer guidelines) to **VDD33** in order to assure proper operation.

## 5.2.4 IN-CIRCUIT EEPROM PROGRAMMING

The EEPROM can be programmed via automatic test equipment (ATE) by pulling **RESET\_N** low (which tri-states the hub's EEPROM interface and allows an external source to program the EEPROM).

**Note:** The Hub does not have the capacity to write, or "Program," an external EEPROM. The Hub only has the capability to read external EEPROMs. The external EEPROM will be read (even if it is blank or non-populated), and the Hub will be "configured" with the values that are read.

## 5.3 SMBus

The Microchip hub can be configured by an external processor via an SMBus interface (see [Table 5-1](#) for details on enabling the SMBus interface). The SMBus interface shares the same pins as the EEPROM interface, and therefore the hub no longer supports the I<sup>2</sup>C EEPROM interface when the SMBus interface has been enabled. The hub waits indefinitely for the SMBus code load to complete and only appears as a newly connected device on USB after the code load is complete.

The hub's SMBus acts as a slave-only SMBus device. The implementation only supports block write ([Section 5.3.2.1](#)) and block read ([Section 5.3.2.2](#)) protocols, where the available registers are outlined in [Section 5.1 on page 19](#). Reference the *System Management Bus Specification* [3] for additional information.

### 5.3.1 SMBUS SLAVE ADDRESS

The 7-bit slave address is 0101100b. The hub will not respond to the general call address of 0000000b.

### 5.3.2 PROTOCOL IMPLEMENTATION

Typical block write and block read protocols are shown in figures [5-2](#) and [5-3](#). Register accesses are performed using 7-bit slave addressing, an 8-bit register address field, and an 8-bit data field. The shading shown in the figures during a read or write indicates the hub is driving data on the **SMBDATA** line; otherwise, host data is on the **SDA/SMBDATA** line.

The SMBus slave address assigned to the hub (0101100b) allows it to be identified on the SMBus. The register address field is the internal address of the register to be accessed. The register data field is the data that the host is attempting to write to the register or the contents of the register that the host is attempting to read.

**Note:** Data bytes are transferred MSB first.

# USB251xB/xBi

## 5.3.2.1 Block Write/Read

The block write begins with a slave address and a write condition. After the command code, the host issues a byte count which describes how many more bytes will follow in the message. If a slave had 20 bytes to send, the first byte would be the number 20 (14h), followed by the 20 bytes of data. The byte count may not be zero. A block write or read allows a transfer maximum of 32 data bytes.

**Note:** For the following SMBus tables:

Denotes Master-to-Slave    
  Denotes Slave-to-Master

**TABLE 5-2: BLOCK WRITE**

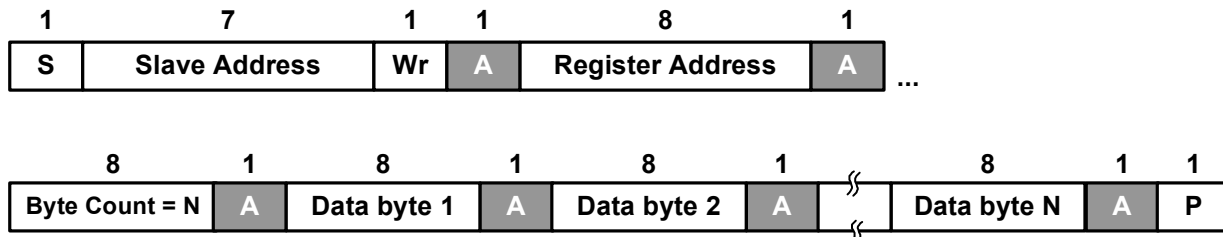

## 5.3.2.2 Block Read

A block read differs from a block write in that the repeated start condition exists to satisfy the I<sup>2</sup>C specification's requirement for a change in the transfer direction.

**TABLE 5-3: BLOCK READ**

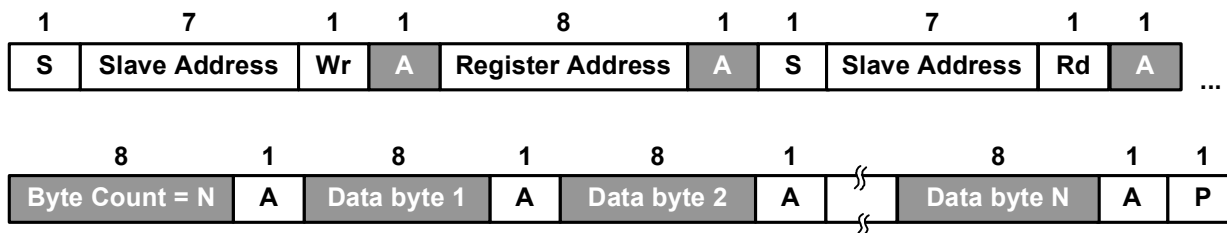

## 5.3.2.3 Invalid Protocol Response Behavior

Note that any attempt to update registers with an invalid protocol will not be updated. The only valid protocols are write block and read block (described above), where the hub only responds to the 7-bit hardware selected slave address (0101100b). Also, the only valid registers for the hub are outlined in [Section 5.1 on page 19](#). Attempts to access any other registers will return no response.

## 5.3.3 SLAVE DEVICE TIMEOUT

Devices in a transfer can abort the transfer in progress and release the bus when any single clock low interval exceeds 25 ms ( $T_{TIMEOUT, MIN}$ ). The master must detect this condition and generate a stop condition within or after the transfer of the interrupted data byte. Slave devices must reset their communication and be able to receive a new START condition no later than 35 ms ( $T_{TIMEOUT, MAX}$ ).

**Note:** Some simple devices do not contain a clock low drive circuit; this simple kind of device typically resets its communications port after a start or stop condition. The slave device timeout must be implemented.

## 5.3.4 STRETCHING THE SCLK SIGNAL

The hub supports stretching of the SCLK by other devices on the SMBus. However, the hub does not stretch the SCLK.

## 5.3.5 SMBUS TIMING

The SMBus slave interface complies with the *SMBus Specification Revision 1.0* [3]. See Section 2.1, *AC Specifications* on page 3 for more information.

## 5.3.6 BUS RESET SEQUENCE

The SMBus slave interface resets and returns to the idle state upon a START condition followed immediately by a STOP condition.

## 5.3.7 SMBUS ALERT RESPONSE ADDRESS

The SMBALERT# signal is not supported by the hub.

## 5.4 Default Configuration

To put the hub in the default configuration, strap CFG\_SEL[1:0] to 00b. This procedure configures the hub to the internal defaults and enables the strapping options. To place the hub in default configuration with overrides, see [Table 5-1 on page 19](#) for the list of the options.

The internal default values are used for the registers that are not controlled by strapping option pins. Refer to [Section 5.1 on page 19](#) for the internal default values that are loaded when this option is selected. For a list of strapping option pins, see [Section 5.0, "Initial Interface/Configuration Options"](#), and to configure the strapping pins, see [Section 3.3.1 on page 14](#).

## 5.5 Reset

The hub experiences the following two resets:

- Hardware reset via the RESET\_N pin
- USB bus reset

### 5.5.1 EXTERNAL HARDWARE RESET\_N

A valid hardware reset is defined as assertion of RESET\_N for a minimum of 1  $\mu$ s after all power supplies are within operating range. While reset is asserted, the hub (and its associated external circuitry) consumes less than 500  $\mu$ A of current from the upstream USB power source.

Assertion of RESET\_N causes the following:

1. All downstream ports are disabled, and PRTPWR[x:1] to downstream devices is removed (unless BC\_EN[x:1] is enabled).
2. The PHYs are disabled, and the differential pairs will be in a high-impedance state.
3. All transactions immediately terminate; no states are saved.
4. All internal registers return to the default state (in most cases, 00h).
5. The external crystal oscillator is halted.
6. The PLL is halted.

The hub is operational 500  $\mu$ s after RESET\_N is negated. Once operational, the hub will do one of the following, depending on configuration:

- Read the strapping pins (default configuration with strapping options enabled)
- Read configuration information from the external I<sup>2</sup>C EEPROM
- Wait for configuration over SMBus.

# USB251xB/xBi

## 5.5.1.1 RESET\_N for Strapping Option Configuration

**FIGURE 5-1: RESET\_N TIMING FOR DEFAULT CONFIGURATION**

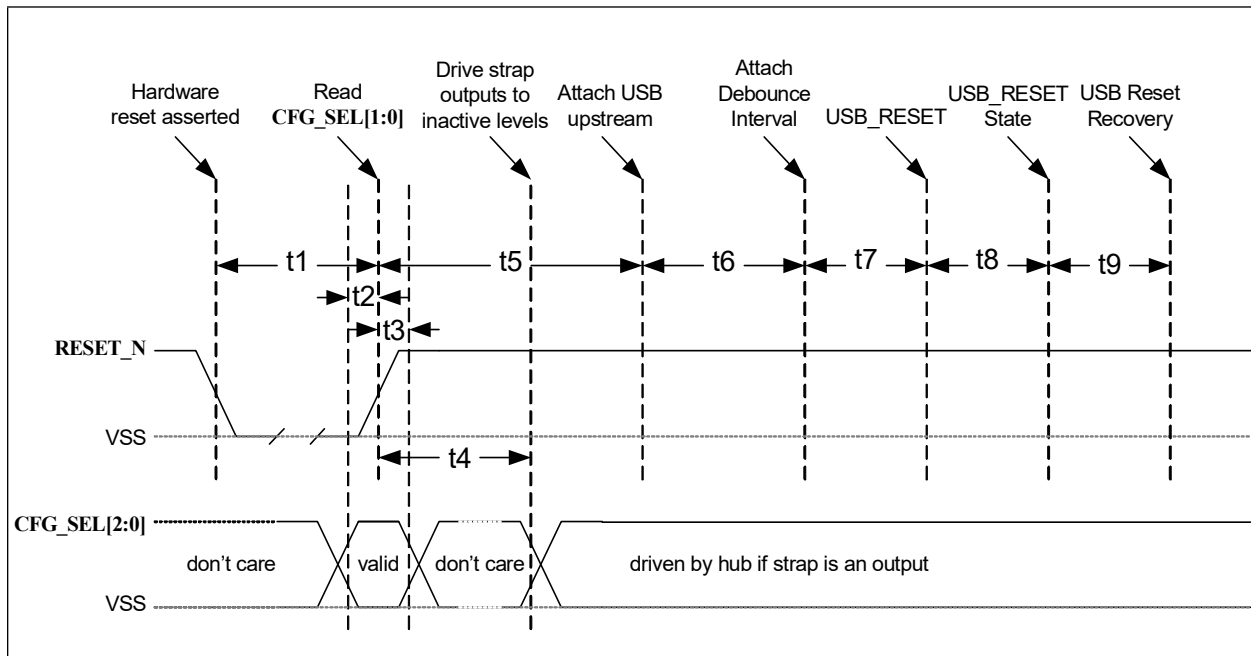

Name	Description	MIN	TYP	MAX	Units
t1	RESET_N asserted	1			μs
t2	CFG_SEL[1:0] setup time	16.7			ns
t3	CFG_SEL[1:0] hold time	16.7		1400	ns
t4	Hub outputs driven to inactive logic states		1.5	2	μs
t5	USB attach (see notes)		3		μs
t6	Host acknowledges attach and signals USB reset	100			ms
t7	USB_RESET		Host Defined		ms
t8	USB_RESET State	Note 5-1			ms
t9	USB Reset Recovery	10			ms

**Note:**

- When in bus-powered mode, the hub and its associated circuitry must not consume more than 100 mA from the upstream USB power source during t1+t5.
- All power supplies must have reached the operating levels mandated in [Section 6.0, "DC Parameters"](#), prior to (or coincident with) the assertion of RESET\_N.

**Note 5-1** 10 ms for hubs, 50 ms for root ports.

## 5.5.1.2 RESET\_N for EEPROM Configuration

**FIGURE 5-2: RESET\_N TIMING FOR EEPROM MODE**

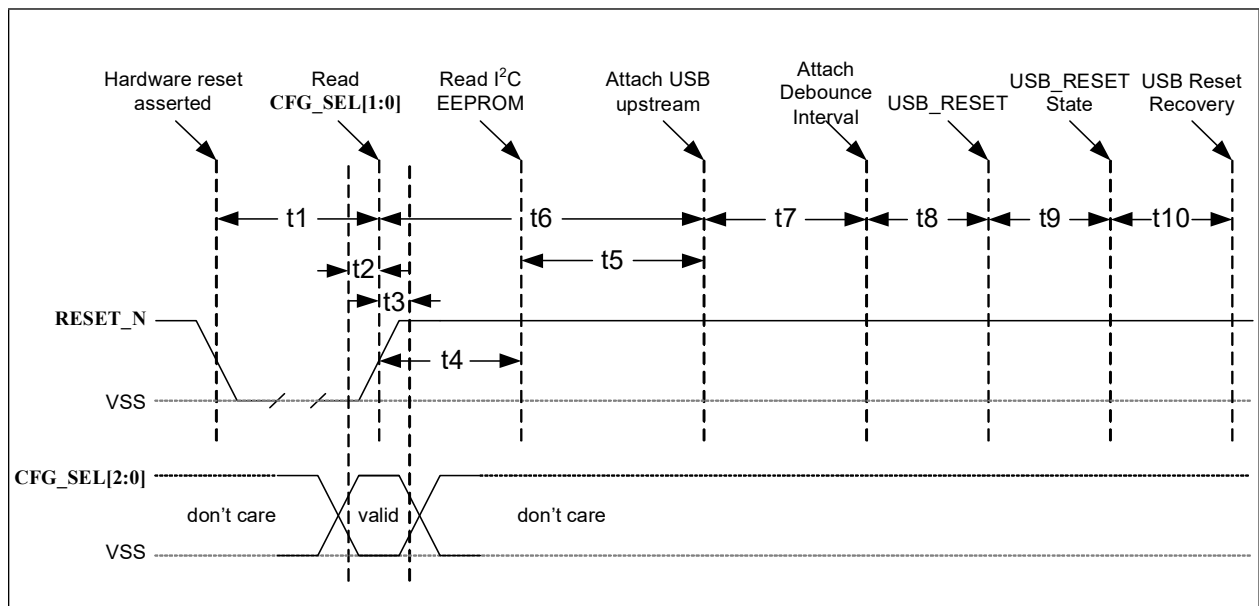

Name	Description	MIN	TYP	MAX	Units
t1	RESET_N asserted	1			μs
t2	CFG_SEL[1:0] setup time	16.7			ns
t3	CFG_SEL[1:0] hold time	16.7		1400	ns
t4	Hub recovery/stabilization			500	μs
t5	EEPROM read (hub configuration)		40		ms
t6	USB attach (see notes)		40		ms
t7	Host acknowledges attach and signals USB reset	100			ms
t8	USB_RESET		host-defined		ms
t9	USB_RESET state	Note 5-2			ms
t10	USB Reset Recovery	10			ms

**Note:**

- When in bus-powered mode, the hub and its associated circuitry must not consume more than 100 mA from the upstream USB power source during t6+t7+t8+t9.
- All power supplies must have reached the operating levels mandated in [Section 6.0, "DC Parameters"](#), prior to (or coincident with) the assertion of RESET\_N.

**Note 5-2** 10 ms for hubs, 50 ms for root ports.

# USB251xB/xBi

## 5.5.1.3 RESET\_N for SMBus Slave Configuration

**FIGURE 5-3: RESET\_N TIMING FOR SMBUS MODE**

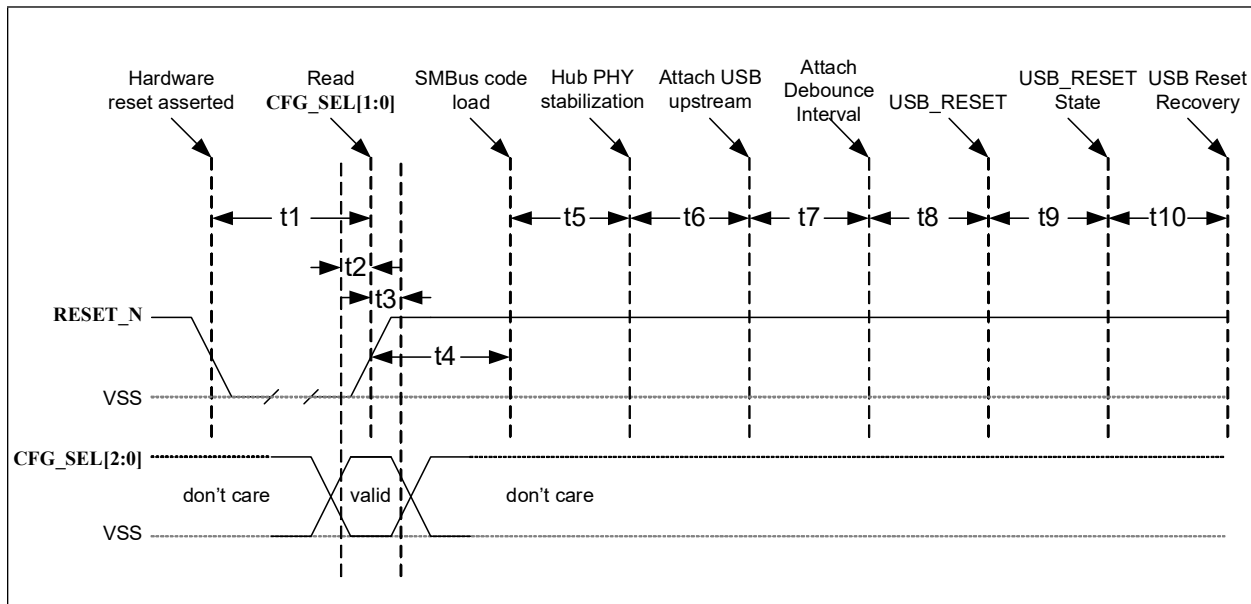

Name	Description	MIN	TYP	MAX	Units
t1	RESET_N Asserted	1			μs
t2	CFG_SEL[1:0] setup time	16.7			ns
t3	CFG_SEL[1:0] hold time	16.7		1400	ns
t4	Hub recovery/stabilization			500	μs
t5	SMBus Code Load	2		1000	ms
t6	Hub configuration and USB attach		0		ms
t7	Host acknowledges attach and signals USB reset	100			ms
t8	USB_RESET		host-defined		ms
t9	USB_RESET State	Note 5-4			ms
t10	USB Reset Recovery	10			ms

**Note 5-3** All power supplies must have reached the operating levels mandated in [Section 6.0, "DC Parameters"](#), prior to (or coincident with) the assertion of RESET\_N.

**Note 5-4** 10 ms for hubs, 50 ms for root ports.

## 5.5.2 USB BUS RESET

In response to the upstream port signaling a reset to the hub, the hub does the following:

1. Sets default internal USB address to 0
2. Sets configuration to: unconfigured
3. Negates PRTPWR[x:1] to all downstream ports unless battery charging (BC\_EN[x:1]) is enabled
4. Clears all TT buffers
5. Moves device from suspended to active (if suspended)
6. Complies with Section 11.10 of the *USB 2.0 Specification [1]* for behavior after completion of the reset sequence. The host then configures the hub and the hub's downstream port devices in accordance with the *USB Specification*.

**Note:** The hub does not propagate the upstream USB reset to downstream devices.

## 6.0 DC PARAMETERS

### 6.1 Maximum Ratings

Parameter	Symbol	MIN	MAX	Units	Comments
Storage Temperature	T <sub>STOR</sub>	-55	150	°C	
Lead Temperature					Refer to <i>JEDEC Specification J-STD-020D</i> [5]
3.3 V supply voltage	VDD33 VDDA33		4.6	V	Applies to all packages
Voltage on any I/O pin		-0.5	5.5	V	
Voltage on XTALIN		-0.5	4.0	V	
Voltage on XTALOUT		-0.5	2.5	V	

#### Note 6-1

- Stresses above the specified parameters could cause permanent damage to the device. This is a stress rating only. Therefore, functional operation of the device at any condition above those indicated in the operation sections of this specification are not implied.
- When powering this device from laboratory or system power supplies, it is important that the absolute maximum ratings not be exceeded or device failure can result. Some power supplies exhibit voltage spikes on their outputs when the AC power is switched on or off. In addition, voltage transients on the AC power line may appear on the DC output. When this possibility exists, it is suggested that a clamp circuit be used.

### 6.2 Operating Conditions

Parameter	Symbol	MIN	MAX	Units	Comments
Extended Commercial Operating Temperature	T <sub>AE</sub>	0	85	°C	Ambient temperature in still air
Industrial Operating Temperature	T <sub>AI</sub>	-40	85	°C	Ambient temperature in still air Only applies to USB251xBi products
3.3 V supply voltage	VDD33 VDDA33	3.0	3.6	V	Applies to all parts
3.3 V supply rise time	t <sub>RT33</sub>	0	400	µs	See <a href="#">Figure 6-1</a> and <a href="#">Note 6-2</a>
Voltage on any I/O pin		-0.3	5.5	V	If any 3.3 V supply voltage drops below 3.0 V, then the MAX becomes: (3.3 V supply voltage) + 0.5
Voltage on XTALIN		-0.3	VDD33	V	

# USB251xB/xBi

**FIGURE 6-1: SUPPLY RISE TIME MODEL**

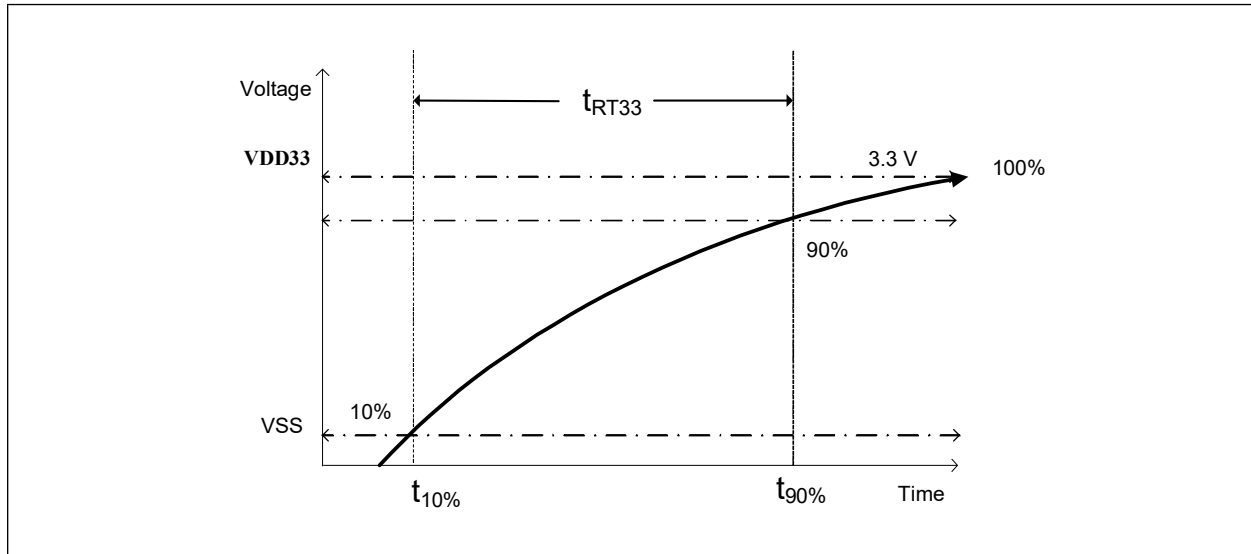

**Note 6-2** The rise time for the 3.3 V supply can be extended to 100 ms max if RESET\_N is actively driven low, typically by another IC, until 1  $\mu$ s after all supplies are within operating range.

**TABLE 6-1: DC ELECTRICAL CHARACTERISTICS**

Parameter	Symbol	MIN	TYP	MAX	Units	Comments
<b>I, IS Type Input Buffer</b>						
Low Input Level	$V_{ILI}$			0.8	V	TTL Levels
High Input Level	$V_{IHI}$	2.0			V	
Input Leakage	$I_{IL}$	-10		+10	$\mu$ A	$V_{IN} = 0$ to <b>VDD33</b>
Hysteresis (IS only)	$V_{HYSI}$	250		350	mV	
<b>Input Buffer with Pull-Up (IPU)</b>						
Low Input Level	$V_{ILI}$			0.8	V	TTL Levels
High Input Level	$V_{IHI}$	2.0			V	
Low Input Leakage	$I_{ILL}$	+35		+90	$\mu$ A	$V_{IN} = 0$
High Input Leakage	$I_{IHL}$	-10		+10	$\mu$ A	$V_{IN} = \mathbf{VDD33}$
<b>Input Buffer with Pull-Down (IPD)</b>						
Low Input Level	$V_{ILI}$			0.8	V	TTL Levels
High Input Level	$V_{IHI}$	2.0			V	
Low Input Leakage	$I_{ILL}$	+10		-10	$\mu$ A	$V_{IN} = 0$
High Input Leakage	$I_{IHL}$	-35		-90	$\mu$ A	$V_{IN} = \mathbf{VDD33}$
<b>USB251xB/xBi ICLK Input Buffer</b>						
Low Input Level	$V_{ILCK}$			0.3	V	
High Input Level	$V_{IHCK}$	0.9			V	
Input Leakage	$I_{IL}$	-10		+10	$\mu$ A	$V_{IN} = 0$ to <b>VDD33</b>

**TABLE 6-1: DC ELECTRICAL CHARACTERISTICS (CONTINUED)**

Parameter	Symbol	MIN	TYP	MAX	Units	Comments
<b>O12, I/O12 &amp; I/OSD12 Type Buffer</b>						
Low Output Level	$V_{OL}$			0.4	V	$I_{OL} = 12 \text{ mA @ } V_{DD33} = 3.3 \text{ V}$
High Output Level	$V_{OH}$	2.4			V	$I_{OH} = -12 \text{ mA @ } V_{DD33} = 3.3 \text{ V}$
Output Leakage	$I_{OL}$	-10		+10	$\mu\text{A}$	
Hysteresis (SD pad only)	$I_{HYSC}$	250		350	mV	$V_{IN} = V_{DD33}$ (Note 6-1)

**Note 6-3** Output leakage is measured with the current pins in high impedance.

**Note 6-4** See *USB 2.0 Specification [1]* for USB DC electrical characteristics.

**TABLE 6-2: SUPPLY CURRENT UNCONFIGURED: HI-SPEED HOST ( $I_{CCINTHS}$ )**

Part	MIN	TYP	MAX	Units	Comments
USB2512B/12Bi		40	45	mA	
USB2513B/13Bi		40	45	mA	
USB2514B/14Bi		45	50	mA	

**TABLE 6-3: SUPPLY CURRENT UNCONFIGURED: FULL-SPEED HOST ( $I_{CCINTFS}$ )**

Part	MIN	TYP	MAX	Units	Comments
USB2512B/12Bi		35	40	mA	
USB2513B/13Bi		35	40	mA	
USB2514B/14Bi		35	40	mA	

**TABLE 6-4: SUPPLY CURRENT CONFIGURED: HI-SPEED HOST ( $I_{HCH1}$ )**

Part	MIN	TYP	MAX	Units	Comments
USB2512B		60	65	mA	This is the base current of one downstream port.
USB2512Bi		60	70	mA	
USB2513B		65	70	mA	
USB2513Bi		65	75	mA	
USB2514B		70	80	mA	
USB2514Bi		70	85	mA	
<b>USB251xB/xBi Supply Current Configured Hi-Speed Host, each additional downstream port</b>		<b>1 port base + 25 mA</b>	<b>1 port base + 25 mA</b>	mA	

# USB251xB/xBi

**TABLE 6-5: SUPPLY CURRENT CONFIGURED: FULL-SPEED HOST ( $I_{FCC1}$ )**

Part	MIN	TYP	MAX	Units	Comments
USB2512B		45	50	mA	Base current of one downstream port
USB2512Bi		45	55	mA	
USB2513B		50	55	mA	
USB2513Bi		50	60	mA	
USB2514B		50	60	mA	
USB2514Bi		50	65	mA	
<b>USB251xB/xBi Supply Current Configured Full-Speed Host, each additional downstream port</b>		<b>1 port base + 8 mA</b>	<b>1 port base + 8 mA</b>	mA	

**TABLE 6-6: SUPPLY CURRENT SUSPEND ( $I_{CSBY}$ )**

Part	MIN	TYP	MAX	Units	Comments
USB2512B		475	1000	$\mu$ A	All supplies combined
USB2512Bi		475	1200	$\mu$ A	
USB2513B		500	1100	$\mu$ A	
USB2513Bi		500	1300	$\mu$ A	
USB2514B		550	1200	$\mu$ A	
USB2514Bi		550	1500	$\mu$ A	

**TABLE 6-7: SUPPLY CURRENT RESET ( $I_{CRST}$ )**

Part	MIN	TYP	MAX	Units	Comments
USB2512B		550	1100	$\mu$ A	All supplies combined
USB2512Bi		550	1250	$\mu$ A	
USB2513B		650	1200	$\mu$ A	
USB2513Bi		650	1400	$\mu$ A	
USB2514B		750	1400	$\mu$ A	
USB2514Bi		750	1600	$\mu$ A	

**TABLE 6-8: PIN CAPACITANCE**

Parameter	Symbol	Limits			Unit	Test Condition
		MIN	TYP	MAX		
Clock Input Capacitance	$C_{XTAL}$			6	pF	All pins except USB pins and the pins under the test tied to AC ground
Input Capacitance	$C_{IN}$			6	pF	(Note 6-5)
Output Capacitance	$C_{OUT}$			6	pF	

**Note 6-5** Capacitance  $T_A = 25^\circ\text{C}$ ;  $f_c = 1\text{ MHz}$ ;  $V_{DD33} = 3.3\text{ V}$

## 6.2.1 PACKAGE THERMAL SPECIFICATIONS

Thermal parameters are measured or estimated for devices with the exposed pad soldered to thermal vias in a multi-layer 2S2P PCB per JESD51. Thermal resistance is measured from the die to the ambient air. The values provided are based on the package body, die size, maximum power consumption, 85°C ambient temperature, and 125°C junction temperature of the die.

Symbol	USB2512B/12Bi USB2513B/13Bi USB2514B/14Bi (°C/W)	Velocity (meters/s)
	$\Theta_{JA}$	
$\Psi_{JT}$	0.5 0.7	0 1
	$\Theta_{JC}$	6.3 6.3

Use the following formulas to calculate the junction temperature:

$$T_J = P \times \Theta_{JA} + T_A$$

$$T_J = P \times \Psi_{JT} + T_T$$

$$T_J = P \times \Theta_{JC} + T_C$$

$$\text{Max Power Supported} = (T_{J \text{ Max. Spec.}} - T_{\text{Amb.}}) / \Theta_{JA}$$

**TABLE 6-9: LEGEND**

Symbol	Description
$T_J$	Junction temperature
$P$	Power dissipated
$\Theta_{JA}$	Junction-to-ambient-temperature
$\Theta_{JC}$	Junction-to-top-of-package
$\Psi_{JT}$	Junction-to-bottom-of-case
$T_A$	Ambient temperature
$T_C$	Temperature of the bottom of the case
$T_T$	Temperature of the top of the case

# USB251xB/xBi

## 7.0 AC SPECIFICATIONS

### 7.1 Oscillator/Crystal

Crystal: Parallel resonant, fundamental mode, 24 MHz  $\pm$ 350 ppm.

**Note:** The USB251xB/xBi contains an internal 1 M $\Omega$  resistor between the XTALIN and XTALOUT pins.

**FIGURE 7-1: TYPICAL CRYSTAL CIRCUIT**

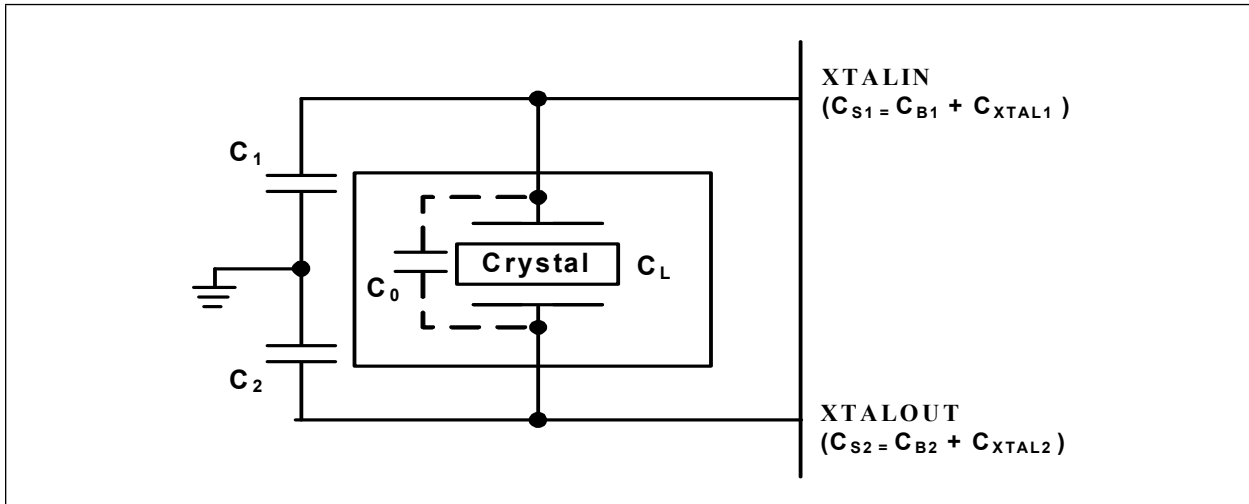

**TABLE 7-1: CRYSTAL CIRCUIT LEGEND**

Symbol	Description	In Accordance with
$C_0$	Crystal shunt capacitance	Crystal manufacturer's specification ( <a href="#">Note 7-1</a> )
$C_L$	Crystal load capacitance	
$C_B$	Total board or trace capacitance	OEM board design
$C_S$	Stray capacitance	Microchip IC and OEM board design
$C_{XTAL}$	XTAL pin input capacitance	Microchip IC
$C_1$ $C_2$	Load capacitors installed on OEM board	Calculated values based on <a href="#">Figure 7-2</a> ( <a href="#">Note 7-2</a> )

**FIGURE 7-2: FORMULA TO FIND THE VALUE OF  $C_1$  AND  $C_2$**

$$C_1 = 2 \times (C_L - C_0) - C_{S1}$$

$$C_2 = 2 \times (C_L - C_0) - C_{S2}$$

**Note 7-1**  $C_0$  is usually included (subtracted by the crystal manufacturer) in the specification for  $C_L$  and should be set to 0 for use in the calculation of the capacitance formulas in [Figure 7-2](#). However, the PCB itself may present a parasitic capacitance between XTALIN and XTALOUT. For an accurate calculation of  $C_1$  and  $C_2$ , take the parasitic capacitance between traces XTALIN and XTALOUT into account.

**Note 7-2** Each of these capacitance values is typically around 18 pF.

## 7.2 External Clock

50% duty cycle  $\pm$  10%, 24 MHz  $\pm$  350 ppm, jitter < 100 ps rms.

The external clock is recommended to conform to the signaling level designated in the *JESD76-2 Specification* [5] on 1.2 V CMOS Logic. XTALOUT should be treated as a weak (<1mA) buffer output.

### 7.2.1 SMBUS INTERFACE

The hub conforms to all voltage, power, and timing characteristics and specifications as set forth in the *SMBus 1.0 Specification* [3] for slave-only devices (except as noted in [Section 5.3, "SMBus," on page 33](#)).

### 7.2.2 I<sup>2</sup>C EEPROM

Clock frequency is fixed at 60 kHz  $\pm$  20%.

### 7.2.3 USB 2.0

The Microchip hub conforms to all voltage, power, and timing characteristics and specifications as set forth in the *USB 2.0 Specification* [1].

# USB251xB/xBi

## 8.0 PACKAGE MARKING INFORMATION

The following sub-sections detail the package marking information for the 36-pin SQFN and 36-pin QFN packages. To order or obtain information, e.g., on pricing or delivery, refer to the factory or the listed sales office.

**Note:** The diagrams shown in this section are examples only. Actual markings may be justified center or left.

### 8.1 36-Pin SQFN (Preferred)

36-Lead SQFN (6x6x0.9 mm)

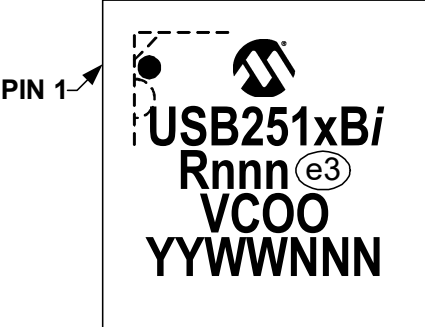

Example

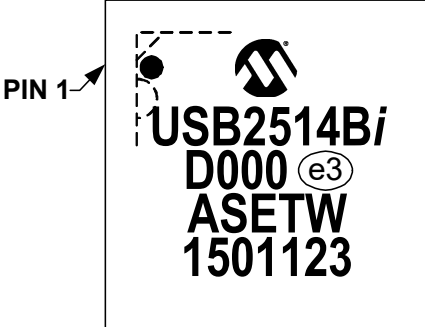

**Legend:**

x	USB251xB version (2 = 2-port, 3 = 3-port, 4 = 4-port)
i	Temperature range designator (Blank = commercial, i = industrial)
R	Product revision
nnn	Internal code
e3	Pb-free JEDEC® designator for Matte Tin (Sn)
V	Plant of assembly
COO	Country of origin
YY	Year code (last two digits of calendar year)
WW	Week code (week of January 1 is week '01')
NNN	Alphanumeric traceability code

**Note:** In the event the full Microchip part number cannot be marked on one line, it will be carried over to the next line, thus limiting the number of available characters for customer-specific information.

\* Standard device marking consists of Microchip part number, year code, week code and traceability code. For device marking beyond this, certain price adders apply. Please check with your Microchip Sales Office. For QTP devices, any special marking adders are included in QTP price.

## 8.2 36-Pin QFN (Legacy)

36-Lead QFN (6x6x0.9 mm)

Example

**Legend:**

<i>x</i>	USB251xB version (2 = 2-port, 3 = 3-port, 4 = 4-port)
<i>i</i>	Temperature range designator: (Blank = commercial, <i>i</i> = industrial)
R	Product revision
YY	Year code (last two digits of calendar year)
WW	Week code (week of January 1 is week '01')
A2P10	Internal code
NNN	Alphanumeric traceability code
A	Fixed character
V	Plant of assembly
COO	Country of origin
e3	Pb-free JEDEC® designator for Matte Tin (Sn)

**Note:** In the event the full Microchip part number cannot be marked on one line, it will be carried over to the next line, thus limiting the number of available characters for customer-specific information.

\* Standard device marking consists of Microchip part number, year code, week code and traceability code. For device marking beyond this, certain price adders apply. Please check with your Microchip Sales Office. For QTP devices, any special marking adders are included in QTP price.

## 9.0 PACKAGE INFORMATION

**Note:** For the most current package drawings, see the Microchip Packaging Specification at <http://www.microchip.com/packaging>.

### 9.1 36-Pin SQFN (Preferred)

**FIGURE 9-1: 36-PIN SQFN PACKAGE DRAWING**

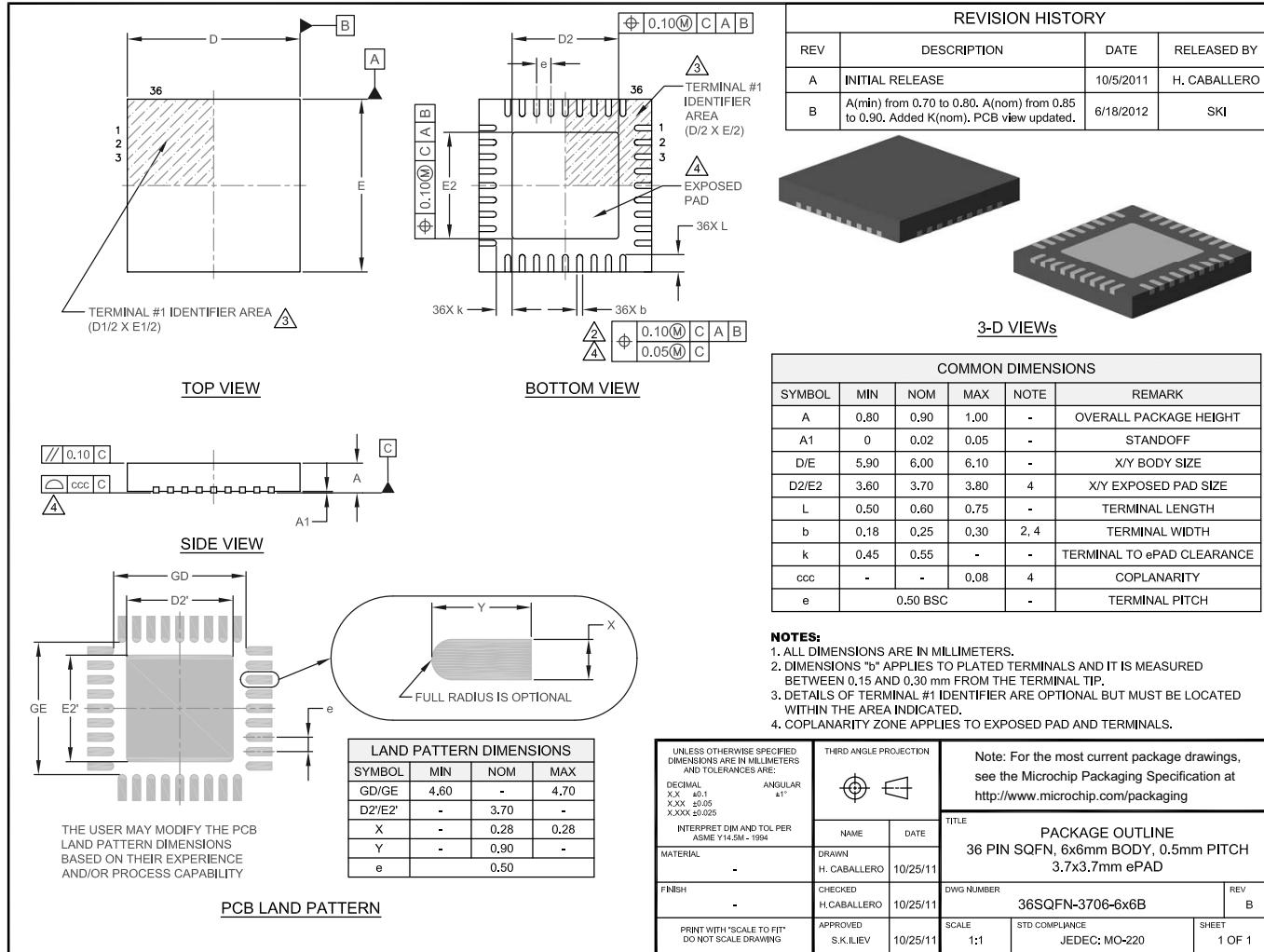

## 9.2 36-Pin QFN (Legacy)

FIGURE 9-2: 36-PIN QFN PACKAGE DRAWING

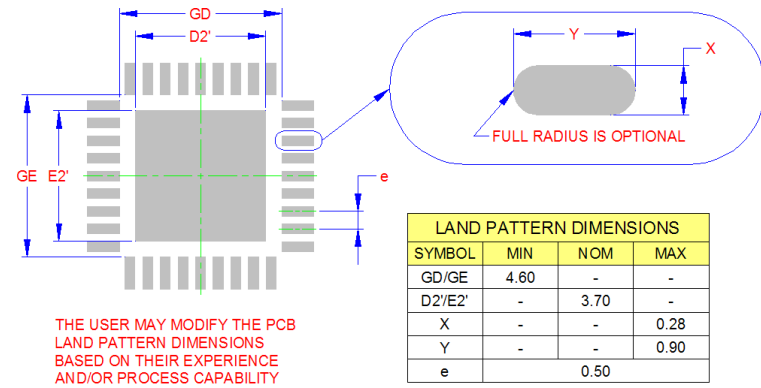
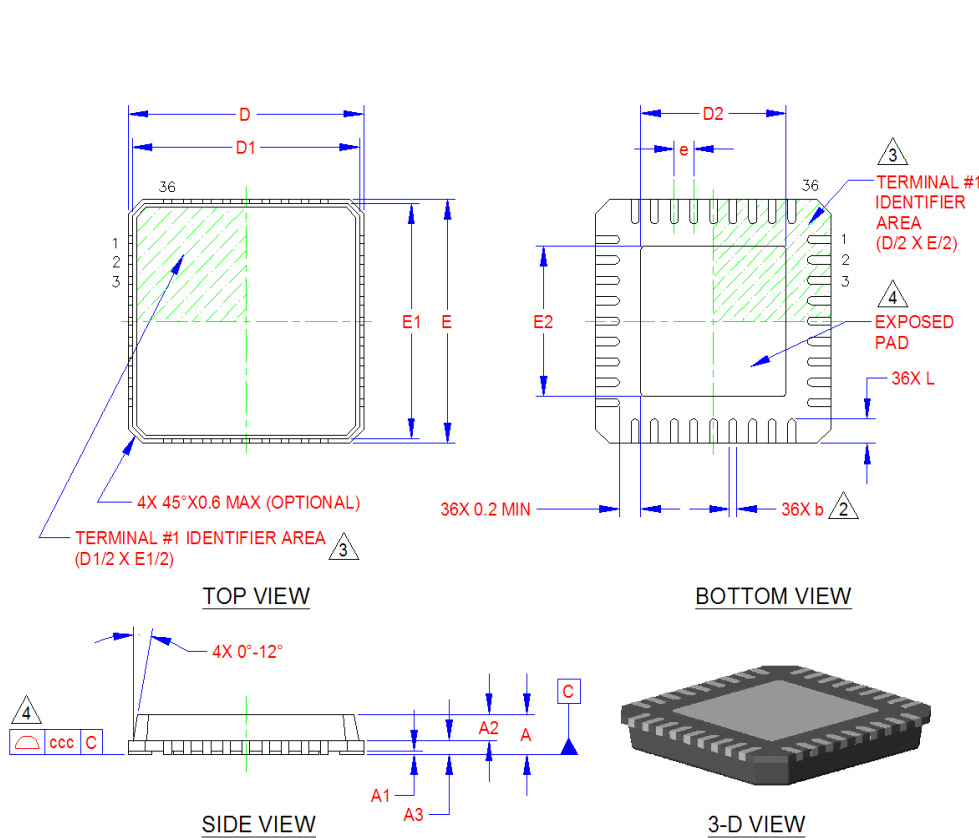

### RECOMMENDED PCB LAND PATTERN

COMMON DIMENSIONS						
SYMBOL	MIN	NOM	MAX	NOTE	REMARK	
A	0.80	-	1.00	-	OVERALL PACKAGE HEIGHT	
A1	0	0.02	0.05	-	STANDOFF	
A2	0.60	-	0.80	-	MOLD CAP THICKNESS	
A3	0.20 REF			-	LEADFRAME THICKNESS	
D/E	5.85	6.00	6.15	-	X/Y BODY SIZE	
D1/E1	5.55	-	5.95	-	X/Y MOLD CAP SIZE	
D2/E2	3.55	3.70	3.85	2	X/Y EXPOSED PAD SIZE	
L	0.50	0.60	0.75	-	TERMINAL LENGTH	
b	0.18	0.25	0.30	2	TERMINAL WIDTH	
e	0.50 BSC			-	TERMINAL PITCH	

### NOTES:

- ALL DIMENSIONS ARE IN MILLIMETERS.
- POSITION TOLERANCE OF EACH TERMINAL AND EXPOSED PAD IS  $\pm 0.05$ mm AT MAXIMUM MATERIAL CONDITION. DIMENSIONS "b" APPLIES TO PLATED TERMINALS AND IT IS MEASURED BETWEEN 0.15 AND 0.30 mm FROM THE TERMINAL TIP.
- DETAILS OF TERMINAL #1 IDENTIFIER ARE OPTIONAL BUT MUST BE LOCATED WITHIN THE AREA INDICATED.
- COPLANARITY ZONE APPLIES TO EXPOSED PAD AND TERMINALS.

# USB251xB/xBi

---

---

## APPENDIX A: ACRONYMS

<b>I<sup>2</sup>C:</b>	Inter-Integrated Circuit
<b>OCS:</b>	Over-Current Sense
<b>PCB:</b>	Printed Circuit Board
<b>PHY:</b>	Physical Layer
<b>PLL:</b>	Phase-Locked Loop
<b>QFN:</b>	Quad Flat No Leads
<b>RoHS:</b>	Restriction of Hazardous Substances Directive
<b>SCL:</b>	Serial Clock
<b>SIE:</b>	Serial Interface Engine
<b>SMBus:</b>	System Management Bus
<b>TT:</b>	Transaction Translator

## APPENDIX B: REFERENCES

1. Universal Serial Bus Specification, Version 2.0, April 27, 2000 (12/7/2000 and 5/28/2002 Errata)  
USB Implementers Forum, Inc. <http://www.usb.org>
2. I<sup>2</sup>C-Bus Specification Version 1.1  
NXP (formerly a division of Philips). <http://www.nxp.com>
3. System Management Bus Specification, version 1.0  
SMBus. <http://smbus.org/specs/>
4. MicroChip 24AA02/24LC02B (Revision C)  
Microchip Technology Inc. <http://www.microchip.com/>
5. JEDEC Specifications: JESD76-2 (June 2001) and J-STD-020D.1 (March 2008)  
JEDEC Global Standards for the Microelectronics Industry. <http://www.jedec.org/standards-documents>

# USB251xB/xBi

## APPENDIX C: DATA SHEET REVISION HISTORY

TABLE C-1: REVISION HISTORY

Revision Level & Date	Section/Figure/Entry	Correction
DS00001692E (07-11-23)	<a href="#">Section 8.0, "Package Marking Information"</a>	The following note has been added: "The diagrams shown in this section are examples only. Actual markings may be justified center or left."
DS00001692D (04-25-22)	<a href="#">Section 6.2.1, "Package Thermal Specifications"</a>	Formula for max power dissipation updated.
DS00001692C (10-20-15)	<a href="#">Product Identification System</a>	PIS ordering code information for preferred package corrected to align with current Microchip standard practices.
	<a href="#">Section 8.0, "Package Marking Information"</a>	Top marking diagrams corrected to be consistent with internal specifications and current physical part markings.
DS00001692B (08-12-15)	All	Added new 36-SQFN package option information (drawings, ordering codes, top markings, etc.)
	Cover, <a href="#">Product Identification System</a>	Updated document with new ordering section. Removed previous ordering section from cover.
	<a href="#">Section 8.0, "Package Marking Information"</a>	Added new package marking chapter.
REV A	REV A replaces previous SMSC version Rev. 2.4 (11-08-13).  Document is Microchip branded, mention of SMSC is removed.  Order numbers modified adding "G" or "C" as last character to suffix.  The following note added to Package Outline chapter: "For the most current package drawings, see the Microchip Packaging Specification at <a href="http://www.microchip.com/packaging">http://www.microchip.com/packaging</a> ."	
Rev. 2.4 (11-08-13)	<a href="#">Section 5.2.1, "I2C Slave Address"</a>	Corrected slave address to "1010000b".
	<a href="#">Figure 3-1, Figure 3-2, Figure 3-3, Table 3-1</a>	Corrected pin 36 name (VDDA33).
	<a href="#">Section 5.5.1.1, "RESET_N for Strapping Option Configuration"</a>	Updated timing diagram and values. Changed t6, t7, t8 name and added new t9. Updated t5 and t8 values.
	<a href="#">Section 5.5.1.2, "RESET_N for EEPROM Configuration"</a>	Updated timing diagram and values. Changed t7, t8, and t9 name and added new t10. Updated t5, t6, and t9 values.
	<a href="#">Section 5.5.1.3, "RESET_N for SMBus Slave Configuration"</a>	Updated timing diagram and values. Changed t7, t8, and t9 name and added new t10. Updated t5, t6, and t9 values. Removed t5 "bus" and "self" distinction.
	<a href="#">Note 6-2</a>	Added note regarding 3.3 V supply rise time.
Rev. 2.3 (06-11-13)	<a href="#">Table 3-1, "USB251xB/xBi Pin List (Alphabetical)," on page 10</a>	Corrected errant description "Server Message Block" to "System Management Bus".
	<a href="#">Section 7.1, "Oscillator/Crystal," on page 44 and FIGURE 7-1: Typical Crystal Circuit on page 44</a>	Updated figure to remove external 1 MΩ requirement. Added note indicating the device includes and internal 1 MΩ resistor between the XTALIN and XTALOUT pins.
	<a href="#">FIGURE 3-3: USB2514B Pin Diagram on page 9</a>	Corrected typo on pin 6.
	<a href="#">FIGURE 3-1: USB2512B Pin Diagram on page 7 &amp; Table 3-1, "USB251xB/xBi Pin List (Alphabetical)," on page 10</a>	Added alternate port disable functions to pins 1-4 of the USB2512B.

**TABLE C-1: REVISION HISTORY (CONTINUED)**

Revision Level & Date	Section/Figure/Entry	Correction
Rev. 2.2 (02-17-12)	Cover	Updated clock bullet to remove reference to 48MHz clock support.
	<a href="#">Section 1.1, "Configurable Features," on page 4</a>	Updated bulleted lists. USB signal drive strength, USB differential pair pin location and downstream port power control / over-current detection items moved from first (strap-configurable) bulleted list to the second (EEPROM-configurable) bulleted list. Added enabling of battery charging to the first bulleted list.
	<a href="#">Section 3.1, "Pin Configurations," on page 7</a>	Clarified introductory sentence.
	<a href="#">Table 3-2, "USB251xB/xBi Pin Descriptions," on page 12</a>	Updated VBUS_DET buffer type to "I" and changed description to: "For self-powered applications with a permanently attached host, this pin must be connected to a dedicated host control output, or connected to the 3.3 V domain that powers the host (typically VDD33)."
	<a href="#">Table 3-2, "USB251xB/xBi Pin Descriptions," on page 12</a>	Updated CRFILT and PLLFILT pin descriptions.
	<a href="#">Section 7.1, "Oscillator/Crystal," on page 44</a>	Removed redundant sentence: "External Clock: 50% duty cycle $\pm$ 10%, 24/48 MHz $\pm$ 350 ppm, jitter < 100 ps rms". This information is provided in <a href="#">Section 7.2, "External Clock," on page 45</a> .
	<a href="#">Section 7.0, "AC Specifications"</a>	Removed ceramic resonator information.
	<a href="#">Section 7.2, "External Clock"</a>	Replaced "1.8 V CMOS Logic" with "1.2 V CMOS Logic". Updated XTALOUT description.
	<a href="#">Section 3.3, "Pin Descriptions (Grouped by Function)"</a>	Updated CRFILT and PLLFILT pin descriptions.
	Cover, Package, All	Removed the 49-BGA option.
	Order Code Page	Changed ordering codes for non-industrial USB2513B and USB2514B. Last character was changed from "G" to "C".
	Front page	Removed support for ceramic resonator.
Rev. 2.1 (02-22-11)	<a href="#">Section 6.2.1, Package Thermal Specifications</a>	Added Max Power Supported = $(T_J, \text{max.spec.} - T_{\text{amb}}) / \Theta_{JA}$
Rev. 2.0 (10-01-10)	All	General refresh, corrected grammatical errors and unified tone.

# USB251xB/xBi

---

---

## THE MICROCHIP WEB SITE

Microchip provides online support via our WWW site at [www.microchip.com](http://www.microchip.com). This web site is used as a means to make files and information easily available to customers. Accessible by using your favorite Internet browser, the web site contains the following information:

- **Product Support** – Data sheets and errata, application notes and sample programs, design resources, user's guides and hardware support documents, latest software releases and archived software
- **General Technical Support** – Frequently Asked Questions (FAQ), technical support requests, online discussion groups, Microchip consultant program member listing
- **Business of Microchip** – Product selector and ordering guides, latest Microchip press releases, listing of seminars and events, listings of Microchip sales offices, distributors and factory representatives

## CUSTOMER CHANGE NOTIFICATION SERVICE

Microchip's customer notification service helps keep customers current on Microchip products. Subscribers will receive e-mail notification whenever there are changes, updates, revisions or errata related to a specified product family or development tool of interest.

To register, access the Microchip web site at [www.microchip.com](http://www.microchip.com). Under "Support", click on "Customer Change Notification" and follow the registration instructions.

## CUSTOMER SUPPORT

Users of Microchip products can receive assistance through several channels:

- Distributor or Representative
- Local Sales Office
- Field Application Engineer (FAE)
- Technical Support

Customers should contact their distributor, representative or field application engineer (FAE) for support. Local sales offices are also available to help customers. A listing of sales offices and locations is included in the back of this document.

Technical support is available through the web site at: <http://www.microchip.com/support>

## PRODUCT IDENTIFICATION SYSTEM

The USB251xB/xBi is available in a 36-pin SQFN (preferred) and 36-pin QFN (legacy) package. For new designs, the 36-pin SQFN is recommended. The ordering code information varies dependent on the package selected. The following sub-sections detail the product identification system for the 36-pin SQFN (preferred) and 32-pin QFN (legacy). To order or obtain information, e.g., on pricing or delivery, refer to the factory or the listed sales office.

### 36-Pin SQFN (Preferred)

PART NO.	[X] <sup>(1)</sup>	[-X]	/	XX	<b>Examples:</b>
Device	Tape and Reel Option	Temperature Range		Package	
<b>Device:</b> USB2512B = 2-Port USB 2.0 Hub USB2513B = 3-Port USB 2.0 Hub USB2514B = 4-Port USB 2.0 Hub					a) USB2512B/M2 2-Port USB hub, Tray, Extended commercial temp, 36-pin SQFN  b) USB2514BT-I/M2 4-Port USB hub, Tape & reel, Industrial temp., 36-pin SQFN
<b>Tape and Reel Option:</b>	Blank = Standard packaging (tray) T = Tape and Reel ( <a href="#">Note 1</a> )				
<b>Temperature Range:</b>	Blank = 0°C to +85°C (Extended Commercial) I = -40°C to +85°C (Industrial)				
<b>Package:</b>	M2 = 36-pin SQFN				
					<b>Note 1:</b> Reel size is 3,000 pieces. Tape and Reel identifier only appears in the catalog part number description. This identifier is used for ordering purposes and is not printed on the device package. Check with your Microchip Sales Office for package availability with the Tape and Reel option.

### 36-Pin QFN (Legacy)

Order Numbers*	ROHS Compliant Package	Package Size (mm)	Temperature Range
USB2512B-AEZG USB2513B-AEZC USB2514B-AEZC	36-QFN	6x6	0°C to 85°C
USB2512Bi-AEZG USB2513Bi-AEZG USB2514Bi-AEZG			-40°C to 85°C

\* Add "-TR" to the end of any QFN order number to order tape and reel. Reel size is 3,000 pieces.

# USB251xB/xBi

---

---

## Note the following details of the code protection feature on Microchip products:

- Microchip products meet the specifications contained in their particular Microchip Data Sheet.
- Microchip believes that its family of products is secure when used in the intended manner, within operating specifications, and under normal conditions.
- Microchip values and aggressively protects its intellectual property rights. Attempts to breach the code protection features of Microchip product is strictly prohibited and may violate the Digital Millennium Copyright Act.
- Neither Microchip nor any other semiconductor manufacturer can guarantee the security of its code. Code protection does not mean that we are guaranteeing the product is "unbreakable". Code protection is constantly evolving. Microchip is committed to continuously improving the code protection features of our products.

---

This publication and the information herein may be used only with Microchip products, including to design, test, and integrate Microchip products with your application. Use of this information in any other manner violates these terms. Information regarding device applications is provided only for your convenience and may be superseded by updates. It is your responsibility to ensure that your application meets with your specifications. Contact your local Microchip sales office for additional support or, obtain additional support at <https://www.microchip.com/en-us/support/design-help/client-support-services>.

THIS INFORMATION IS PROVIDED BY MICROCHIP "AS IS". MICROCHIP MAKES NO REPRESENTATIONS OR WARRANTIES OF ANY KIND WHETHER EXPRESS OR IMPLIED, WRITTEN OR ORAL, STATUTORY OR OTHERWISE, RELATED TO THE INFORMATION INCLUDING BUT NOT LIMITED TO ANY IMPLIED WARRANTIES OF NON-INFRINGEMENT, MERCHANTABILITY, AND FITNESS FOR A PARTICULAR PURPOSE, OR WARRANTIES RELATED TO ITS CONDITION, QUALITY, OR PERFORMANCE.

IN NO EVENT WILL MICROCHIP BE LIABLE FOR ANY INDIRECT, SPECIAL, PUNITIVE, INCIDENTAL, OR CONSEQUENTIAL LOSS, DAMAGE, COST, OR EXPENSE OF ANY KIND WHATSOEVER RELATED TO THE INFORMATION OR ITS USE, HOWEVER CAUSED, EVEN IF MICROCHIP HAS BEEN ADVISED OF THE POSSIBILITY OR THE DAMAGES ARE FORESEEABLE. TO THE FULLEST EXTENT ALLOWED BY LAW, MICROCHIP'S TOTAL LIABILITY ON ALL CLAIMS IN ANY WAY RELATED TO THE INFORMATION OR ITS USE WILL NOT EXCEED THE AMOUNT OF FEES, IF ANY, THAT YOU HAVE PAID DIRECTLY TO MICROCHIP FOR THE INFORMATION.

Use of Microchip devices in life support and/or safety applications is entirely at the buyer's risk, and the buyer agrees to defend, indemnify and hold harmless Microchip from any and all damages, claims, suits, or expenses resulting from such use. No licenses are conveyed, implicitly or otherwise, under any Microchip intellectual property rights unless otherwise stated.

## Trademarks

The Microchip name and logo, the Microchip logo, Adaptec, AnyRate, AVR, AVR logo, AVR Freaks, BesTime, BitCloud, CryptoMemory, CryptoRF, dsPIC, flexPWR, HELDO, IGLOO, JukeBlox, KeeLoq, Klear, LANCheck, LinkMD, maXStylus, maXTouch, MediaLB, megaAVR, Microsemi, Microsemi logo, MOST, MOST logo, MPLAB, OptoLyzer, PIC, picoPower, PICSTART, PIC32 logo, PolarFire, Prochip Designer, QTouch, SAM-BA, SenGenuity, SpyNIC, SST, SST Logo, SuperFlash, Symmetricom, SyncServer, Tachyon, TimeSource, tinyAVR, UNI/O, Vectron, and XMEGA are registered trademarks of Microchip Technology Incorporated in the U.S.A. and other countries.

AgileSwitch, APT, ClockWorks, The Embedded Control Solutions Company, EtherSynch, Flashtec, Hyper Speed Control, HyperLight Load, IntelliMOS, Libero, motorBench, mTouch, Powermite 3, Precision Edge, ProASIC, ProASIC Plus, ProASIC Plus logo, Quiet-Wire, SmartFusion, SyncWorld, Temux, TimeCesium, TimeHub, TimePictra, TimeProvider, TrueTime, WinPath, and ZL are registered trademarks of Microchip Technology Incorporated in the U.S.A.

Adjacent Key Suppression, AKS, Analog-for-the-Digital Age, Any Capacitor, AnyIn, AnyOut, Augmented Switching, BlueSky, BodyCom, CodeGuard, CryptoAuthentication, CryptoAutomotive, CryptoCompanion, CryptoController, dsPICDEM, dsPICDEM.net, Dynamic Average Matching, DAM, ECAN, Espresso T1S, EtherGREEN, GridTime, IdealBridge, In-Circuit Serial Programming, ICSP, INICnet, Intelligent Paralleling, Inter-Chip Connectivity, JitterBlocker, Knob-on-Display, maxCrypto, maxView, memBrain, Mindi, MiWi, MPASM, MPF, MPLAB Certified logo, MPLIB, MPLINK, MultiTRAK, NetDetach, NVM Express, NVMe, Omniscient Code Generation, PICDEM, PICDEM.net, PICkit, PICtail, PowerSmart, PureSilicon, QMatrix, REAL ICE, Ripple Blocker, RTAX, RTG4, SAM-ICE, Serial Quad I/O, simpleMAP, SimpliPHY, SmartBuffer, SmartHLS, SMART-I.S., storClad, SQI, SuperSwitcher, SuperSwitcher II, Switchtec, SynchroPHY, Total Endurance, TSHARC, USBCheck, VariSense, VectorBlox, VeriPHY, ViewSpan, WiperLock, XpressConnect, and ZENA are trademarks of Microchip Technology Incorporated in the U.S.A. and other countries.

SQTP is a service mark of Microchip Technology Incorporated in the U.S.A.

The Adaptec logo, Frequency on Demand, Silicon Storage Technology, Symmcom, and Trusted Time are registered trademarks of Microchip Technology Inc. in other countries.

GestIC is a registered trademark of Microchip Technology Germany II GmbH & Co. KG, a subsidiary of Microchip Technology Inc., in other countries.

All other trademarks mentioned herein are property of their respective companies.

© 2023, Microchip Technology Incorporated and its subsidiaries.

All Rights Reserved.

ISBN: 9781668327937

For information regarding Microchip's Quality Management Systems, please visit [www.microchip.com/quality](http://www.microchip.com/quality).



---

---

## Worldwide Sales and Service

---

---

### AMERICAS

**Corporate Office**  
2355 West Chandler Blvd.  
Chandler, AZ 85224-6199  
Tel: 480-792-7200  
Fax: 480-792-7277  
Technical Support:  
[http://www.microchip.com/  
support](http://www.microchip.com/support)  
Web Address:  
[www.microchip.com](http://www.microchip.com)

#### Atlanta

Duluth, GA  
Tel: 678-957-9614  
Fax: 678-957-1455

#### Austin, TX

Tel: 512-257-3370

#### Boston

Westborough, MA  
Tel: 774-760-0087  
Fax: 774-760-0088

#### Chicago

Itasca, IL  
Tel: 630-285-0071  
Fax: 630-285-0075

#### Dallas

Addison, TX  
Tel: 972-818-7423  
Fax: 972-818-2924

#### Detroit

Novi, MI  
Tel: 248-848-4000

#### Houston, TX

Tel: 281-894-5983

#### Indianapolis

Noblesville, IN  
Tel: 317-773-8323  
Fax: 317-773-5453  
Tel: 317-536-2380

#### Los Angeles

Mission Viejo, CA  
Tel: 949-462-9523  
Fax: 949-462-9608  
Tel: 951-273-7800

#### Raleigh, NC

Tel: 919-844-7510

#### New York, NY

Tel: 631-435-6000

#### San Jose, CA

Tel: 408-735-9110  
Tel: 408-436-4270

#### Canada - Toronto

Tel: 905-695-1980  
Fax: 905-695-2078

### ASIA/PACIFIC

**Australia - Sydney**  
Tel: 61-2-9868-6733

**China - Beijing**  
Tel: 86-10-8569-7000

**China - Chengdu**  
Tel: 86-28-8665-5511

**China - Chongqing**  
Tel: 86-23-8980-9588

**China - Dongguan**  
Tel: 86-769-8702-9880

**China - Guangzhou**  
Tel: 86-20-8755-8029

**China - Hangzhou**  
Tel: 86-571-8792-8115

**China - Hong Kong SAR**  
Tel: 852-2943-5100

**China - Nanjing**  
Tel: 86-25-8473-2460

**China - Qingdao**  
Tel: 86-532-8502-7355

**China - Shanghai**  
Tel: 86-21-3326-8000

**China - Shenyang**  
Tel: 86-24-2334-2829

**China - Shenzhen**  
Tel: 86-755-8864-2200

**China - Suzhou**  
Tel: 86-186-6233-1526

**China - Wuhan**  
Tel: 86-27-5980-5300

**China - Xian**  
Tel: 86-29-8833-7252

**China - Xiamen**  
Tel: 86-592-2388138

**China - Zhuhai**  
Tel: 86-756-3210040

### ASIA/PACIFIC

**India - Bangalore**  
Tel: 91-80-3090-4444

**India - New Delhi**  
Tel: 91-11-4160-8631

**India - Pune**  
Tel: 91-20-4121-0141

**Japan - Osaka**  
Tel: 81-6-6152-7160

**Japan - Tokyo**  
Tel: 81-3-6880-3770

**Korea - Daegu**  
Tel: 82-53-744-4301

**Korea - Seoul**  
Tel: 82-2-554-7200

**Malaysia - Kuala Lumpur**  
Tel: 60-3-7651-7906

**Malaysia - Penang**  
Tel: 60-4-227-8870

**Philippines - Manila**  
Tel: 63-2-634-9065

**Singapore**  
Tel: 65-6334-8870

**Taiwan - Hsin Chu**  
Tel: 886-3-577-8366

**Taiwan - Kaohsiung**  
Tel: 886-7-213-7830

**Taiwan - Taipei**  
Tel: 886-2-2508-8600

**Thailand - Bangkok**  
Tel: 66-2-694-1351

**Vietnam - Ho Chi Minh**  
Tel: 84-28-5448-2100

### EUROPE

**Austria - Wels**  
Tel: 43-7242-2244-39  
Fax: 43-7242-2244-393

**Denmark - Copenhagen**  
Tel: 45-4485-5910  
Fax: 45-4485-2829

**Finland - Espoo**  
Tel: 358-9-4520-820

**France - Paris**  
Tel: 33-1-69-53-63-20  
Fax: 33-1-69-30-90-79

**Germany - Garching**  
Tel: 49-8931-9700

**Germany - Haan**  
Tel: 49-2129-3766400

**Germany - Heilbronn**  
Tel: 49-7131-72400

**Germany - Karlsruhe**  
Tel: 49-721-625370

**Germany - Munich**  
Tel: 49-89-627-144-0  
Fax: 49-89-627-144-44

**Germany - Rosenheim**  
Tel: 49-8031-354-560

**Israel - Ra'anana**  
Tel: 972-9-744-7705

**Italy - Milan**  
Tel: 39-0331-742611  
Fax: 39-0331-466781

**Italy - Padova**  
Tel: 39-049-7625286

**Netherlands - Drunen**  
Tel: 31-416-690399  
Fax: 31-416-690340

**Norway - Trondheim**  
Tel: 47-7288-4388

**Poland - Warsaw**  
Tel: 48-22-3325737

**Romania - Bucharest**  
Tel: 40-21-407-87-50

**Spain - Madrid**  
Tel: 34-91-708-08-90  
Fax: 34-91-708-08-91

**Sweden - Gothenberg**  
Tel: 46-31-704-60-40

**Sweden - Stockholm**  
Tel: 46-8-5090-4654

**UK - Wokingham**  
Tel: 44-118-921-5800  
Fax: 44-118-921-5820