

**PNP SILICON PLANAR SWITCHING TRANSISTORS**

**2N2906A  
2N2907A  
TO-18**

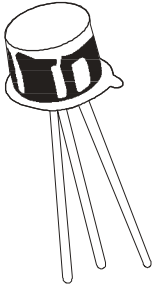

**Switching And Linear Application DC to VHF Amplifier Applications**

**ABSOLUTE MAXIMUM RATINGS**

DESCRIPTION	SYMBOL	2N2906A, 07A	UNIT
Collector -Emitter Voltage	V <sub>CEO</sub>	60	V
Collector -Base Voltage	V <sub>CBO</sub>	60	V
Emitter -Base Voltage	V <sub>EBO</sub>	5.0	V
Collector Current Continuous	I <sub>C</sub>	600	mA
Power Dissipation @Ta=25 degC	PD	400	mW
Derate Above 25deg C		2.28	mW/deg C
@ Tc=25 degC	PD	1.8	W
Derate Above 25deg C		10.3	mW/deg C
Operating And Storage Junction Temperature Range	T <sub>j</sub> , T <sub>stg</sub>	- 65 to +200	deg C

**ELECTRICAL CHARACTERISTICS (Ta=25 deg C Unless Otherwise Specified)**

DESCRIPTION	SYMBOL	TEST CONDITION	VALUE		UNIT
			MIN	MAX	
Collector -Emitter Voltage	V <sub>CEO</sub> *	IC=10mA, IB=0	60	-	V
Collector -Base Voltage	V <sub>CBO</sub>	IC=10uA, IE=0	60	-	V
Emitter-Base Voltage	V <sub>EBO</sub>	IE=10uA, IC=0	5.0	-	V
Collector-Cut off Current	I <sub>CBO</sub>	V <sub>CB</sub> =50V, IE=0	-	10	nA
		Ta=150 deg C			
		V <sub>CB</sub> =50V, IE=0	-	10	uA
	I <sub>CEX</sub>	V <sub>CE</sub> =30V, V <sub>BE</sub> =0.5V	-	50	nA
Base Current	I <sub>B</sub>	V <sub>CE</sub> =30V, V <sub>BE</sub> =0.5V	-	50	nA
Collector Emitter Saturation Voltage	V <sub>CE(Sat)</sub> *	IC=150mA, IB=15mA	-	0.4	V
		IC=500mA, IB=50mA		1.6	V
Base Emitter Saturation Voltage	V <sub>BE(Sat)</sub> *	IC=150mA, IB=15mA	-	1.3	V
		IC=500mA, IB=50mA	-	2.6	V
			<b>2N2906A</b>	<b>2N2907A</b>	
DC Current Gain	h <sub>FE</sub>	IC=0.1mA, V <sub>CE</sub> =10V	>40	>75	
		IC=1mA, V <sub>CE</sub> =10V	>40	>100	
		IC=10mA, V <sub>CE</sub> =10V	>40	>100	
		IC=150mA, V <sub>CE</sub> =10V*	40-120	100-300	
		IC=500mA, V <sub>CE</sub> =10V*	>40	>50	

**ELECTRICAL CHARACTERISTICS (Ta=25 deg C Unless Otherwise Specified)**

**2N2906A-07A**

DESCRIPTION	SYMBOL	TEST CONDITION	MIN	MAX	UNIT
<b><u>DYNAMIC CHARACTERISTICS</u></b>					
Transition Frequency	ft **	IC=50mA, VCE=20V, f=100MHz	200	-	MHz
Out-Put Capacitance	Cob	VCB=10V, IE=0, f=100kHz	-	8.0	pF
Input Capacitance	Cib	VBE=2V, IC=0, f=100kHz	-	30	pF
<b><u>Switching Time</u></b>					
Delay time	td	IC=150mA, IB1=15mA	-	10	ns
Rise time	tr	VCC=30V	-	40	ns
Turn-On Time	ton			45	ns
Storage time	ts	IC=150mA, IB1=IB2=15mA	-	80	ns
Fall time	tf	VCC=6V	-	30	ns
Turn-Off Time	toff		-	100	ns

\*Pulse Test :-Pulse Width=300us, Duty Cycle=2%

\*\*ft is defined as the frequency at which  $h_{fe}$  extrapolates to unity

**TO-18 Metal Can Package**

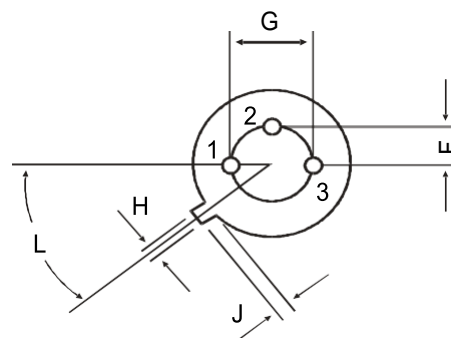
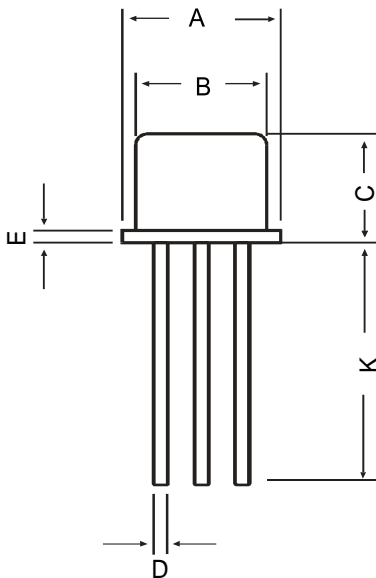

DIM	MIN	MAX
A	5.24	5.84
B	4.52	4.97
C	4.31	5.33
D	0.40	0.53
E	—	0.76
F	—	1.27
G	—	2.97
H	0.91	1.17
J	0.71	1.21
K	12.70	—
L	45 DEG	

All dimensions in mm.

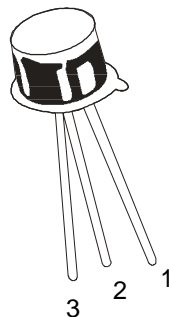

**PIN CONFIGURATION**

1. EMITTER
2. BASE
3. COLLECTOR

**Packing Detail**

PACKAGE	STANDARD PACK		INNER CARTON BOX		OUTER CARTON BOX		
	Details	Net Weight/Qty	Size	Qty	Size	Qty	Gr Wt
TO-18	1K/polybag	350 gm/1K pcs	3" x 7.5" x 7.5"	5.0K	17" x 15" x 13.5"	80.0K	34 kgs

## Notes

### Disclaimer

The product information and the selection guides facilitate selection of the CDIL's Discrete Semiconductor Device(s) best suited for application in your product(s) as per your requirement. It is recommended that you completely review our Data Sheet(s) so as to confirm that the Device(s) meet functionality parameters for your application. The information furnished on the CDIL Web Site/CD is believed to be accurate and reliable. CDIL however, does not assume responsibility for inaccuracies or incomplete information. Furthermore, CDIL does not assume liability whatsoever, arising out of the application or use of any CDIL product; neither does it convey any license under its patent rights nor rights of others. These products are not designed for use in life saving/support appliances or systems. CDIL customers selling these products (either as individual Discrete Semiconductor Devices or incorporated in their end products), in any life saving/support appliances or systems or applications do so at their own risk and CDIL will not be responsible for any damages resulting from such sale(s).

CDIL strives for continuous improvement and reserves the right to change the specifications of its products without prior notice.



CDIL is a registered Trademark of  
Continental Device India Limited