

## NPN EPITAXIAL SILICON POWER TRANSISTORS

**BD135 BD137  
BD139**

**TO126  
Plastic Package**

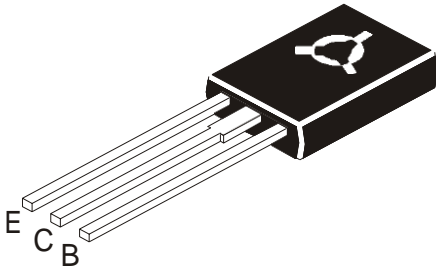

Designed for use as Audio Amplifier and Drivers Utilizing

Complementary BD136, BD138, BD140

### ABSOLUTE MAXIMUM RATINGS

DESCRIPTION	SYMBOL	BD135	BD137	BD139	UNIT
Collector -Emitter Voltage	$V_{CEO}$	45	60	80	V
Collector -Emitter Voltage ( $R_{BE}=1kW$ )	$V_{CER}$	45	60	100	V
Collector -Base Voltage	$V_{CBO}$	45	60	100	V
Emitter Base Voltage	$V_{EBO}$	5.0			V
Collector Current	$I_C$	1.5			A
Collector Peak Current	$I_{CM}$	2.0			A
Base Current	$I_B$	0.5			A
Power Dissipation @ $T_a=25^{\circ}C$ Derate above $25^{\circ}C$	$P_D$	1.25 10			W mW/ $^{\circ}C$
Power Dissipation @ $T_c=25^{\circ}C$ Derate above $25^{\circ}C$	$P_D$	12.5 100			W mW/ $^{\circ}C$
Power Dissipation @ $T_c=70^{\circ}C$	$P_D$	8.0			W
Operating And Storage Junction Temperature Range	$T_j, T_{stg}$	- 55 to +150			$^{\circ}C$

### THERMAL CHARACTERISTICS

Junction to Ambient in free air	$R_{th(j-a)}$	100	$^{\circ}C/W$
Junction to Case	$R_{th(j-c)}$	10	$^{\circ}C/W$

### ELECTRICAL CHARACTERISTICS ( $T_c=25^{\circ}C$ unless specified otherwise)

DESCRIPTION	SYMBOL	TEST CONDITION	MIN	MAX	UNIT
Collector Emitter Sustaining Voltage	$*V_{CEO(sus)}$	$I_C=30mA, I_B=0$ <b>BD135</b> <b>BD137</b> <b>BD139</b>	45 60 80		V V V
Collector Cut off Current	$I_{CBO}$	$V_{CB}=30V, I_E=0$		0.1	$\mu A$
		$V_{CB}=30V, I_E=0,$ $T_c=125^{\circ}C$		10	$\mu A$
Emitter Cut off Current	$I_{EBO}$	$V_{EB}=5V, I_C=0$		10	$\mu A$
DC Current Gain	$*h_{FE}$	$I_C=0.005A, V_{CE}=2V$	25		
		$I_C=0.15A, V_{CE}=2V$	40	250	
		$I_C=0.5A, V_{CE}=2V$	25		

\*Pulse test:- Pulse width=300ms, duty cycle=2%

# NPN EPITAXIAL SILICON POWER TRANSISTORS

**BD135 BD137  
BD139**

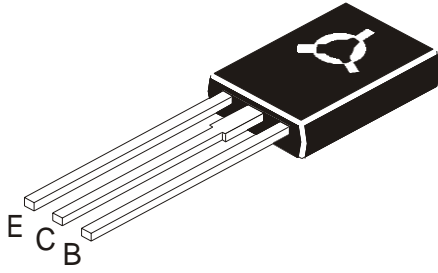

**TO126  
Plastic Package**

## ELECTRICAL CHARACTERISTICS (T<sub>c</sub>=25°C unless specified otherwise)

DESCRIPTION	SYMBOL	TEST CONDITION	MIN	MAX	UNIT
DC Current Gain	*h <sub>FE</sub> Group	I <sub>C</sub> =0.15A, V <sub>CE</sub> =2V			
		- 6	40	100	
		- 10	63	160	
		- 16	100	250	
		- 25	160	400	
Collector Emitter Saturation Voltage	*V <sub>CE(sat)</sub>	I <sub>C</sub> =0.5A, I <sub>B</sub> =0.05A		0.5	V
Base Emitter On Voltage	*V <sub>BE(on)</sub>	*I <sub>C</sub> =0.5A, V <sub>CE</sub> =2V		1.0	V

\*Pulse test:- Pulse width=300ms, duty cycle=2%

TO126  
Plastic Package

TO-126  
Leaded Plastic  
Package

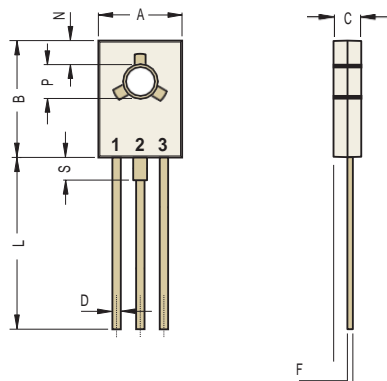
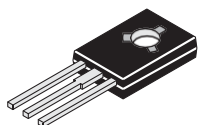

DIM	Min	Max	DIM	Min	Max
A	7.12	8.38	G	4.07	5.08
B	10.16	11.43	L	15.00	16.63
C	2.29	3.04	M	0.89	1.65
D	0.64	0.88	N	3.31	4.44
E	2.040	2.285	P	2.54	3.30
F	0.39	0.63	S	—	2.54

Pin Configurations

Pin 1: Emitter Pin 2: Collector Pin 3: Base

TO-126 Series Packaging Tube

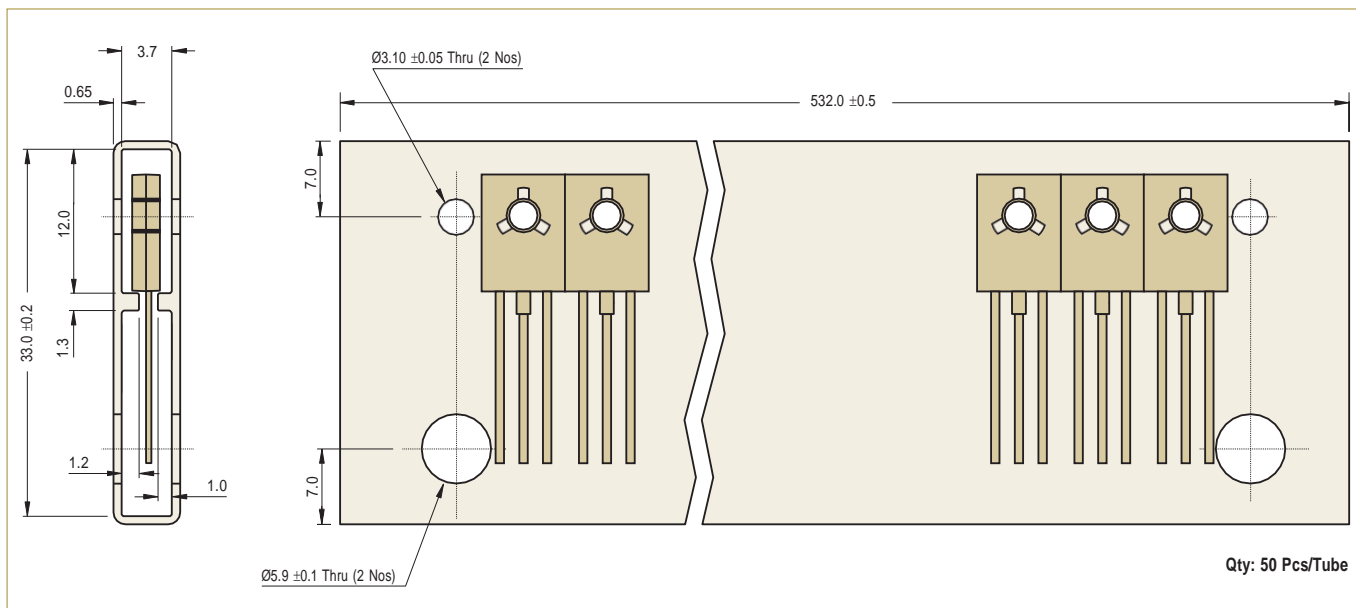

Qty: 50 Pcs/Tube

Packaging Specifications ...

T & A: Tape and Ammo Pack; T & R: Tape and Reel; Bulk: Loose in Poly Bags; Tube: Tube and Carton; K: 1,000

Package / Case Type	Packaging Type	Std. Packing		Inner Carton		Outer Carton		
		Qty	Qty	Size L x W x H (cm)	Gross Weight (Kg)	Qty	Size L x W x H (cm)	Gross Weight (Kg)
TO-126	Bulk	2,000	2K	19 x 19 x 8	1.4	20K	46 x 38 x 22	15.6
	Tube	1,000 (50 pcs/tube)	1K	55 x 8 x 10	1.5	10K	55 x 35 x 27	16.3

**Component Disposal Instructions**

1. CDIL Semiconductor Devices are RoHS compliant, customers are requested to please dispose as per prevailing Environmental Legislation of their Country.
2. In Europe, please dispose as per EU Directive 2002/96/EC on Waste Electrical and Electronic Equipment (WEEE).

**Disclaimer**

The product information and the selection guides facilitate selection of the CDIL's Semiconductor Device(s) best suited for application in your product(s) as per your requirement. It is recommended that you completely review our Data Sheet(s) so as to confirm that the Device(s) meet functionality parameters for your application. The information furnished in the Data Sheet and on the CDIL Web Site/CD are believed to be accurate and reliable. CDIL however, does not assume responsibility for inaccuracies or incomplete information. Furthermore, CDIL does not assume liability whatsoever, arising out of the application or use of any CDIL product; neither does it convey any license under its patent rights nor rights of others. These products are not designed for use in life saving/support appliances or systems. CDIL customers selling these products (either as individual Semiconductor Devices or incorporated in their end products), in any life saving/support appliances or systems applications do so at their own risk and CDIL will not be responsible for any damages resulting from such sale(s).

CDIL strives for continuous improvement and reserves the right to change the specifications of its products without prior notice.



CDIL is a registered Trademark of  
Continental Device India Limited