

6.0 A Single-Phase Silicon Bridge Rectifier

Rectifier Reverse Voltage 50 to 1000V

Features

- This series is UL listed under the Recognized Component Index, file number E142814
- High temperature metallurgically bonded internal rectifiers
- Typical I_R less than $.1 \mu A$
- The plastic material used carries Underwriters Laboratory flammability recognition 94V-0
- High temperature soldering guaranteed 265°C/10 seconds at 5 lbs (2.3kg) tension

Mechanical Data

Case: Void-free plastic package
 Terminals: Plated leads solderable per MIL-STD-202, Method 208
 Mounting: Thru hole for #6 screw
 Mounting position: Any
 Weight: 3.8 grams (approx)

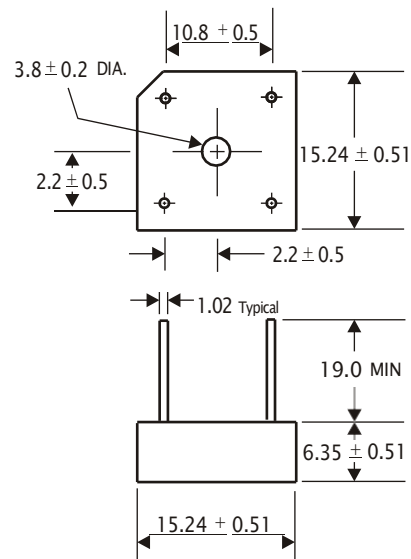

Dimensions in millimeters(1mm = 0.0394")

Maximum Ratings & Thermal Characteristics

Rating at 25°C ambient temperature unless otherwise specified, Resistive or Inductive load, 60 Hz.
 For Capacitive load derate current by 20%.

Parameter	Symbol	KBPC 6005	KBPC 601	KBPC 602	KBPC 604	KBPC 606	KBPC 608	KBPC 610	unit
Maximum repetitive peak reverse voltage	VRRM	50	100	200	400	600	800	1000	V
Maximum RMS bridge input voltage	VRMS	35	70	140	280	420	560	700	V
Maximum DC blocking voltage	VDC	50	100	200	400	600	800	1000	V
Maximum average forward rectified output current T _c = 75°C (1)	IF(AV)	6.0							A
Peak forward surge current single sine-wave superimposed on rated load (JEDEC Method)	IFSM	125							A
Rating for fusing (t<8.3ms)	I ² t	10							A ² sec
Typical thermal resistance per element (2)	ReJA	9.4							°C/W
Typical junction capacitance per element(3)	Cj	55							pF
Operating junction and storage temperature range	TJ, TSTG	-55 to + 150							°C

Electrical Characteristics

Rating at 25°C ambient temperature unless otherwise specified. Resistive or Inductive load, 60Hz.
 For Capacitive load derate by 20 %.

Parameter	Symbol	KBPC 6005	KBPC 601	KBPC 602	KBPC 604	KBPC 606	KBPC 608	KBPC 610	Unit
Maximum instantaneous forward voltage drop per leg at 3.0A	VF	1.1							V
Maximum DC reverse current at rated TA = 25°C DC blocking voltage per element TA = 100°C	IR	10 1000							μA

- Notes:** (1) Mounted on metal chassis.
 (2) Non-repetitive, for t>1ms and < 8.3ms.
 (3) Measured at 1.0MHz and applied reverse voltage of 4.0V DC.

Rating and Characteristic Curves (TA=25 °C Unless otherwise noted)

Fig. 1 Derating Curve for Output Rectified Current

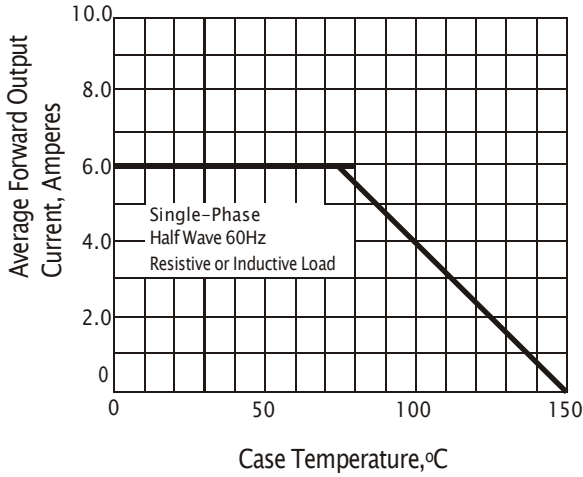

Fig. 2 Maximum Non-repetitive Peak Forward Surge Current

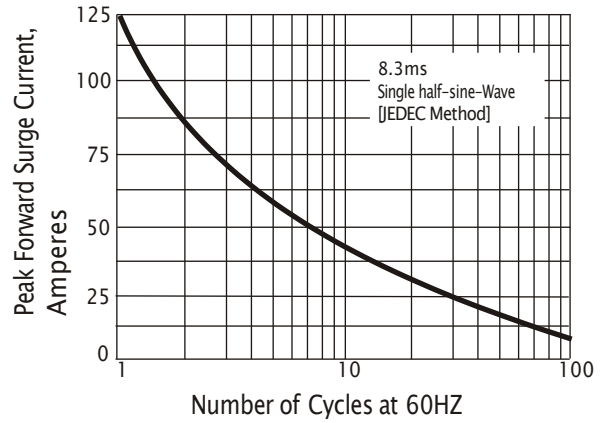

Fig. 3 Typical Instantaneous Forward Characteristics

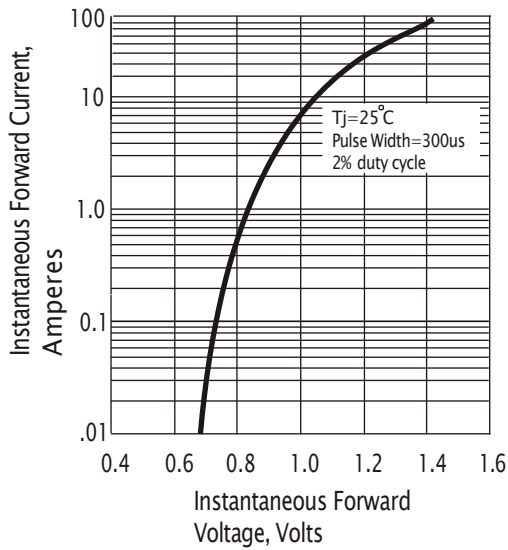

Fig. 4 Typical Reverse Characteristics

