

10 A Single-Phase Silicon Bridge Rectifier

Rectifier Reverse Voltage 50 to 1000V

Features

- Ideal for P.C. Board mounting
- High surge current capability
- This series is UL listed under the Recognized Component Index, file number E142814
- The plastic material used carries Underwriters Laboratory flammability recognition 94V-0
- High temperature soldering guaranteed 265 C /10 seconds at 5 lbs (2.3kg) tension

Mechanical Data

Case: Molded plastic body

Terminals: Plated leads solderable per MIL-STD-202, Method 208

Polarity: Polarity symbols molded on body

Mounting Position:: Any

Mounting Torque: 5 in-lbs max.

Weight: 0.3 ounce, 8.0 grams (approx)

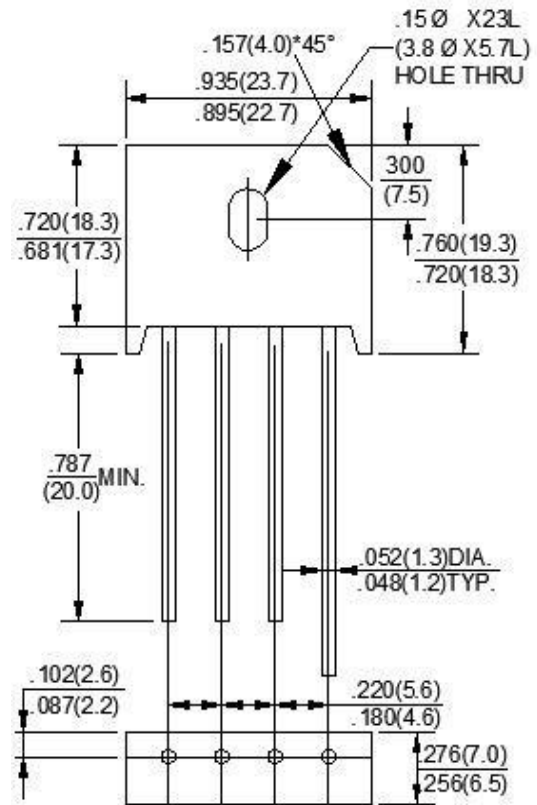

Package: KBU

Maximum Ratings & Thermal Characteristics

Rating at 25°C ambient temperature unless otherwise specified, Resistive or Inductive load, 60 Hz.

For Capacitive load derate current by 20%.

Parameter	Symbol	KBU 10005	KBU 1001	KBU 1002	KBU 1004	KBU 1006	KBU 1008	KBU 1010	unit
Maximum repetitive peak reverse voltage	VRRM	50	100	200	400	600	800	1000	V
Maximum RMS bridge input voltage	VRMS	35	70	140	280	420	560	700	V
Maximum DC blocking voltage	VDC	50	100	200	400	600	800	1000	V
Maximum average forward rectified output current at TA=100°C	IF(AV)	10							A
Peak forward surge current single sine-wave superimposed on rated load (JEDEC Method)	IFSM	300							A
Rating for fusing (t<8.3ms)	I ² t	300							A ² sec
Typical thermal resistance per element (1)	ReJA	2.7							°C / W
Operating junction and storage temperature range	TJ, TSTG	-55 to + 150							°C

Electrical Characteristics

Rating at 25°C ambient temperature unless otherwise specified. Resistive or Inductive load, 60Hz.

For Capacitive load derate by 20 %.

Parameter	Symbol	KBU 10005	KBU 1001	KBU 1002	KBU 1004	KBU 1006	KBU 1008	KBU 1010	Unit
Maximum instantaneous forward voltage drop per leg at 10A	VF	1.05							V
Maximum DC reverse current at rated TA =25 °C DC blocking voltage per element TA =125°C	IR	10 500							µA

Notes: (1)Thermal resistance from Junction to Ambient on P.C.board mounting.

10 A Single-Phase Silicon Bridge Rectifier

Rating and Characteristic Curves (TA=25°C Unless otherwise noted)

Fig. 1 Derating Curve for Output Rectified Current

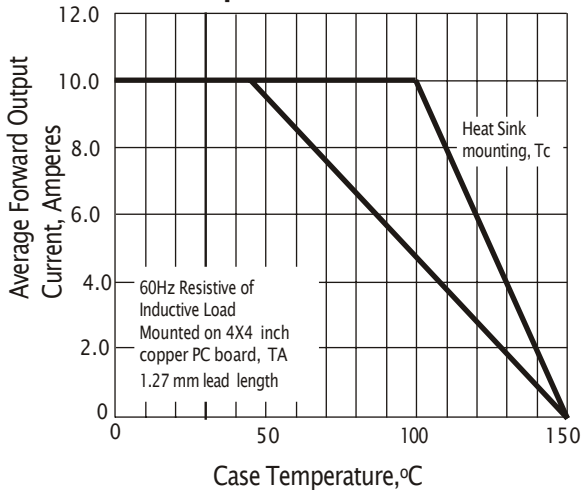

Fig. 2 Maximum Non-repetitive Peak Forward Surge Current

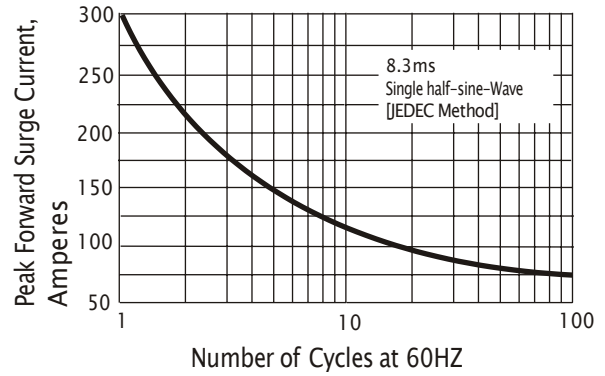

Fig. 3 Typical Instantaneous Forward Characteristics

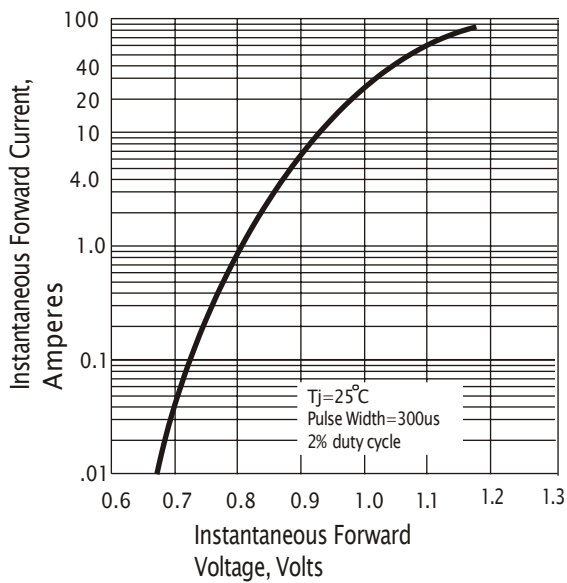

Fig. 4 Typical Reverse Characteristics

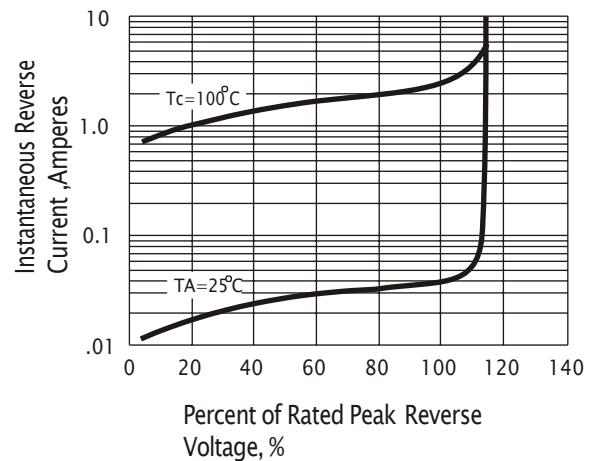

Fig. 5 Typical Junction Capacitance

