

LM138 and LM338 5-Amp Adjustable Regulators

1 Features

- Specified 7-A Peak Output Current
- Specified 5-A Output Current
- Adjustable Output Down to 1.2 V
- Specified Thermal Regulation
- Current Limit Constant With Temperature
- P⁺ Product Enhancement Tested
- Output is Short-Circuit Protected

2 Applications

- Adjustable Power Supplies
- Constant Current Regulators
- Battery Chargers

Available Packages

Pin 1. Adjustment
2. Output
3. Input
Tab/Case is Output

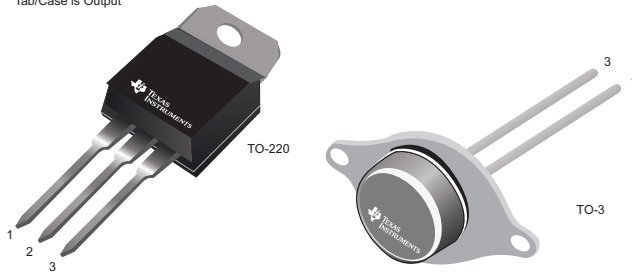

Typical Application Circuit

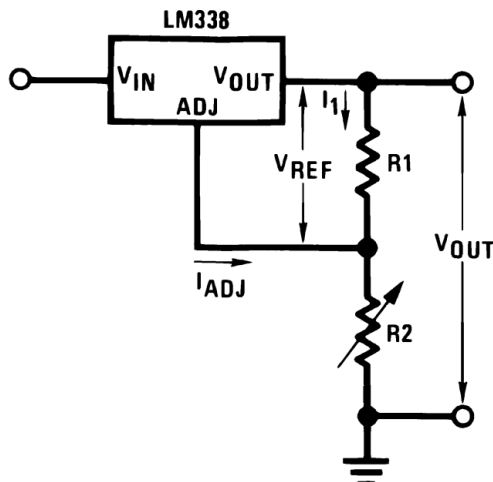

Copyright © 2016, Texas Instruments Incorporated

3 Description

The LM138 series of adjustable 3-terminal positive voltage regulators is capable of supplying in excess of 5 A over a 1.2-V to 32-V output range. They are exceptionally easy to use and require only 2 resistors to set the output voltage. Careful circuit design has resulted in outstanding load and line regulation, comparable to many commercial power supplies. The LM138 family is supplied in a standard 3-lead transistor package.

A unique feature of the LM138 family is time-dependent current limiting. The current limit circuitry allows peak currents of up to 12 A to be drawn from the regulator for short periods of time. This allows the LM138 to be used with heavy transient loads and speeds start-up under full-load conditions. Under sustained loading conditions, the current limit decreases to a safe value protecting the regulator. Also included on the chip are thermal overload protection and safe area protection for the power transistor. Overload protection remains functional even if the adjustment (ADJ) pin is accidentally disconnected.

Normally, no capacitors are needed unless the device is situated more than 6 inches from the input filter capacitors in which case an input bypass is needed. An output capacitor can be added to improve transient response, while bypassing the adjustment pin increases the ripple rejection of the regulator.

Besides replacing fixed regulators or discrete designs, the LM138 is useful in a wide variety of other applications. Because the regulator is floating and receives only the input-to-output differential voltage, supplies of several hundred volts can be regulated as long as the maximum input to output differential is not exceeded; do not short-circuit output to ground. The part numbers in the LM138 series which have a *K* suffix are packaged in a standard steel TO-CAN package, while those with a *T* suffix are packaged in a TO-220 plastic package. The LM138 is rated for $T_J = -55^{\circ}\text{C}$ to 150°C , and the LM338 is rated for $T_J = 0^{\circ}\text{C}$ to 125°C .

Device Information⁽¹⁾

PART NUMBER	PACKAGE	BODY SIZE (NOM)
LM138	TO-CAN (2)	25.40 mm × 38.94 mm
LM338	TO-220 (3)	10.16 mm × 14.986 mm
	TO-CAN (2)	25.40 mm × 38.94 mm

(1) For all available packages, see the orderable addendum at the end of the data sheet.



Table of Contents

1 Features	1	8 Application and Implementation	11
2 Applications	1	8.1 Application Information.....	11
3 Description	1	8.2 Typical Applications	12
4 Revision History	2	8.3 System Examples	17
5 Pin Configuration and Functions	3	9 Power Supply Recommendations	23
6 Specifications	3	10 Layout	23
6.1 Absolute Maximum Ratings	3	10.1 Layout Guidelines	23
6.2 Recommended Operating Conditions.....	3	10.2 Layout Example	23
6.3 Thermal Information	4	11 Device and Documentation Support	24
6.4 Electrical Characteristics: LM138.....	4	11.1 Receiving Notification of Documentation Updates	24
6.5 Electrical Characteristics: LM338.....	5	11.2 Related Links	24
6.6 Typical Characteristics	6	11.3 Community Resources.....	24
7 Detailed Description	9	11.4 Trademarks	24
7.1 Overview	9	11.5 Electrostatic Discharge Caution.....	24
7.2 Functional Block Diagram	9	11.6 Glossary	24
7.3 Feature Description.....	9	12 Mechanical, Packaging, and Orderable	
7.4 Device Functional Modes.....	10	Information	24

4 Revision History

NOTE: Page numbers for previous revisions may differ from page numbers in the current version.

Changes from Revision B (April 2013) to Revision C	Page
• Added <i>Device Information</i> table, <i>Pin Configuration and Functions</i> section, <i>Specifications</i> section, <i>Recommended Operating Conditions</i> table, <i>Thermal Information</i> table, <i>Detailed Description</i> section, <i>Application and Implementation</i> section, <i>Power Supply Recommendations</i> section, <i>Layout</i> section, <i>Device and Documentation Support</i> section, and <i>Mechanical, Packaging, and Orderable Information</i> section	1
• Deleted RETS138K military specification reference from <i>Absolute Maximum Ratings</i> table.....	3
• Changed Junction to Ambient, $R_{\theta JA}$, value in <i>Thermal Information</i> table From: 50°C/W To: 22.9°C/W (NDE)	4
• Changed Junction to Case, $R_{\theta JC(top)}$, value in <i>Thermal Information</i> table From: 4°C/W To: 15.7°C/W (NDE).....	4

Changes from Revision A (April 2013) to Revision B	Page
• Changed layout of National Semiconductor Data Sheet to TI format	1

5 Pin Configuration and Functions

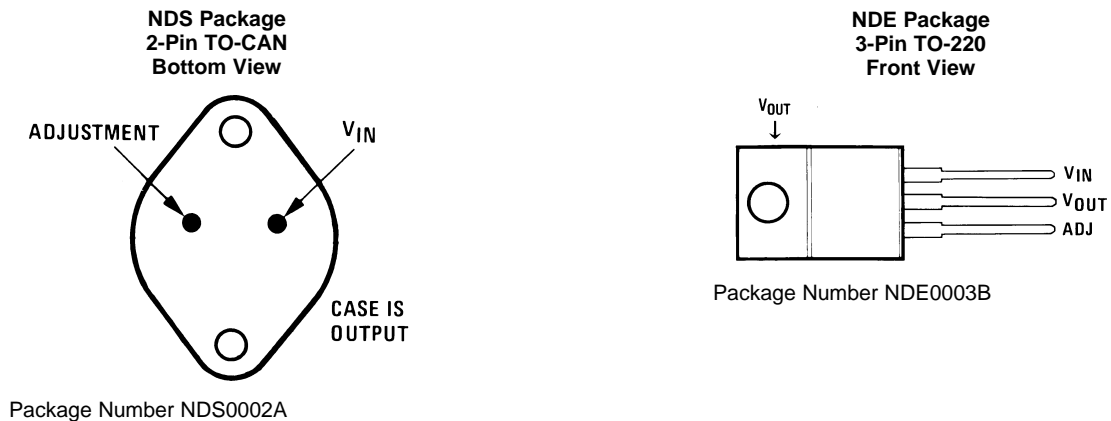

Pin Functions

NAME	PIN		I/O	DESCRIPTION
	TO-220	TO-CAN		
ADJ	1	1	I	Output voltage adjustment pin. Connect to a resistor divider to set V_O
V_{IN}	3	2	I	Supply input pin
V_{OUT}	2	Case	O	Voltage output pin

6 Specifications

6.1 Absolute Maximum Ratings

over operating free-air temperature range (unless otherwise noted)⁽¹⁾

	MIN	MAX	UNIT	
Input and output voltage differential	-0.3	40	V	
Power dissipation	Internally limited			
Lead temperature	TO-3 package (soldering, 10 s)		°C	
	TO-220 package (soldering, 4 s)			
Operating temperature, T_J	LM138	-55	150	°C
	LM338	0	125	
Storage temperature, T_{stg}	-65	150	°C	

(1) Stresses beyond those listed under *Absolute Maximum Ratings* may cause permanent damage to the device. These are stress ratings only, which do not imply functional operation of the device at these or any other conditions beyond those indicated under *Recommended Operating Conditions*. Exposure to absolute-maximum-rated conditions for extended periods may affect device reliability.

6.2 Recommended Operating Conditions

over operating free-air temperature range (unless otherwise noted)

	MIN	MAX	UNIT
Input-to-output voltage differential	3	40	V
Output current		5	A

6.3 Thermal Information

THERMAL METRIC ⁽¹⁾	LM338		LM338		UNIT
	NDS (TO-CAN)	NDE (TO-220)	NDS (TO-CAN)		
	2 PINS	3 PINS	2 PINS		
R _{θJA} Junction-to-ambient thermal resistance	35	22.9	35		°C/W
R _{θJC(top)} Junction-to-case (top) thermal resistance	1	15.7	1		°C/W
R _{θJB} Junction-to-board thermal resistance	—	4.1	—		°C/W
ψ _{JT} Junction-to-top characterization parameter	—	2.1	—		°C/W
ψ _{JB} Junction-to-board characterization parameter	—	4.1	—		°C/W
R _{θJC(bot)} Junction-to-case (bottom) thermal resistance	—	0.7	—		°C/W

(1) For more information about traditional and new thermal metrics, see the [Semiconductor and IC Package Thermal Metrics](#) application report.

6.4 Electrical Characteristics: LM138

Values apply for T_J = 25°C; V_{IN} – V_{OUT} = 5 V; and I_{OUT} = 10 mA (unless otherwise noted).⁽¹⁾

PARAMETER	TEST CONDITIONS	MIN	TYP	MAX	UNIT
V _{REF} Reference voltage	3 V ≤ (V _{IN} – V _{OUT}) ≤ 35 V, 10 mA ≤ I _{OUT} ≤ 5 A, P ≤ 50 W, T _J = –55°C to 150°C	1.19	1.24	1.29	V
V _{RLINE} Line regulation	3 V ≤ (V _{IN} – V _{OUT}) ≤ 35 V ⁽²⁾	T _J = 25°C		0.005%	0.01%
		T _J = –55°C to 150°C		0.02%	0.04%
V _{RLOAD} Load regulation	10 mA ≤ I _{OUT} ≤ 5 A ⁽²⁾	T _J = 25°C		0.1%	0.3%
		T _J = –55°C to 150°C		0.3%	0.6%
Thermal regulation	20 ms pulse		0.002%	0.01%	W
I _{ADJ} Adjustment pin current	T _J = –55°C to 150°C		45	100	μA
ΔI _{ADJ} Adjustment pin current change	10 mA ≤ I _{OUT} ≤ 5 A, 3 V ≤ (V _{IN} – V _{OUT}) ≤ 35 V, T _J = –55°C to 150°C		0.2	5	μA
ΔV _{R/T} Temperature stability	T _J = –55°C to 150°C		1%		
I _{LOAD(MIN)} Minimum load current	V _{IN} – V _{OUT} = 35 V, T _J = –55°C to 150°C		3.5	5	mA
I _{CL} Current limit	V _{IN} – V _{OUT} ≤ 10 V				
	DC, T _J = –55°C to 150°C	5	8		A
	0.5-ms peak, T _J = –55°C to 150°C	7	12		A
	V _{IN} – V _{OUT} = 30 V		1	1	A
V _N RMS output noise (percent of V _{OUT})	10 Hz ≤ f ≤ 10 kHz		0.003%		
ΔV _R /ΔV _{IN} Ripple rejection ratio	V _{OUT} = 10 V, f = 120 Hz, C _{ADJ} = 0 μF, T _J = –55°C to 150°C		60		dB
	V _{OUT} = 10 V, f = 120 Hz, C _{ADJ} = 10 μF, T _J = –55°C to 150°C	60	75		dB
Long-term stability	T _J = 125°C, 1000 Hrs		0.3%	1%	

- (1) These specifications are applicable for power dissipations up to 50 W for the TO-3 (NDS) package and 25 W for the TO-220 (NDE) package. Power dissipation is specified at these values up to 15-V input-output differential. Above 15-V differential, power dissipation is limited by internal protection circuitry. All limits (that is, the numbers in the minimum and maximum columns) are specified to TI's AOQL (Average Outgoing Quality Level).
- (2) Regulation is measured at a constant junction temperature, using pulse testing with a low duty cycle. Changes in output voltage due to heating effects are covered under the specifications for thermal regulation.

6.5 Electrical Characteristics: LM338

Values apply for $T_J = 25^\circ\text{C}$; $V_{IN} - V_{OUT} = 5\text{ V}$; and $I_{OUT} = 10\text{ mA}$ (unless otherwise noted).⁽¹⁾

PARAMETER		TEST CONDITIONS	MIN	TYP	MAX	UNIT	
V_{REF}	Reference voltage	$3\text{ V} \leq (V_{IN} - V_{OUT}) \leq 35\text{ V}$, $10\text{ mA} \leq I_{OUT} \leq 5\text{ A}$, $P \leq 50\text{ W}$, $T_J = 0^\circ\text{C}$ to 125°C	1.19	1.24	1.29	V	
V_{RLINE}	Line regulation	$3\text{ V} \leq (V_{IN} - V_{OUT}) \leq 35\text{ V}^{(2)}$	$T_J = 25^\circ\text{C}$		0.005%	0.03%	V
			$T_J = 0^\circ\text{C}$ to 125°C		0.02%	0.06%	V
V_{RLOAD}	Load regulation	$10\text{ mA} \leq I_{OUT} \leq 5\text{ A}^{(2)}$	$T_J = 25^\circ\text{C}$		0.1	0.5	
			$T_J = 0^\circ\text{C}$ to 125°C		0.3	1	
	Thermal regulation	20-ms pulse		0.002%	0.02%	W	
I_{ADJ}	Adjustment pin current	$T_J = 0^\circ\text{C}$ to 125°C		45	100	μA	
ΔI_{ADJ}	Adjustment pin current change	$10\text{ mA} \leq I_{OUT} \leq 5\text{ A}$, $3\text{ V} \leq (V_{IN} - V_{OUT}) \leq 35\text{ V}$, $T_J = 0^\circ\text{C}$ to 125°C		0.2	5	μA	
ΔV_{RT}	Temperature stability	$T_J = 0^\circ\text{C}$ to 125°C		1			
$I_{LOAD(MIN)}$	Minimum load current	$V_{IN} - V_{OUT} = 35\text{ V}$, $T_J = 0^\circ\text{C}$ to 125°C		3.5	10	mA	
I_{CL}	Current limit	$V_{IN} - V_{OUT} \leq 10\text{ V}$					
		DC, $T_J = 0^\circ\text{C}$ to 125°C	5	8	A		
		0.5-ms peak, $T_J = 0^\circ\text{C}$ to 125°C	7	12	A		
		$V_{IN} - V_{OUT} = 30\text{ V}$			1	A	
V_N	RMS output noise (percent of V_{OUT})	$10\text{ Hz} \leq f \leq 10\text{ kHz}$		0.003%			
$\Delta V_R/\Delta V_{IN}$	Ripple rejection ratio	$V_{OUT} = 10\text{ V}$, $f = 120\text{ Hz}$, $C_{ADJ} = 0\text{ }\mu\text{F}$, $T_J = 0^\circ\text{C}$ to 125°C		60		dB	
		$V_{OUT} = 10\text{ V}$, $f = 120\text{ Hz}$, $C_{ADJ} = 10\text{ }\mu\text{F}$, $T_J = 0^\circ\text{C}$ to 125°C	60	75		dB	
	Long-term stability	$T_J = 125^\circ\text{C}$, 1000 Hrs		0.3%	1%		

- (1) These specifications are applicable for power dissipations up to 50 W for the TO-3 (NDS) package and 25 W for the TO-220 (NDE) package. Power dissipation is specified at these values up to 15-V input-output differential. Above 15-V differential, power dissipation is limited by internal protection circuitry. All limits (that is, the numbers in the minimum and maximum columns) are specified to TI's AOQL (Average Outgoing Quality Level).
- (2) Regulation is measured at a constant junction temperature, using pulse testing with a low duty cycle. Changes in output voltage due to heating effects are covered under the specifications for thermal regulation.

6.6 Typical Characteristics

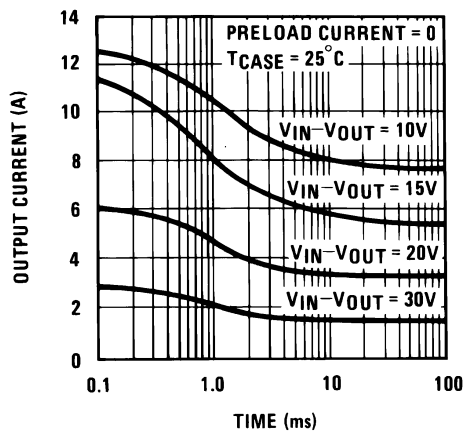

Figure 1. Current Limit

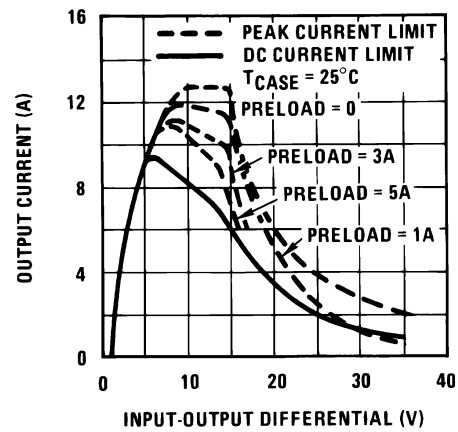

Figure 2. Current Limit

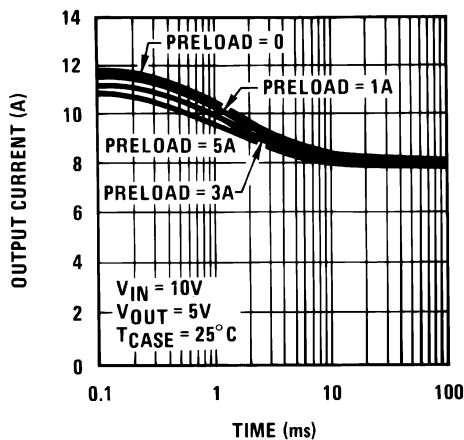

Figure 3. Current Limit

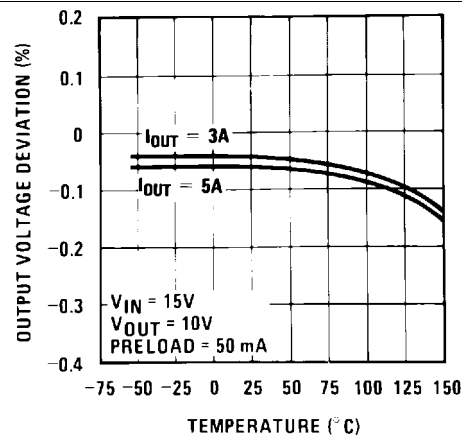

Figure 4. Load Regulation

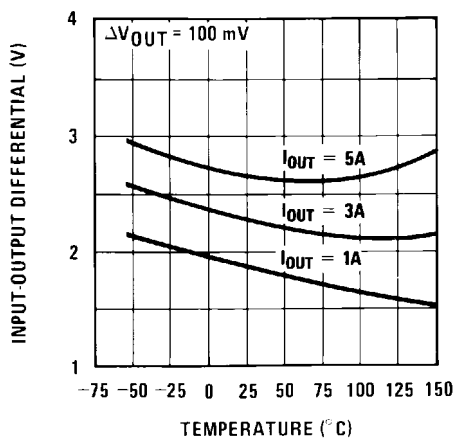

Figure 5. Dropout Voltage

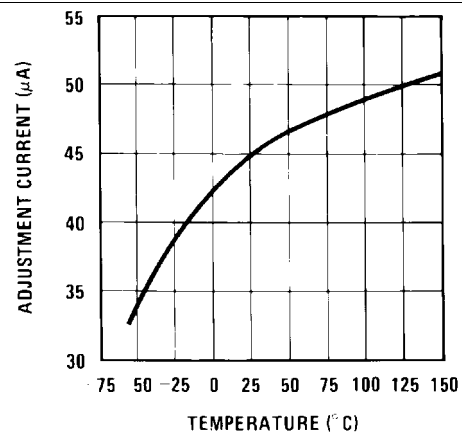

Figure 6. Adjustment Current

Typical Characteristics (continued)

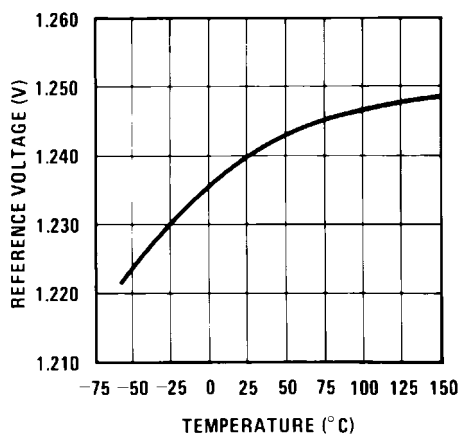

Figure 7. Temperature Stability

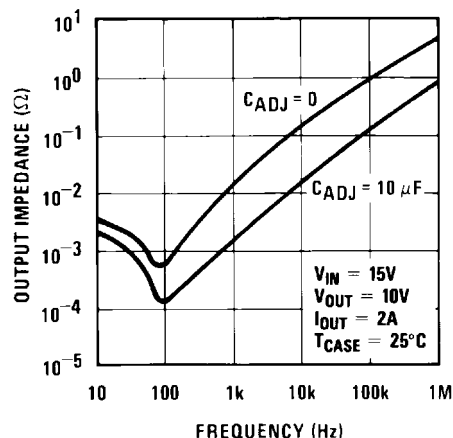

Figure 8. Output Impedance

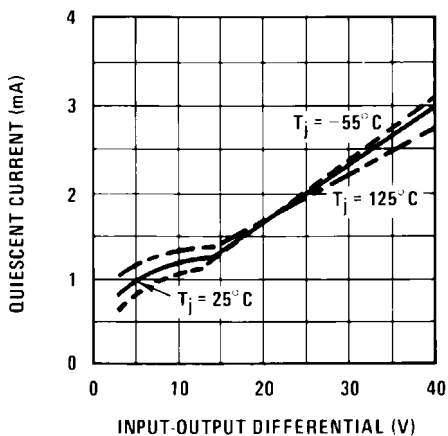

Figure 9. Minimum Operating Current

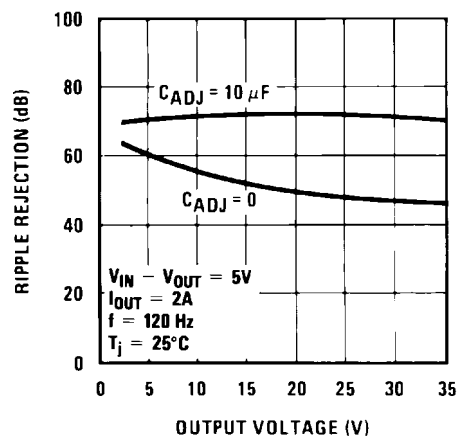

Figure 10. Ripple Rejection

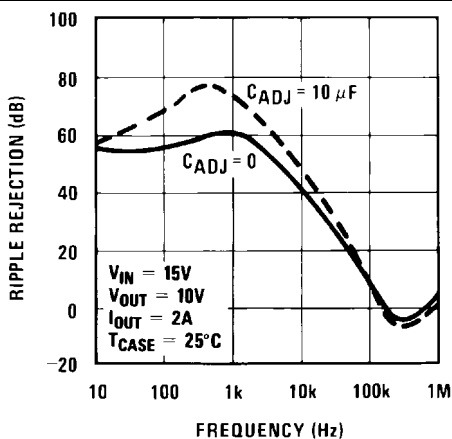

Figure 11. Ripple Rejection

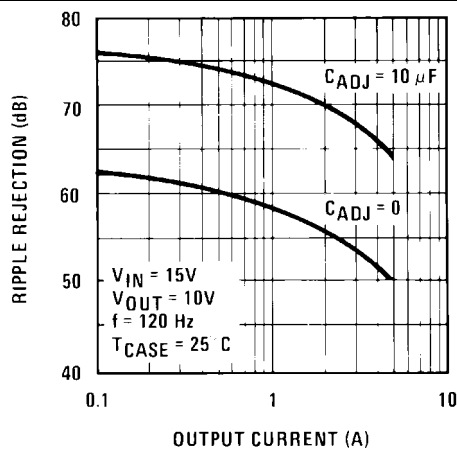
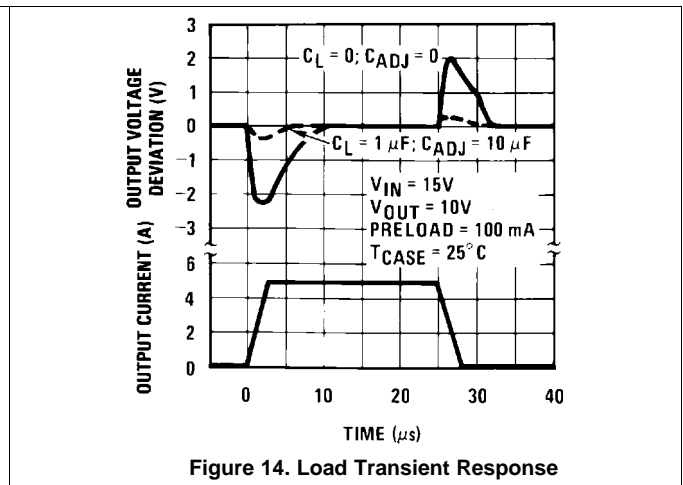
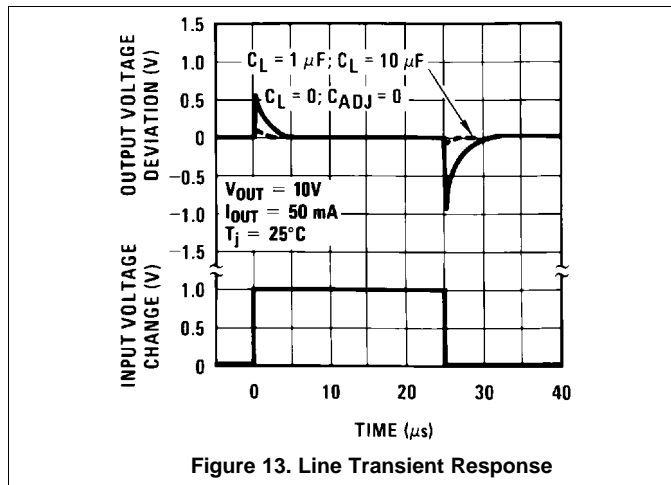

Figure 12. Ripple Rejection

Typical Characteristics (continued)



7 Detailed Description

7.1 Overview

The LM138 and LM338 devices are adjustable, three-terminal, positive-voltage regulators capable of supplying more than 5 A over an output-voltage range of 1.2 V to 32 V. It requires only two external resistors to set the output voltage. These devices feature a typical line regulation of 0.005% and typical load regulation of 0.1%. It includes time-dependent current limiting, thermal overload protection, and safe operating area protection. Overload protection remains functional even if the ADJUST terminal is disconnected.

The LM138 and LM338 devices are versatile in their applications, including uses in programmable output regulation and local on-card regulation. Or, by connecting a fixed resistor between the ADJUST and OUTPUT terminals, the LM138 and LM338 devices can function as a precision current regulators. An optional output capacitor can be added to improve transient response. The ADJUST terminal can be bypassed to achieve very high ripple-rejection ratios, which are difficult to achieve with standard three-terminal regulators.

7.2 Functional Block Diagram

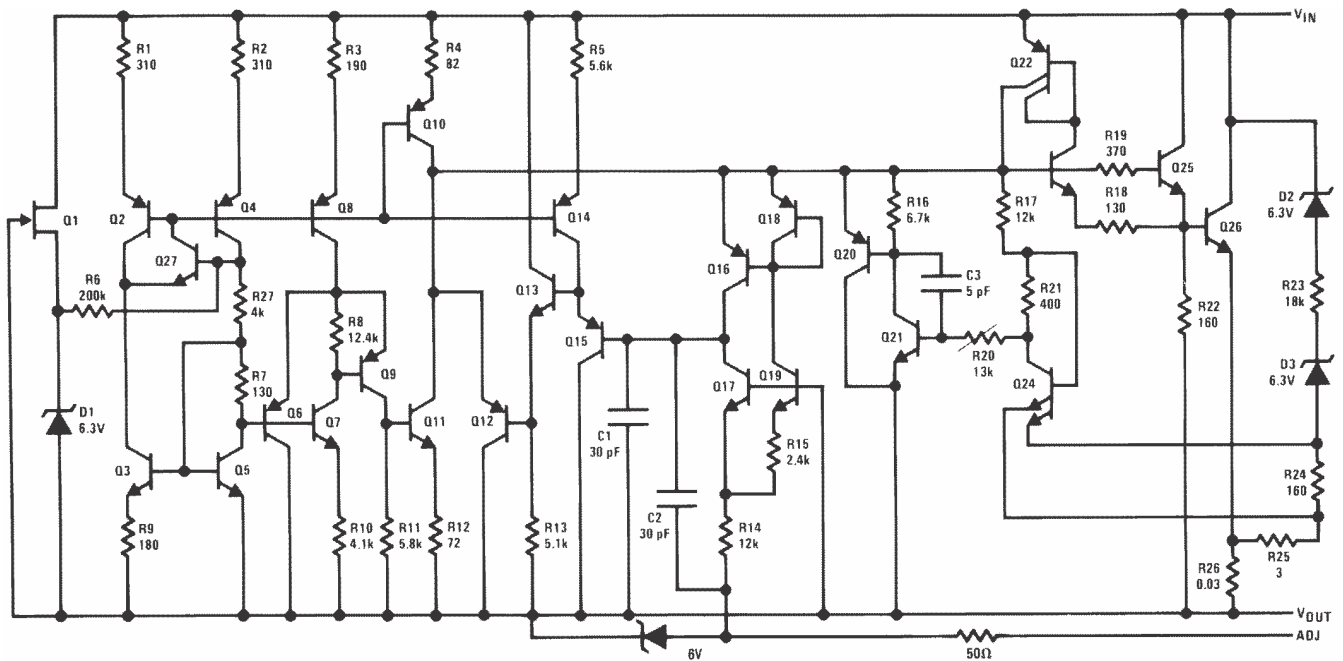

Copyright © 2016, Texas Instruments Incorporated

7.3 Feature Description

7.3.1 NPN Darlington Output Drive

NPN Darlington output topology provides naturally low output impedance and an output capacitor is optional. To support maximum current and lowest temperature, 3-V headroom is recommended ($V_I - V_O$).

7.3.2 Overload Block

Overcurrent and overtemperature shutdown protects the device against overload or damage from operating in excessive heat.

7.3.3 Programmable Feedback

Op amp with 1.25-V offset input at the ADJUST terminal provides easy output voltage or current (not both) programming. For current regulation applications, a single resistor whose resistance value is $1.25 V_{IO}$ and power rating is greater than $1.25 V^2/R$ must be used. For voltage regulation applications, two resistors set the output voltage.

7.4 Device Functional Modes

7.4.1 Normal Operation

The device OUTPUT pin sources current necessary to make OUTPUT pin 1.25 V greater than ADJUST terminal to provide output regulation.

7.4.2 Operation With Low Input Voltage

The device requires up to 3-V headroom ($V_I - V_O$) to operate in regulation. With less headroom, the device may drop out and OUTPUT voltage is INPUT voltage minus drop out voltage.

7.4.3 Operation at Light Loads

The device passes its bias current to the OUTPUT pin. The load or feedback must consume this minimum current for regulation or the output may be too high. A 250- Ω feedback resistor between OUTPUT and ADJUST consumes the worst case minimum load current of 5 mA.

7.4.4 Operation in Self Protection

When an overload occurs, the device shuts down Darlington NPN output stage or reduces the output current to prevent device damage. The device automatically resets from the overload. The output may be reduced or alternate between on and off until the overload is removed.

8 Application and Implementation

NOTE

Information in the following applications sections is not part of the TI component specification, and TI does not warrant its accuracy or completeness. TI's customers are responsible for determining suitability of components for their purposes. Customers should validate and test their design implementation to confirm system functionality.

8.1 Application Information

In operation, the LM138 develops a nominal 1.25-V reference voltage (V_{REF}) between the output and adjustment terminal. The reference voltage is impressed across program resistor R_1 and, since the voltage is constant, a constant current I_1 then flows through the output set resistor R_2 , giving an output voltage calculated with Equation 1.

$$V_{OUT} = V_{REF} \left(1 + \frac{R_2}{R_1} \right) + I_{ADJ} R_2 \quad (1)$$

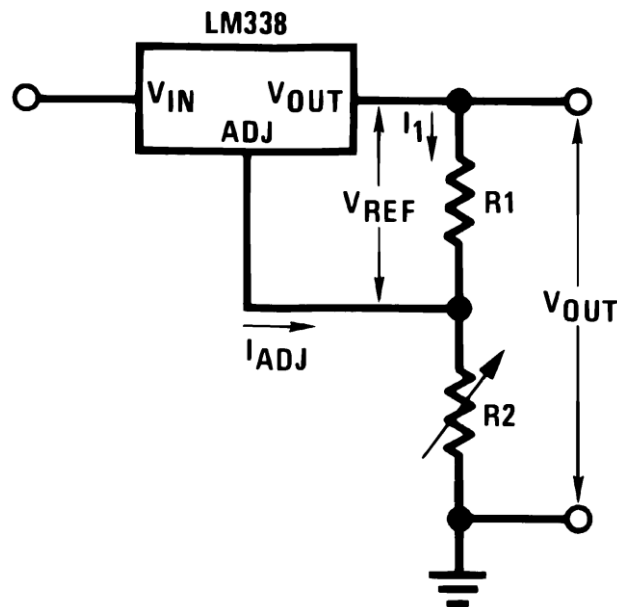

Copyright © 2016, Texas Instruments Incorporated

Figure 15. Typical Application Circuit

Because the 50- μ A current from the adjustment terminal represents an error term, the LM138 was designed to minimize I_{ADJ} and make it very constant with line and load changes. To do this, all quiescent operating current is returned to the output establishing a minimum load current requirement. If there is insufficient load on the output, the output rises.

8.2 Typical Applications

8.2.1 Constant 5-V Regulator

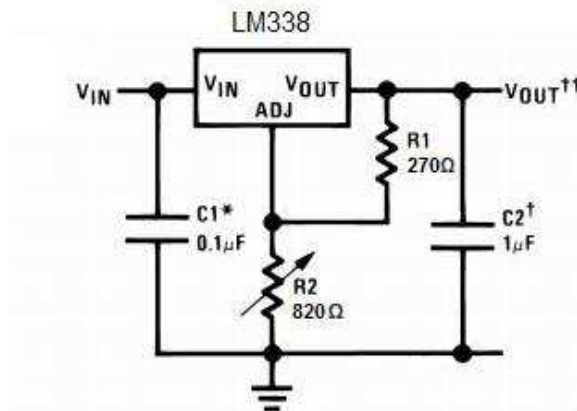

*Needed if device is more than 6 inches from filter capacitors.

†Optional—improves transient response

$$\dagger\dagger V_{OUT} = 1.25 V \left(1 + \frac{R_2}{R_1} \right) + I_{ADJ} (R_2)$$

Copyright © 2016, Texas Instruments Incorporated

Figure 16. Constant 5-V Regulator

8.2.1.1 Design Requirements

R1: Because the LM138 produces a typical 1.24 V potential between the OUTPUT and ADJUST pins, placing a 270-Ω resistor between them causes 4.6 mA to flow through R1 and R2.

R2: To achieve a 5-V output, the sum of the voltages across R1 and R2 must equal 5 V. Therefore, Vr2 must equal 3.76 V when 4.6 mA is flowing through it. $R_2 = V_{r2} / I = 3.76 V / 4.6 mA = \sim 820 \Omega$.

C_{IN}: 0.1 μF of input capacitance helps filter out unwanted noise, especially if the regulator is located far from the power supply filter capacitors.

C_{OUT}: The regulator is stable without any output capacitance, but adding a 1-μF capacitor improves the transient response.

C_{ADJ}: A 10-μF capacitor bypassing the ADJUST pin to ground improves the regulators ripple rejection.

D1: Protection diode D1 is recommended if C_{OUT} is used. The diode provides a low-impedance discharge path to prevent the capacitor from discharging into the output of the regulator (see [Protection Diodes](#)).

D2: Protection diode D2 is recommended if C_{ADJ} is used. The diode provides a low-impedance discharge path to prevent the capacitor from discharging into the output of the regulator (see [Protection Diodes](#)).

[Table 1](#) lists the design parameters for this typical application.

Table 1. Design Parameters

PARAMETER	VALUE
Feedback resistor 1 (R1)	270 Ω
Feedback resistor 2 (R2)	820 Ω
Input capacitor (C _{IN})	0.1 μ F
Output capacitor (C _{OUT})	1 μ F
Adjust capacitor (C _{ADJ})	10 μ F

8.2.1.2 Detailed Design Procedure

8.2.1.2.1 External Capacitors

An input bypass capacitor is recommended. A 0.1- μ F disc or 1- μ F solid tantalum on the input is suitable input bypassing for almost all applications. The device is more sensitive to the absence of input bypassing when adjustment or output capacitors are used but the above values eliminate the possibility of problems.

The adjustment terminal can be bypassed to ground on the LM138 to improve ripple rejection. This bypass capacitor prevents ripple from being amplified as the output voltage is increased. With a 10- μ F bypass capacitor, 75-dB ripple rejection is obtainable at any output level. Increases over 20 μ F do not appreciably improve the ripple rejection at frequencies above 120 Hz. If the bypass capacitor is used, it is sometimes necessary to include protection diodes to prevent the capacitor from discharging through internal low current paths and damaging the device.

In general, the best type of capacitors to use are solid tantalum. Solid tantalum capacitors have low impedance even at high frequencies. Depending upon capacitor construction, it takes about 25 μ F in aluminum electrolytic to equal 1- μ F solid tantalum at high frequencies. Ceramic capacitors are also good at high frequencies; but some types have a large decrease in capacitance at frequencies around 0.5 MHz. For this reason, 0.01- μ F disc may seem to work better than a 0.1- μ F disc as a bypass.

Although the LM138 is stable with no output capacitors, like any feedback circuit, certain values of external capacitance can cause excessive ringing. This occurs with values between 500 pF and 5000 pF. A 1- μ F solid tantalum (or 25- μ F aluminum electrolytic) on the output swamps this effect and insures stability.

8.2.1.2.2 Load Regulation

The LM138 is capable of providing extremely good load regulation but a few precautions are needed to obtain maximum performance. The current set resistor connected between the adjustment terminal and the output terminal (usually 240 Ω) must be tied directly to the output of the regulator (case) rather than near the load. This eliminates line drops from appearing effectively in series with the reference and degrading regulation. For example, a 15-V regulator with 0.05- Ω resistance between the regulator and load has a load regulation due to line resistance of $0.05 \Omega \times I_L$. If the set resistor is connected near the load, the effective line resistance is 0.05 Ω (1 + R2/R1) or in this case, 11.5 times worse.

[Figure 17](#) shows the effect of resistance between the regulator and 240- Ω set resistor.

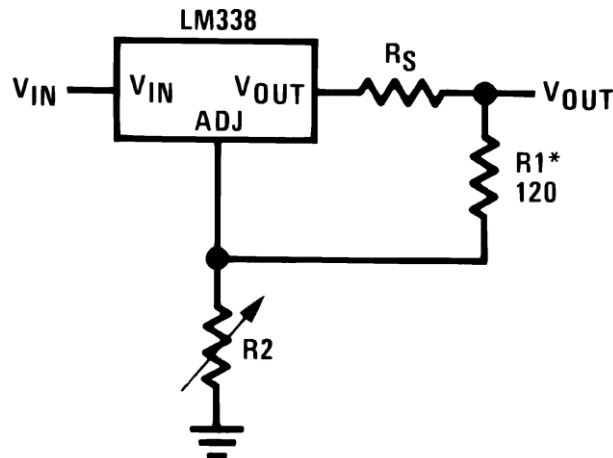

Copyright © 2016, Texas Instruments Incorporated

Figure 17. Regulator With Line Resistance in Output Lead

With the TO-3 package, it is easy to minimize the resistance from the case to the set resistor, by using 2 separate leads to the case. The ground of R2 can be returned near the ground of the load to provide remote ground sensing and improve load regulation.

8.2.1.2.3 Protection Diodes

When external capacitors are used with *any* IC regulator it is sometimes necessary to add protection diodes to prevent the capacitors from discharging through low current points into the regulator. Most 20- μ F capacitors have low enough internal series resistance to deliver 20-A spikes when shorted. Although the surge is short, there is enough energy to damage parts of the IC.

When an output capacitor is connected to a regulator and the input is shorted, the output capacitor discharges into the output of the regulator. The discharge current depends on the value of the capacitor, the output voltage of the regulator, and the rate of decrease of V_{IN} . In the LM138 this discharge path is through a large junction that is able to sustain 25-A surge with no problem. This is not true of other types of positive regulators. For output capacitors of 100 μ F or less at output of 15 V or less, there is no need to use diodes.

The bypass capacitor on the adjustment terminal can discharge through a low current junction. Discharge occurs when *either* the input or output is shorted. Internal to the LM138 is a 50- Ω resistor which limits the peak discharge current. No protection is needed for output voltages of 25-V or less and 10- μ F capacitance. [Figure 18](#) shows an LM138 with protection diodes included for use with outputs greater than 25 V and high values of output capacitance.

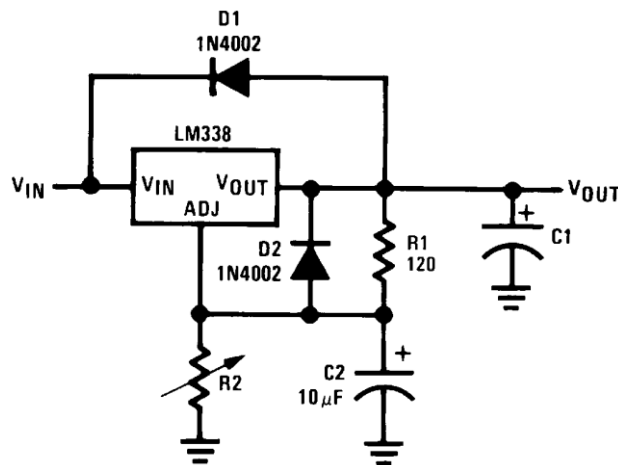

Copyright © 2016, Texas Instruments Incorporated

$$V_{OUT} = 1.25V \left(1 + \frac{R2}{R1} \right) + I_{ADJ}R2$$

D1 protects against C1
D2 protects against C2

Figure 18. Regulator With Protection Diodes

8.2.1.3 Application Curves

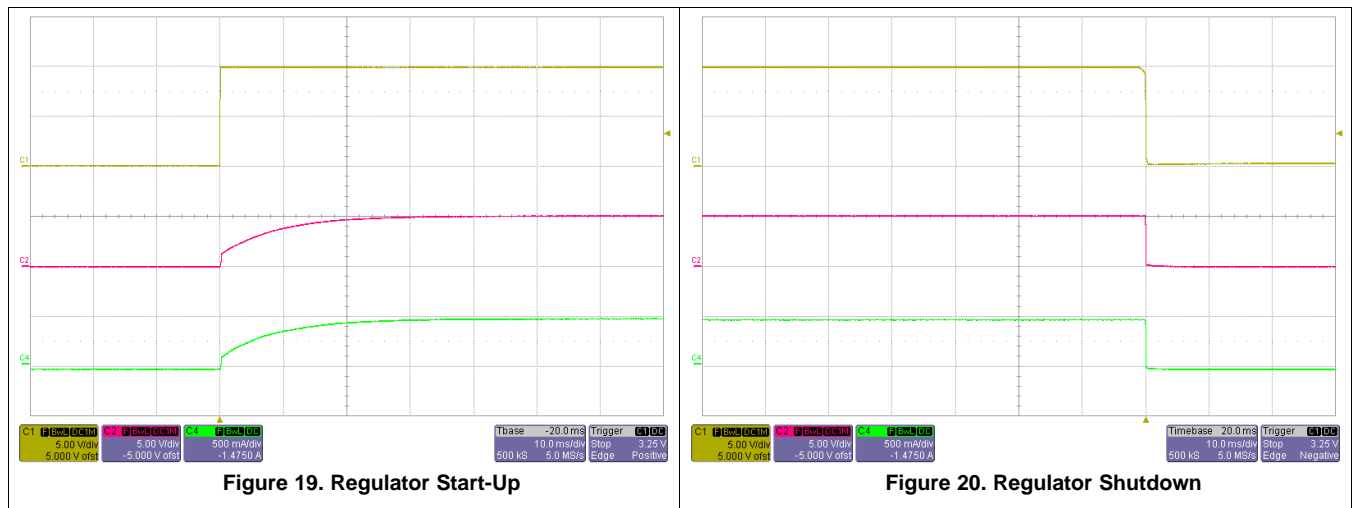

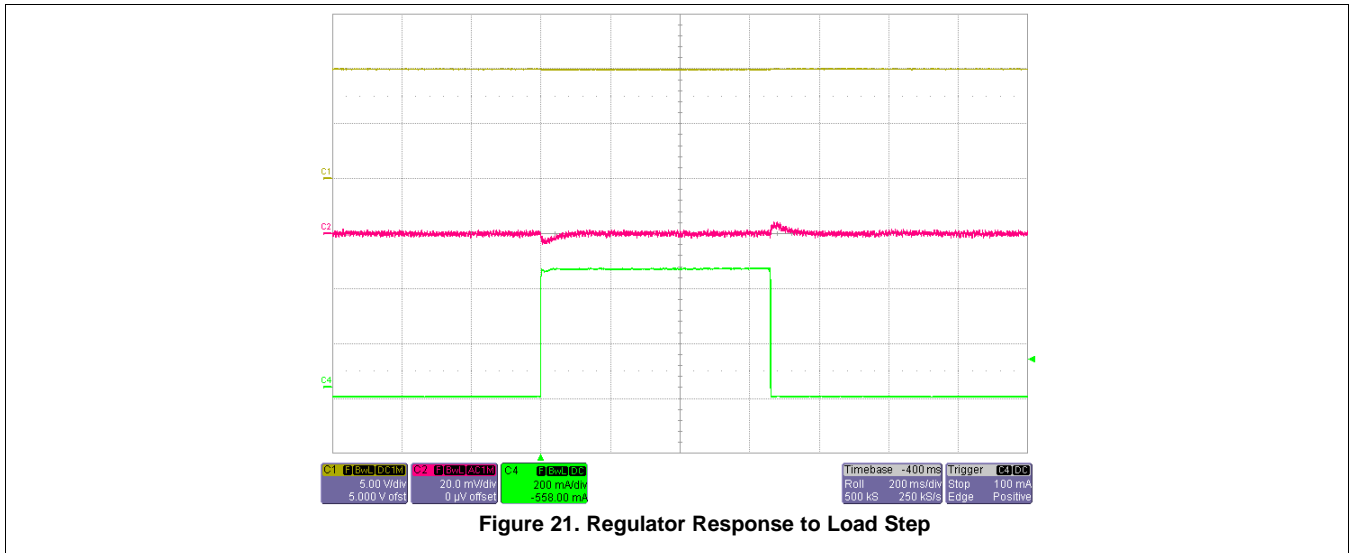

8.3 System Examples

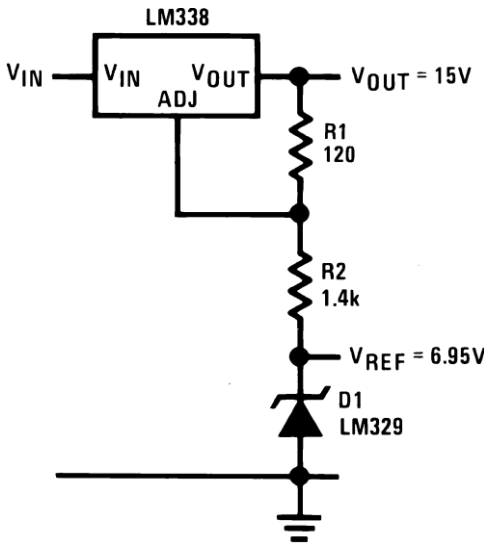

Copyright © 2016, Texas Instruments Incorporated

Figure 22. Regulator and Voltage Reference

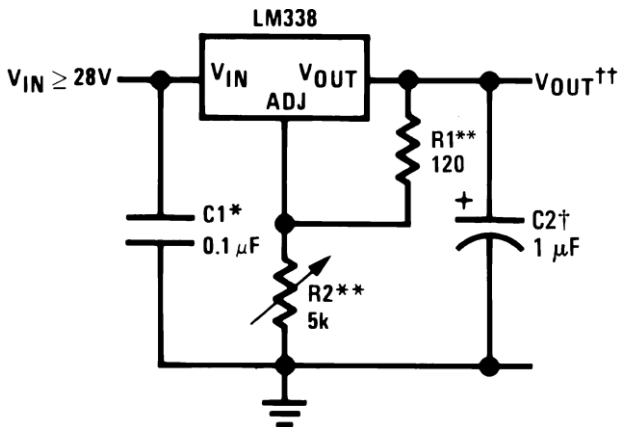

Copyright © 2016, Texas Instruments Incorporated

Figure 23. 1.2-V to 25-V Adjustable Regulator

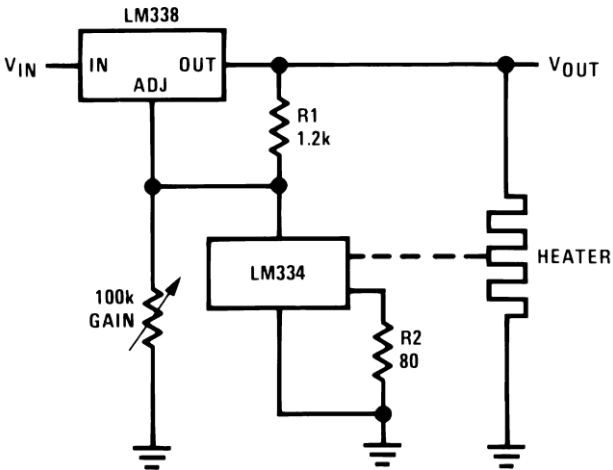

Copyright © 2016, Texas Instruments Incorporated

Figure 24. Temperature Controller

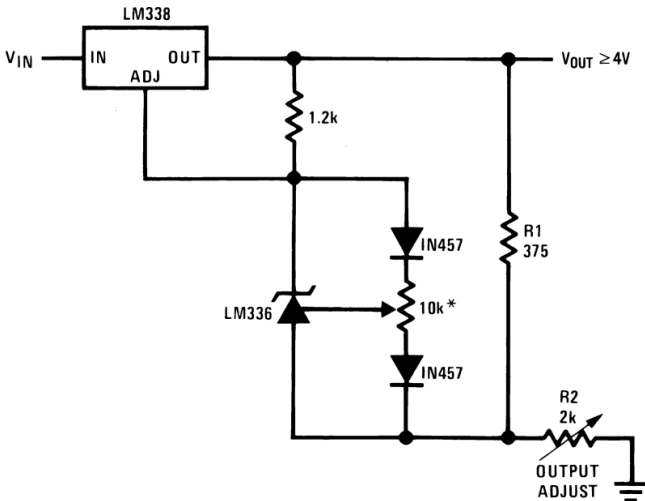

Copyright © 2016, Texas Instruments Incorporated

Figure 25. Precision Power Regulator With Low Temperature Coefficient

Full output current not available at high input-output voltages
 †Optional—improves transient response. Output capacitors in the range of 1 μF to 1000 μF of aluminum or tantalum electrolytic are commonly used to provide improved output impedance and rejection of transients.

*Needed if device is more than 6 inches from filter capacitors.

$$\dagger\dagger V_{OUT} = 1.25V \left(1 + \frac{R2}{R1} \right) + I_{ADJ} (R2)$$

**R1 = 240 Ω for LM138. R1, R2 as an assembly can be ordered from Bourns:

MIL part no. 7105A-AT2-502

COMM part no. 7105A-AT7-502

* Adjust for 3.75 across R1

System Examples (continued)

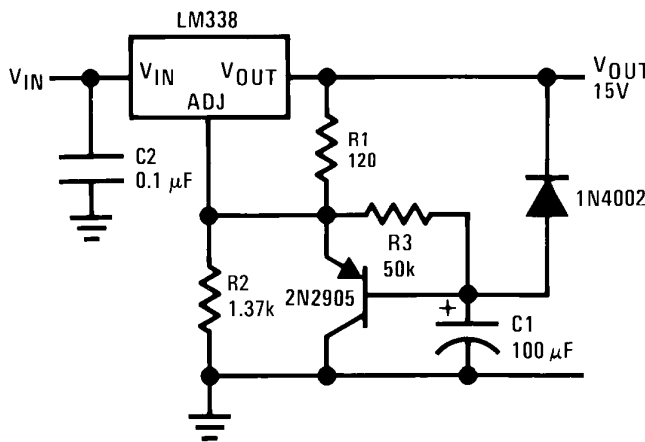

Copyright © 2016, Texas Instruments Incorporated

Figure 26. Slow Turnon 15-V Regulator

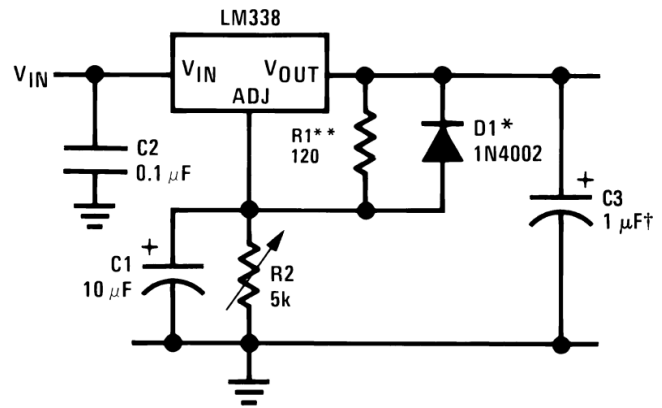

Copyright © 2016, Texas Instruments Incorporated

†Solid tantalum
 *Discharges C1 if output is shorted to ground
 **R1 = 240 Ω for LM138

Figure 27. Adjustable Regulator With Improved Ripple Rejection

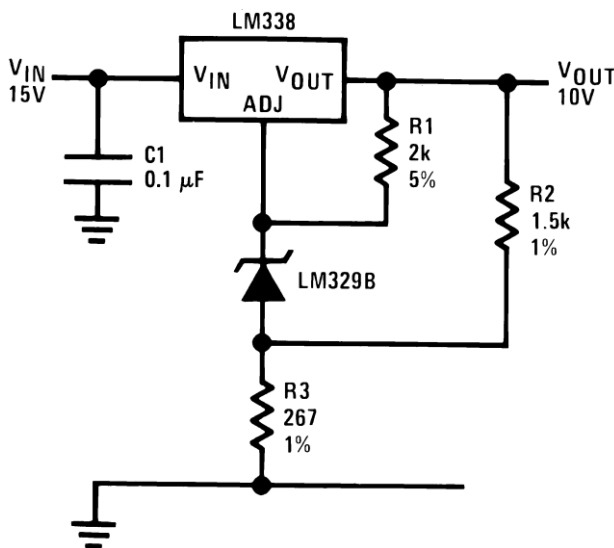

Copyright © 2016, Texas Instruments Incorporated

Figure 28. High Stability 10-V Regulator

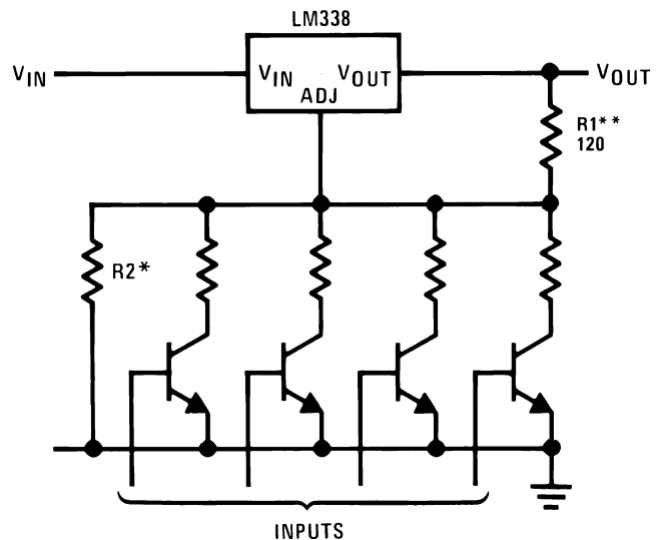

Copyright © 2016, Texas Instruments Incorporated

*Sets maximum V_{OUT}
 **R1 = 240 Ω for LM138

Figure 29. Digitally Selected Outputs

System Examples (continued)

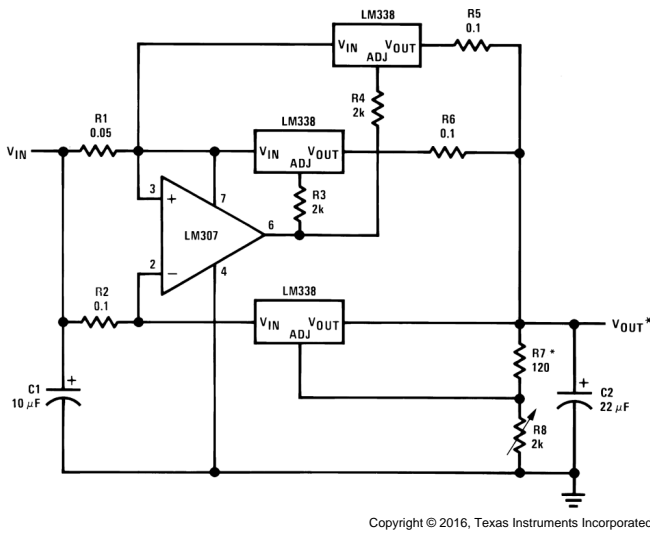

Copyright © 2016, Texas Instruments Incorporated

* Minimum load—100 mA

Figure 30. 15-A Regulator

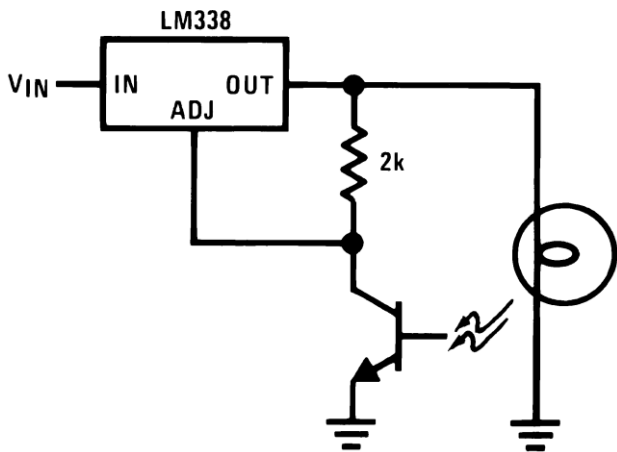

Copyright © 2016, Texas Instruments Incorporated

Figure 32. Light Controller

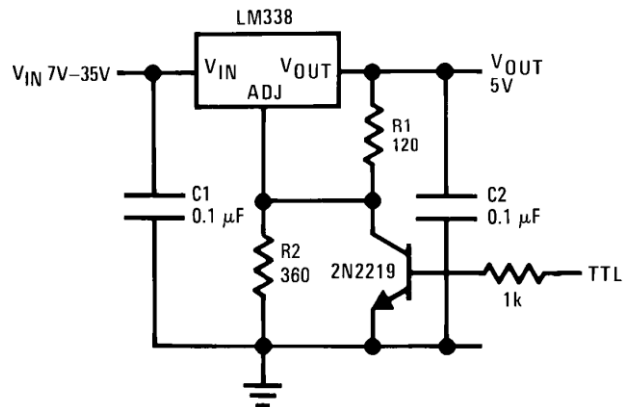

Copyright © 2016, Texas Instruments Incorporated

** Minimum output ≈ 1.2 V

Figure 31. 5-V Logic Regulator With Electronic Shutdown**

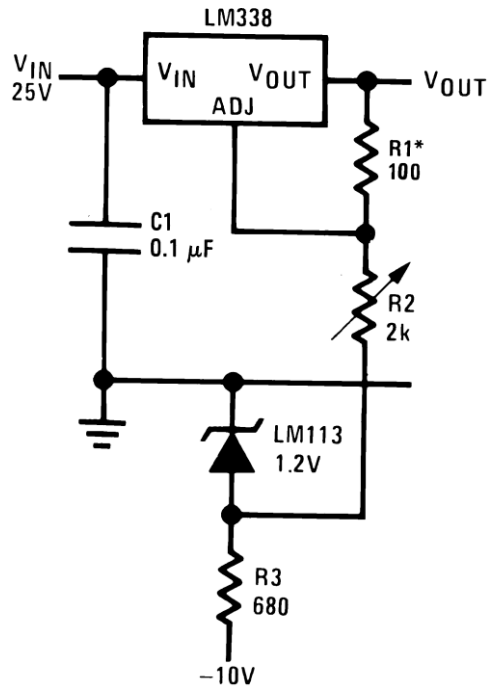

Copyright © 2016, Texas Instruments Incorporated

* R1 = 240 Ω, R2 = 5k for LM138
Full output current not available at high input-output voltages

Figure 33. 0 to 22-V Regulator

System Examples (continued)

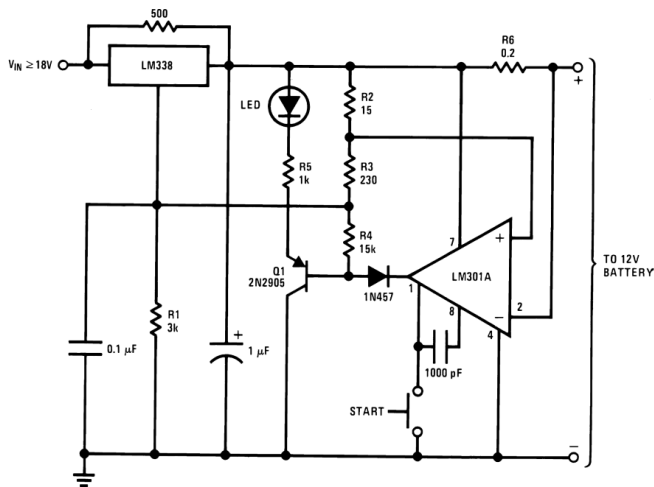

Copyright © 2016, Texas Instruments Incorporated

Figure 34. 12-V Battery Charger

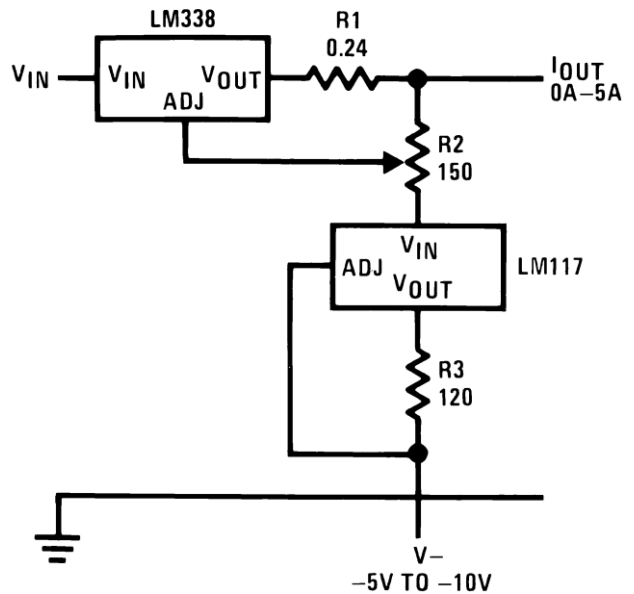

Copyright © 2016, Texas Instruments Incorporated

Figure 35. Adjustable Current Regulator

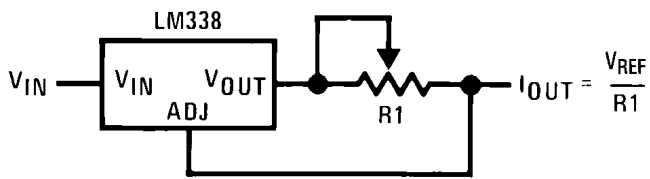

Copyright © 2016, Texas Instruments Incorporated

Figure 36. Precision Current Limiter

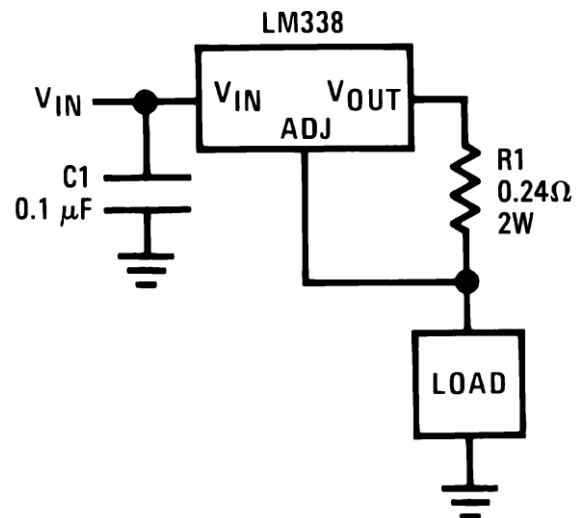

Copyright © 2016, Texas Instruments Incorporated

Figure 37. 5-A Current Regulator

System Examples (continued)

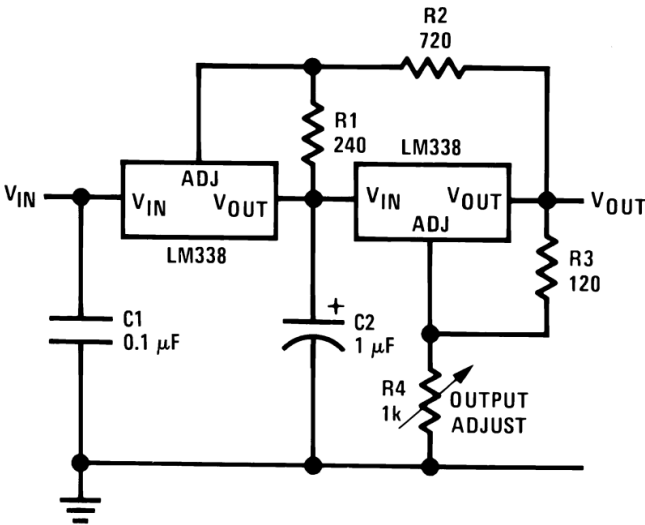

Copyright © 2016, Texas Instruments Incorporated

Figure 38. Tracking Preregulator

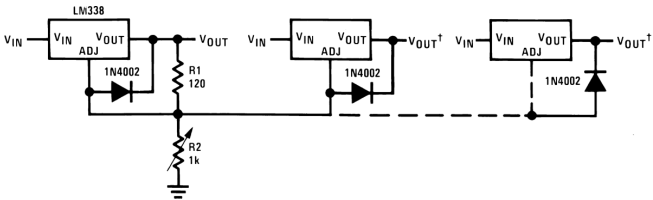

Copyright © 2016, Texas Instruments Incorporated

† Minimum load—10 mA
* All outputs within ±100 mV

Figure 39. Adjusting Multiple On-Card Regulators With Single Control*

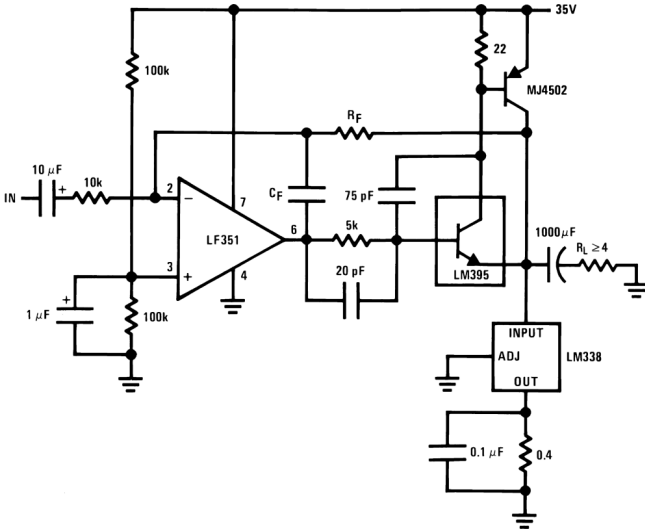

Copyright © 2016, Texas Instruments Incorporated

$A_V = 1$, $R_F = 10k$, $C_F = 100$ pF
 $A_V = 10$, $R_F = 100k$, $C_F = 10$ pF
Bandwidth ≥ 100 kHz
Distortion $\leq 0.1\%$

Figure 40. Power Amplifier

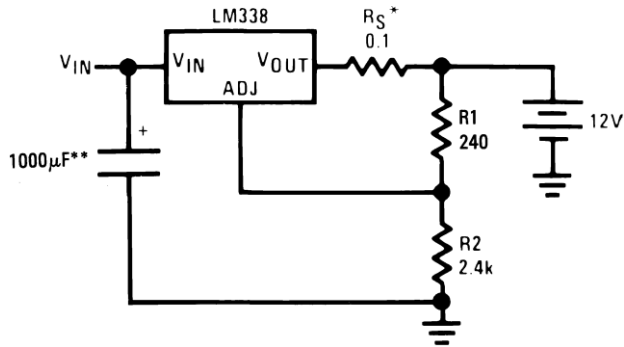

Copyright © 2016, Texas Instruments Incorporated

* R_S —sets output impedance of charger $Z_{OUT} = R_S \left(1 + \frac{R_2}{R_1} \right)$

Use of R_S allows low charging rates with fully charged battery.
**The 1000 μ F is recommended to filter out input transients

* R_S —sets output impedance of charger $Z_{OUT} = R_S \left(1 + \frac{R_2}{R_1} \right)$

Use of R_S allows low charging rates with fully charged battery.
**The 1000 μ F is recommended to filter out input transients

Figure 41. Simple 12-V Battery Charger

System Examples (continued)

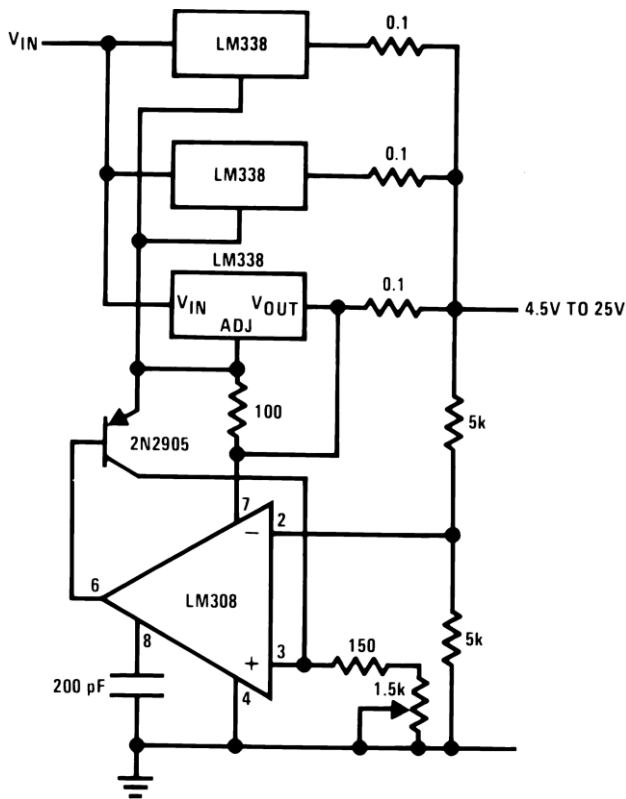

Copyright © 2016, Texas Instruments Incorporated

Figure 42. Adjustable 15-A Regulator

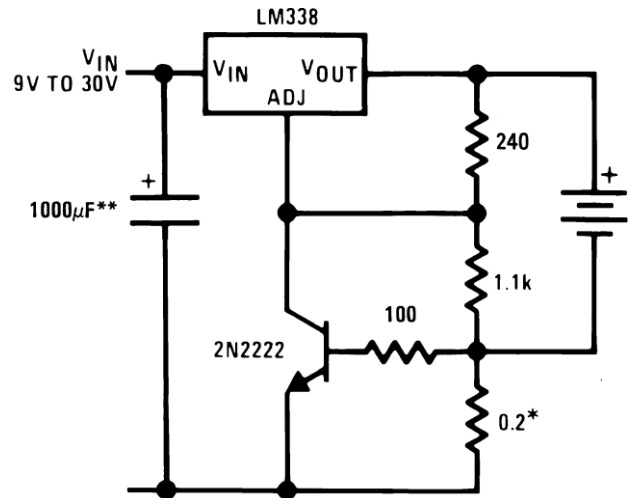

Copyright © 2016, Texas Instruments Incorporated

* Set max charge current to 3 A

** THE 1000 μ F is recommended to filter out input transients.

Figure 43. Current Limited 6-V Charger

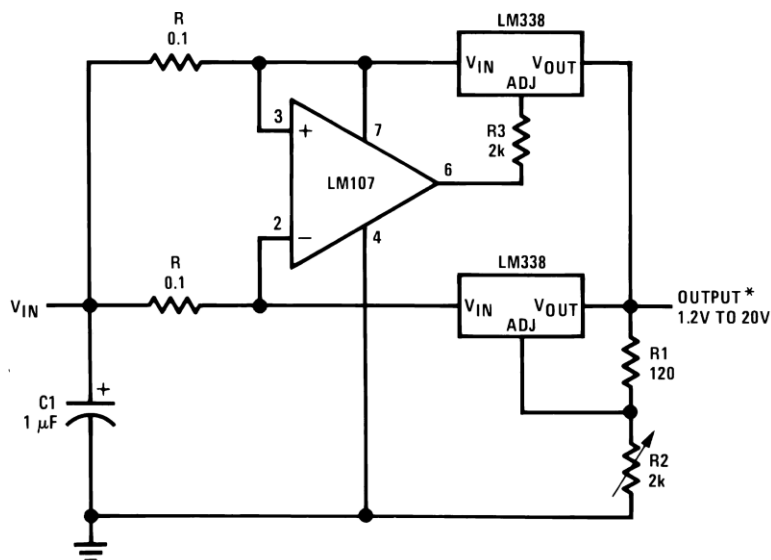

Copyright © 2016, Texas Instruments Incorporated

* Minimum load—100 mA

Figure 44. 10-A Regulator

9 Power Supply Recommendations

The input supply to LM138 and LM338 must be kept at a voltage level such that its maximum input to output differential voltage rating is not exceeded. The minimum dropout voltage must also be met with extra headroom when possible to keep the LM138 and LM338 in regulation. TI recommends a capacitor be placed at the input to bypass noise.

10 Layout

10.1 Layout Guidelines

Some layout guidelines must be followed to ensure proper regulation of the output voltage with minimum noise. Traces carrying the load current must be wide to reduce the amount of parasitic trace inductance and the feedback loop from V_{OUT} to ADJ must be kept as short as possible. To improve PSRR, a bypass capacitor can be placed at the ADJ pin and must be placed as close as possible to the IC. In cases when V_{IN} shorts to ground, an external diode must be placed from V_{OUT} to V_{IN} to divert the surge current from the output capacitor and protect the IC. Similarly, in cases when a large bypass capacitor is placed at the ADJ pin and V_{OUT} shorts to ground, an external diode must be placed from ADJ to V_{OUT} to provide a path for the bypass capacitor to discharge. These diodes must be placed close to the corresponding IC pins to increase their effectiveness.

10.2 Layout Example

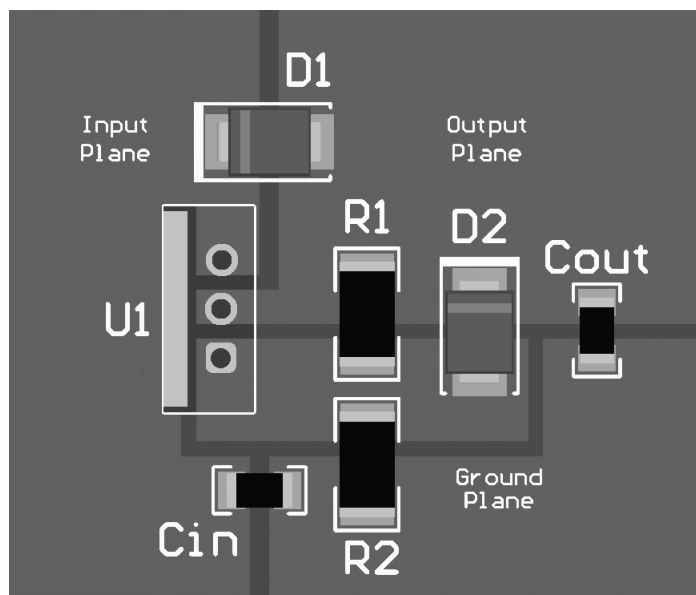

Figure 45. LMx38 Layout

11 Device and Documentation Support

11.1 Receiving Notification of Documentation Updates

To receive notification of documentation updates, navigate to the device product folder on ti.com. In the upper right corner, click on *Alert me* to register and receive a weekly digest of any product information that has changed. For change details, review the revision history included in any revised document.

11.2 Related Links

The table below lists quick access links. Categories include technical documents, support and community resources, tools and software, and quick access to sample or buy.

Table 2. Related Links

PARTS	PRODUCT FOLDER	SAMPLE & BUY	TECHNICAL DOCUMENTS	TOOLS & SOFTWARE	SUPPORT & COMMUNITY
LM138	Click here	Click here	Click here	Click here	Click here
LM338	Click here	Click here	Click here	Click here	Click here

11.3 Community Resources

The following links connect to TI community resources. Linked contents are provided "AS IS" by the respective contributors. They do not constitute TI specifications and do not necessarily reflect TI's views; see TI's [Terms of Use](#).

TI E2E™ Online Community *TI's Engineer-to-Engineer (E2E) Community*. Created to foster collaboration among engineers. At e2e.ti.com, you can ask questions, share knowledge, explore ideas and help solve problems with fellow engineers.

Design Support *TI's Design Support* Quickly find helpful E2E forums along with design support tools and contact information for technical support.

11.4 Trademarks

E2E is a trademark of Texas Instruments.
All other trademarks are the property of their respective owners.

11.5 Electrostatic Discharge Caution



This integrated circuit can be damaged by ESD. Texas Instruments recommends that all integrated circuits be handled with appropriate precautions. Failure to observe proper handling and installation procedures can cause damage.

ESD damage can range from subtle performance degradation to complete device failure. Precision integrated circuits may be more susceptible to damage because very small parametric changes could cause the device not to meet its published specifications.

11.6 Glossary



[SLYZ022](#) — *TI Glossary*.

This glossary lists and explains terms, acronyms, and definitions.

12 Mechanical, Packaging, and Orderable Information

The following pages include mechanical, packaging, and orderable information. This information is the most current data available for the designated devices. This data is subject to change without notice and revision of this document. For browser-based versions of this data sheet, refer to the left-hand navigation.

PACKAGING INFORMATION

Orderable Device	Status (1)	Package Type	Package Drawing	Pins	Package Qty	Eco Plan (2)	Lead finish/ Ball material (6)	MSL Peak Temp (3)	Op Temp (°C)	Device Marking (4/5)	Samples
LM138K STEEL	ACTIVE	TO-3	NDS	2	50	Non-RoHS & Non-Green	Call TI	Call TI	-55 to 125	LM138K STEELP+	
LM138K STEEL/NOPB	ACTIVE	TO-3	NDS	2	50	RoHS & Green	Call TI	Level-1-NA-UNLIM	-55 to 125	LM138K STEELP+	
LM338T	NRND	TO-220	NDE	3	45	Non-RoHS & Green	Call TI	Level-1-NA-UNLIM	0 to 125	LM338T P+	
LM338T/NOPB	ACTIVE	TO-220	NDE	3	45	RoHS & Green	SN	Level-1-NA-UNLIM	0 to 125	LM338T P+	

(1) The marketing status values are defined as follows:

ACTIVE: Product device recommended for new designs.

LIFEBUY: TI has announced that the device will be discontinued, and a lifetime-buy period is in effect.

NRND: Not recommended for new designs. Device is in production to support existing customers, but TI does not recommend using this part in a new design.

PREVIEW: Device has been announced but is not in production. Samples may or may not be available.

OBSOLETE: TI has discontinued the production of the device.

(2) **RoHS:** TI defines "RoHS" to mean semiconductor products that are compliant with the current EU RoHS requirements for all 10 RoHS substances, including the requirement that RoHS substance do not exceed 0.1% by weight in homogeneous materials. Where designed to be soldered at high temperatures, "RoHS" products are suitable for use in specified lead-free processes. TI may reference these types of products as "Pb-Free".

RoHS Exempt: TI defines "RoHS Exempt" to mean products that contain lead but are compliant with EU RoHS pursuant to a specific EU RoHS exemption.

Green: TI defines "Green" to mean the content of Chlorine (Cl) and Bromine (Br) based flame retardants meet JS709B low halogen requirements of <=1000ppm threshold. Antimony trioxide based flame retardants must also meet the <=1000ppm threshold requirement.

(3) MSL, Peak Temp. - The Moisture Sensitivity Level rating according to the JEDEC industry standard classifications, and peak solder temperature.

(4) There may be additional marking, which relates to the logo, the lot trace code information, or the environmental category on the device.

(5) Multiple Device Markings will be inside parentheses. Only one Device Marking contained in parentheses and separated by a "-" will appear on a device. If a line is indented then it is a continuation of the previous line and the two combined represent the entire Device Marking for that device.

(6) Lead finish/Ball material - Orderable Devices may have multiple material finish options. Finish options are separated by a vertical ruled line. Lead finish/Ball material values may wrap to two lines if the finish value exceeds the maximum column width.

Important Information and Disclaimer:The information provided on this page represents TI's knowledge and belief as of the date that it is provided. TI bases its knowledge and belief on information provided by third parties, and makes no representation or warranty as to the accuracy of such information. Efforts are underway to better integrate information from third parties. TI has taken and

continues to take reasonable steps to provide representative and accurate information but may not have conducted destructive testing or chemical analysis on incoming materials and chemicals. TI and TI suppliers consider certain information to be proprietary, and thus CAS numbers and other limited information may not be available for release.

In no event shall TI's liability arising out of such information exceed the total purchase price of the TI part(s) at issue in this document sold by TI to Customer on an annual basis.

TUBE

*All dimensions are nominal

Device	Package Name	Package Type	Pins	SPQ	L (mm)	W (mm)	T (μm)	B (mm)
LM338T	NDE	TO-220	3	45	502	33	6985	4.06
LM338T	NDE	TO-220	3	45	502	33	6985	4.06
LM338T/NOPB	NDE	TO-220	3	45	502	33	6985	4.06

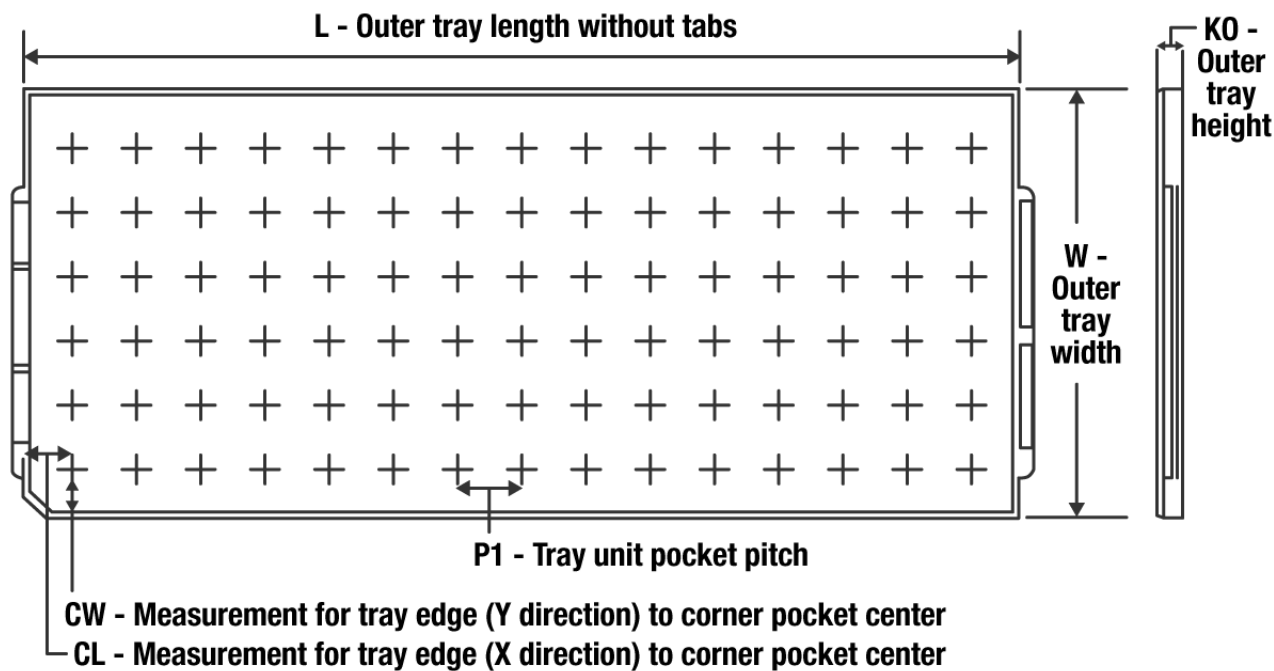
TRAY

Chamfer on Tray corner indicates Pin 1 orientation of packed units.

*All dimensions are nominal

Device	Package Name	Package Type	Pins	SPQ	Unit array matrix	Max temperature (°C)	L (mm)	W (mm)	K0 (µm)	P1 (mm)	CL (mm)	CW (mm)
LM138K STEEL	NDS	TO-CAN	2	50	9 X 6	NA	292.1	215.9	25654	3.87	22.3	25.4
LM138K STEEL/NOPB	NDS	TO-CAN	2	50	9 X 6	NA	292.1	215.9	25654	3.87	22.3	25.4

NDE0003B



NDS0002A

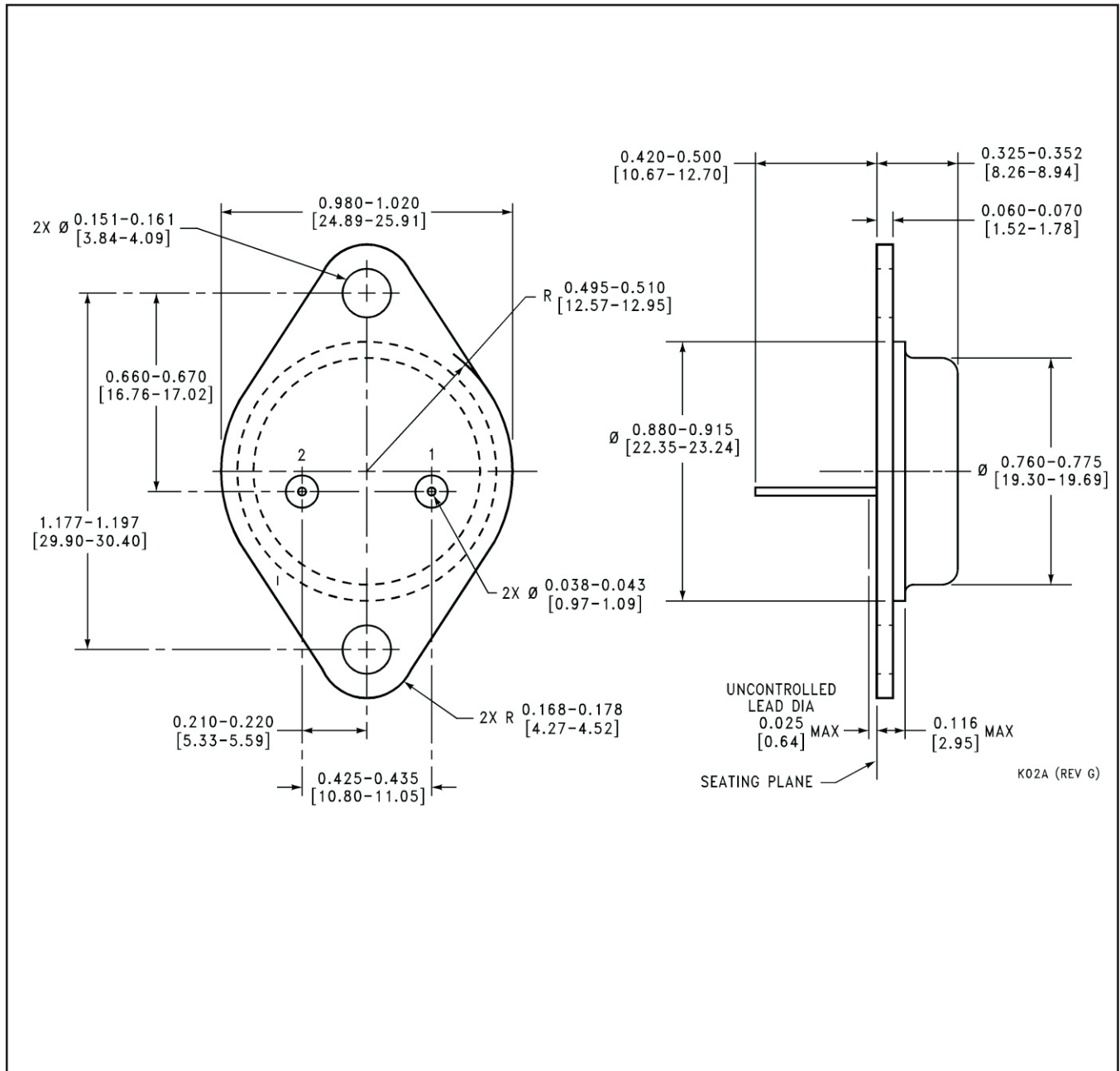

IMPORTANT NOTICE AND DISCLAIMER

TI PROVIDES TECHNICAL AND RELIABILITY DATA (INCLUDING DATA SHEETS), DESIGN RESOURCES (INCLUDING REFERENCE DESIGNS), APPLICATION OR OTHER DESIGN ADVICE, WEB TOOLS, SAFETY INFORMATION, AND OTHER RESOURCES "AS IS" AND WITH ALL FAULTS, AND DISCLAIMS ALL WARRANTIES, EXPRESS AND IMPLIED, INCLUDING WITHOUT LIMITATION ANY IMPLIED WARRANTIES OF MERCHANTABILITY, FITNESS FOR A PARTICULAR PURPOSE OR NON-INFRINGEMENT OF THIRD PARTY INTELLECTUAL PROPERTY RIGHTS.

These resources are intended for skilled developers designing with TI products. You are solely responsible for (1) selecting the appropriate TI products for your application, (2) designing, validating and testing your application, and (3) ensuring your application meets applicable standards, and any other safety, security, regulatory or other requirements.

These resources are subject to change without notice. TI grants you permission to use these resources only for development of an application that uses the TI products described in the resource. Other reproduction and display of these resources is prohibited. No license is granted to any other TI intellectual property right or to any third party intellectual property right. TI disclaims responsibility for, and you will fully indemnify TI and its representatives against, any claims, damages, costs, losses, and liabilities arising out of your use of these resources.

TI's products are provided subject to [TI's Terms of Sale](#) or other applicable terms available either on ti.com or provided in conjunction with such TI products. TI's provision of these resources does not expand or otherwise alter TI's applicable warranties or warranty disclaimers for TI products.

TI objects to and rejects any additional or different terms you may have proposed.

Mailing Address: Texas Instruments, Post Office Box 655303, Dallas, Texas 75265
Copyright © 2022, Texas Instruments Incorporated