

**TDA7050**  
Low voltage mono/stereo power  
amplifier

Product specification  
File under Integrated Circuits, IC01

June 1989

**Philips**  
Semiconductors



**PHILIPS**

**Low voltage mono/stereo power amplifier****TDA7050****GENERAL DESCRIPTION**

The TDA7050 is a low voltage audio amplifier for small radios with headphones (such as watch, pen and pocket radios) in mono (bridge-tied load) or stereo applications.

**Features**

- Limited to battery supply application only (typ. 3 and 4 V)
- Operates with supply voltage down to 1,6 V
- No external components required
- Very low quiescent current
- Fixed integrated gain of 26 dB, floating differential input
- Flexibility in use – mono BTL as well as stereo
- Small dimension of encapsulation (see package design example)

**QUICK REFERENCE DATA**

Supply voltage range	$V_F$		1,6 to 6,0 V
Total quiescent current (at $V_F = 3$ V)	$I_{tot}$	typ.	3,2 mA
<b>Bridge tied load application (BTL)</b>			
Output power at $R_L = 32 \Omega$ $V_F = 3$ V; $d_{tot} = 10\%$	$P_o$	typ.	140 mW
D.C. output offset voltage between the outputs	$ \Delta V $	max.	70 mV
Noise output voltage (r.m.s. value) at $f = 1$ kHz; $R_S = 5$ k $\Omega$	$V_{no(rms)}$	typ.	140 $\mu$ V
<b>Stereo application</b>			
Output power at $R_L = 32 \Omega$ $d_{tot} = 10\%$ ; $V_F = 3$ V	$P_o$	typ.	35 mW
$d_{tot} = 10\%$ ; $V_F = 4,5$ V	$P_o$	typ.	75 mW
Channel separation at $R_S = 0 \Omega$ ; $f = 1$ kHz	$\alpha$	typ.	40 dB
Noise output voltage (r.m.s. value) at $f = 1$ kHz; $R_S = 5$ k $\Omega$	$V_{no(rms)}$	typ.	100 $\mu$ V

**PACKAGE OUTLINE**

8-lead DIL; plastic (SOT97); SOT97-1; 1996 July 23.

## Low voltage mono/stereo power amplifier

TDA7050

**RATINGS**

Limiting values in accordance with the Absolute Maximum System (IEC 134)

Supply voltage	$V_P$	max.	6 V
Peak output current	$I_{OM}$	max.	150 mA
Total power dissipation	see derating curve Fig.1		
Storage temperature range	$T_{stg}$	-55 to +150 °C	
Crystal temperature	$T_C$	max.	100 °C
A.C. and d.c. short-circuit duration at $V_P = 3,0$ V (during mishandling)	$t_{sc}$	max.	5 s

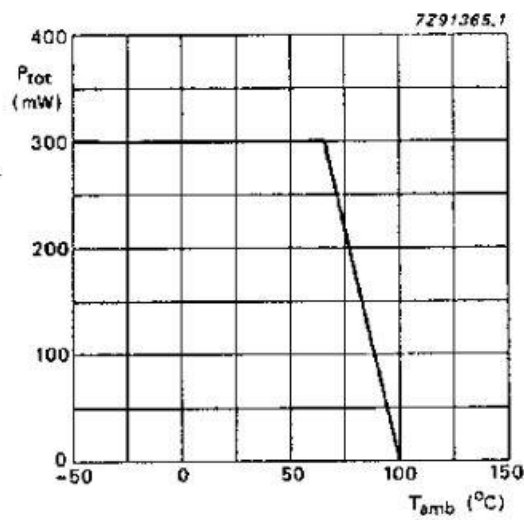

Fig.1 Power derating curve.

**THERMAL RESISTANCE**

From junction to ambient

 $R_{thj-a} = 110$  K/W

## Low voltage mono/stereo power amplifier

TDA7050

## CHARACTERISTICS

 $V_D = 3\text{ V}$ ;  $f = 1\text{ kHz}$ ;  $R_L = 32\ \Omega$ ;  $T_{amb} = 25\text{ }^\circ\text{C}$ ; unless otherwise specified

PARAMETER	SYMBOL	MIN.	TYP.	MAX.	UNIT
<b>Supply</b>					
Supply voltage	$V_D$	1,6	—	6,0	V
Total quiescent current	$I_{tot}$	—	3,2	4	mA
Bridge-tied load application (BTL); see Fig.4					
Output power; note 1					
$V_D = 3,0\text{ V}$ ; $d_{tot} = 10\%$	$P_o$	—	140	—	mW
$V_D = 4,5\text{ V}$ ; $d_{tot} = 10\%$ ( $R_L = 64\ \Omega$ ) $P_o$		—	150	—	mW
Voltage gain	$G_v$	—	32	—	dB
Noise output voltage (r.m.s. value)					
$R_s = 5\text{ k}\Omega$ ; $f = 1\text{ kHz}$	$V_{no(ms)}$	—	140	$-\mu\text{ V}$	
$R_s = 0\ \Omega$ ; $f = 500\text{ kHz}$ ; $B = 5\text{ kHz}$	$V_{no(ms)}$	—	tbef	$-\mu\text{ V}$	
D.C. output offset voltage (at $R_s = 5\text{ k}\Omega$ ) $\Delta V$					
		—	—	70	mV
Input impedance (at $R_s = \infty$ ) $Z_i 1$					
		—	—	—	$M\Omega$
Input bias current					
	$I_i$	—	40	—	nA
Stereo application; see Fig.5					
Output power; note 1					
$V_D = 3,0\text{ V}$ ; $d_{tot} = 10\%$	$P_o$	—	35	—	mW
$V_D = 4,5\text{ V}$ ; $d_{tot} = 10\%$	$P_o$	—	75	—	mW
Voltage gain	$G_v$	24,5	26	27,5	dB
Noise output voltage (r.m.s. value)					
$R_s = 5\text{ k}\Omega$ ; $f = 1\text{ kHz}$	$V_{no(ms)}$	—	100	$-\mu\text{ V}$	
$R_s = 0\ \Omega$ ; $f = 500\text{ kHz}$ ; $B = 5\text{ kHz}$	$V_{no(ms)}$	—	tbef	$-\mu\text{ V}$	
Channel separation					
$R_s = 0\ \Omega$ ; $f = 1\text{ kHz}$	$\alpha$	30	40	—	dB
Input impedance (at $R_s = \infty$ ) $Z_i 2$					
		—	—	—	$M\Omega$
Input bias current					
	$I_i$	—	20	—	nA

## Note

- Output power is measured directly at the output pins of the IC. It is shown as a function of the supply voltage in Fig.2 (BTL application) and Fig.3 (stereo application).

Low voltage mono/stereo power amplifier

TDA7050

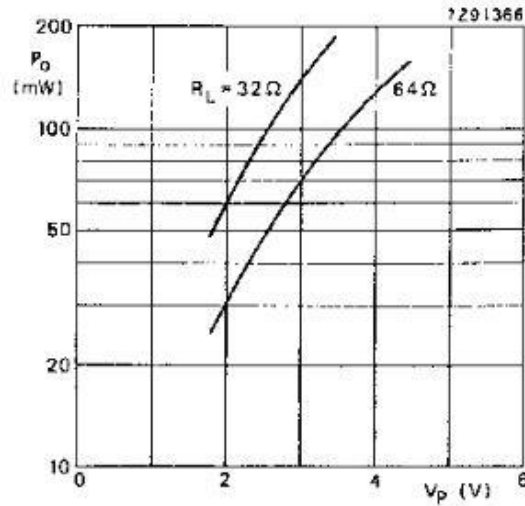

Fig. 2 Output power across the load impedance ( $R_L$ ) as a function of supply voltage ( $V_p$ ) in BTL application. Measurements were made at  $f = 1$  kHz;  $d_{int} = 10\%$ ;  $T_{amb} = 25$  °C.

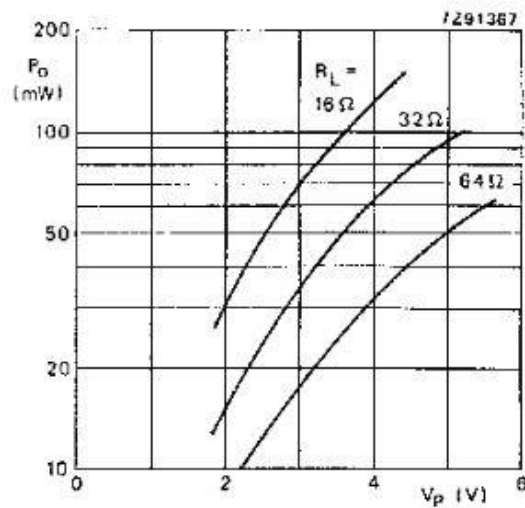

Fig. 3 Output power across the load impedance ( $R_L$ ) as a function of supply voltage ( $V_p$ ) in stereo application. Measurements were made at  $f = 1$  kHz;  $d_{int} = 10\%$ ;  $T_{amb} = 25$  °C.

Low voltage mono/stereo power amplifier

TDA7050

APPLICATION INFORMATION

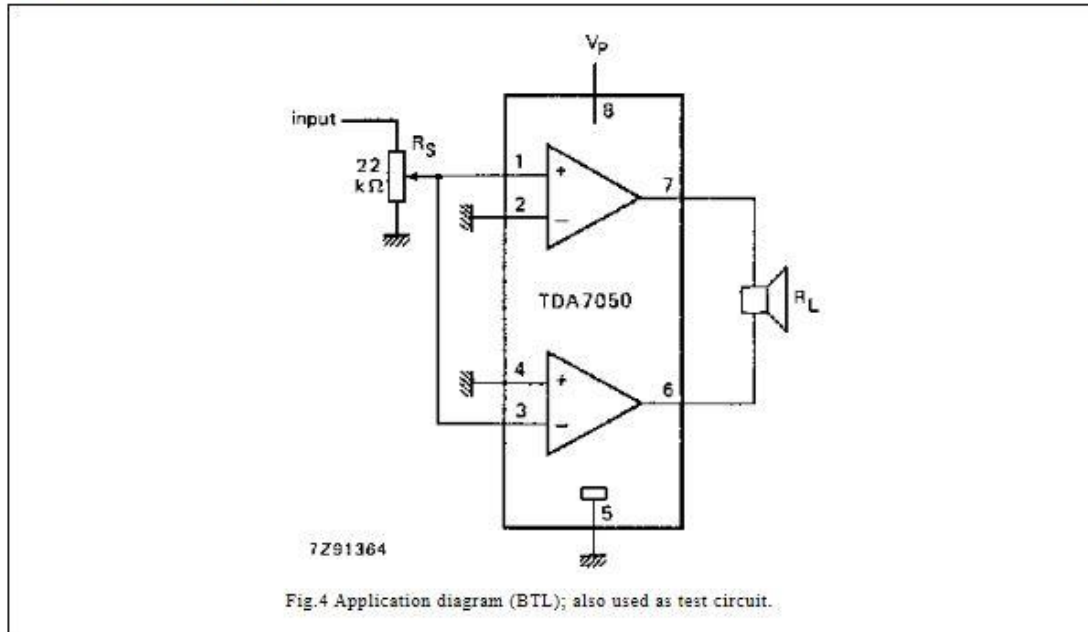

Fig.4 Application diagram (BTL); also used as test circuit.

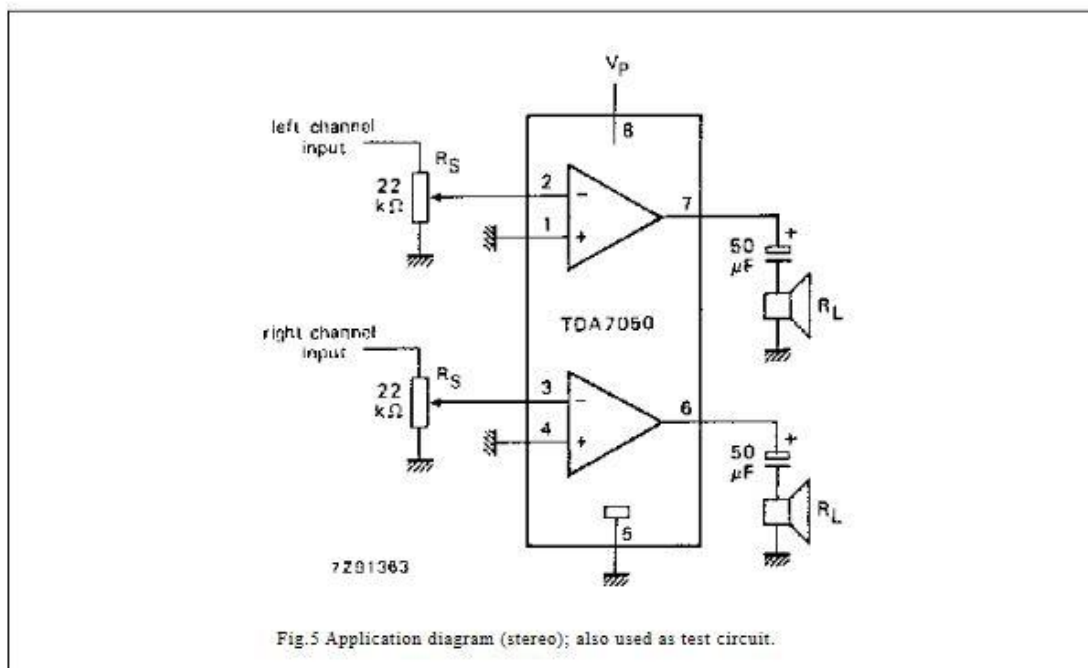

Fig.5 Application diagram (stereo); also used as test circuit.

Low voltage mono/stereo power amplifier

TDA7050

PACKAGE OUTLINE

DIP8: plastic dual in-line package; 8 leads (300 mil)

SOT197-1

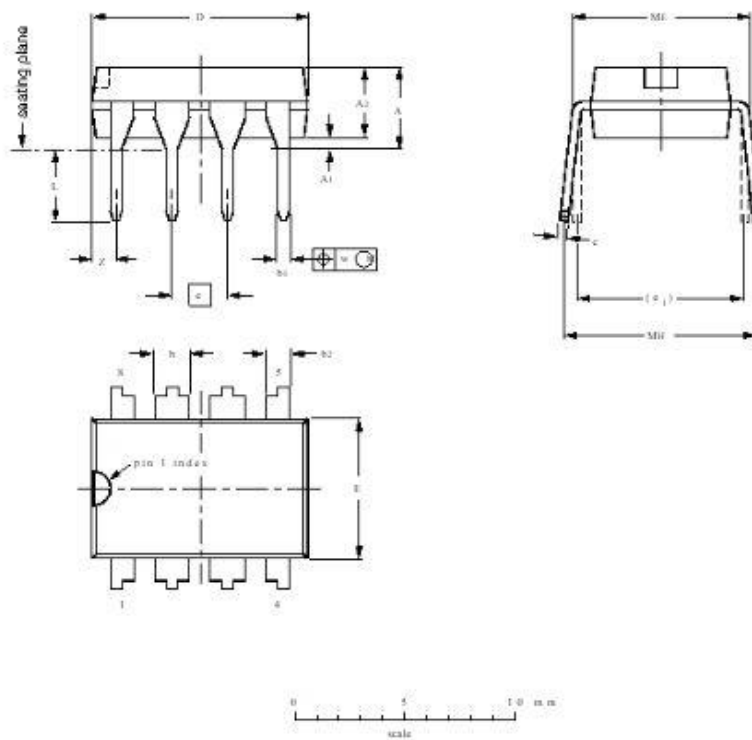

DIMENSIONS (inch dimensions are derived from the original mm dimensions)

UNIT	A max.	A 10 min.	A max.	b	b1	b2	cD	e <sup>(1)</sup>	e <sup>(2)</sup>	e	e 1	L	Me	Mh	v	z <sup>(3)</sup> max.
mm	4.2	0.51	3.2	1.75 1.14	0.51 0.76	1.07 0.59	0.26 0.27	9.3 9.2	6.48 6.20	2.54	7.62	3.80 3.95	8.25 7.60	10.0 8.7	0.254	1.15
inches	0.17	0.020	0.13	0.068 0.045	0.021 0.030	0.042 0.023	0.010 0.009	0.36 0.36	0.26 0.24	0.10	0.30	0.14 0.12	0.32 0.31	0.39 0.33	0.01	0.045

Note

1. Plastic or metal protrusions of 0.25 mm maximum per side are not included.

OUTLINE VERSION	REFERENCES				EUROPEAN PROJECTION	ISSUE DATE
	IEC	JEDEC	EIAJ			
SOT197-1	059G01	MG-001AN				92-11-01 95-02-04

## Low voltage mono/stereo power amplifier

TDA7050

**SOLDERING****Introduction**

There is no soldering method that is ideal for all IC packages. Wave soldering is often preferred when through-hole and surface mounted components are mixed on one printed-circuit board. However, wave soldering is not always suitable for surface mounted ICs, or for printed-circuits with high population densities. In these situations reflow soldering is often used.

This text gives a very brief insight to a complex technology. A more in-depth account of soldering ICs can be found in our "IC Package Databook" (order code 9398 652 90011).

**Soldering by dipping or by wave**

The maximum permissible temperature of the solder is 260 °C; solder at this temperature must not be in contact with the joint for more than 5 seconds. The total contact time of successive solder waves must not exceed 5 seconds.

The device may be mounted up to the seating plane, but the temperature of the plastic body must not exceed the specified maximum storage temperature ( $T_{stg\ max}$ ). If the printed-circuit board has been pre-heated, forced cooling may be necessary immediately after soldering to keep the temperature within the permissible limit.

**Repairing soldered joints**

Apply a low voltage soldering iron (less than 24 V) to the lead(s) of the package, below the seating plane or not more than 2 mm above it. If the temperature of the soldering iron bit is less than 300 °C it may remain in contact for up to 10 seconds. If the bit temperature is between 300 and 400 °C, contact may be up to 5 seconds.

**DEFINITIONS**

<b>Data sheet status</b>	
Objective specification	This data sheet contains target or goal specifications for product development.
Preliminary specification	This data sheet contains preliminary data; supplementary data may be published later.
Product specification	This data sheet contains final product specifications.
<b>Limiting values</b>	
Limiting values given are in accordance with the Absolute Maximum Rating System (IEC 134). Stress above one or more of the limiting values may cause permanent damage to the device. These are stress ratings only and operation of the device at these or at any other conditions above those given in the Characteristics sections of the specification is not implied. Exposure to limiting values for extended periods may affect device reliability.	
<b>Application information</b>	
Where application information is given, it is advisory and does not form part of the specification.	

**LIFE SUPPORT APPLICATIONS**

These products are not designed for use in life support appliances, devices, or systems where malfunction of these products can reasonably be expected to result in personal injury. Philips customers using or selling these products for use in such applications do so at their own risk and agree to fully indemnify Philips for any damages resulting from such improper use or sale.