

## DARLINGTON PLASTIC POWER TRANSISTORS

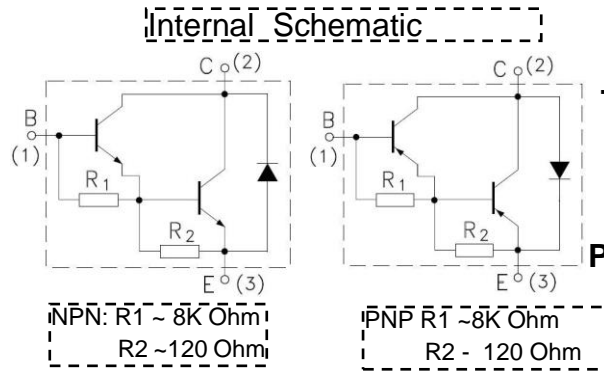
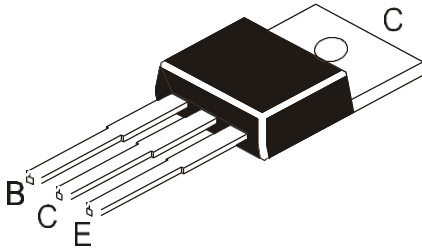

TIP120	TIP125
TIP121	TIP126
TIP122	TIP127
NPN	PNP
TO-220 Plastic Package	

**High Power Switching, Hammer Drive, Pulse Motor Drive and Inductive Load Drive Applications**

### ABSOLUTE MAXIMUM RATINGS

DESCRIPTION		TIP120/125	TIP121/126	TIP122/127	UNIT
Collector Emitter Voltage	$V_{CEO}$	60	80	100	V
Collector Base Voltage	$V_{CBO}$	60	80	100	V
Emitter Base Voltage	$V_{EBO}$		5		V
Collector Current Continuous	$I_C$		5		A
Collector Current Peak	$I_{CM}$		8		A
Base Current	$I_B$		120		mA
Power Dissipation upto $T_c=25^\circ\text{C}$ Derate above $25^\circ\text{C}$	$P_D$		65		W
Power Dissipation upto $T_a=25^\circ\text{C}$ Derate above $25^\circ\text{C}$	$P_D$		0.52		W/ $^\circ\text{C}$
Power Dissipation upto $T_a=25^\circ\text{C}$ Derate above $25^\circ\text{C}$	$P_D$		2		W
Unclamped Inductive Load Energy	*E		16		mW/ $^\circ\text{C}$
Operating And Storage Junction Temperature	$T_j, T_{stg}$		50		mJ
			- 65 to +150		$^\circ\text{C}$

\*  $I_C=1\text{A}$ ,  $L=100\text{mH}$ ,  $P.R.F.=10\text{Hz}$ ,  $V_{CC}=20\text{V}$ ,  $R_{BE}=100\text{W}$

### THERMAL RESISTANCE

Junction to Case	$R_{th(j-c)}$	1.92	$^\circ\text{C/W}$
Junction to Ambient in free air	$R_{th(j-a)}$	62.5	$^\circ\text{C/W}$

### ELECTRICAL CHARACTERISTICS ( $T_c=25^\circ\text{C}$ unless specified otherwise)

DESCRIPTION	SYMBOL	TEST CONDITION	TIP120/125		TIP121/126		TIP122/127		UNIT
			MIN	MAX	MIN	MAX	MIN	MAX	
Collector Emitter (sus) Voltage	* $V_{CEO(sus)}$	$I_C=100\text{mA}$ , $I_B=0$	60		80		100		V
Collector Cut Off Current	$I_{CEO}$	$V_{CE}=50\text{V}$ , $I_B=0$						0.5	mA
		$V_{CE}=40\text{V}$ , $I_B=0$					0.5		mA
		$V_{CE}=30\text{V}$ , $I_B=0$		0.5					mA
Collector Cut Off Current	$I_{CBO}$	$V_{CB}=100\text{V}$ , $I_E=0$						0.2	mA
		$V_{CB}=80\text{V}$ , $I_E=0$					0.2		mA
		$V_{CB}=60\text{V}$ , $I_E=0$		0.2					mA
Emitter Cut Off Current	$I_{EBO}$	$V_{EB}=5\text{V}$ , $I_C=0$		2.0		2.0		2.0	mA
DC Current Gain	* $h_{FE}$	$I_C=0.5\text{A}$ , $V_{CE}=3\text{V}$	1000		1000		1000		
		$I_C=3\text{A}$ , $V_{CE}=3\text{V}$	1000		1000		1000		
Collector Emitter Saturation Voltage	* $V_{CE(sat)}$	$I_C=3\text{A}$ , $I_B=12\text{mA}$		2.0		2.0		2.0	V
		$I_C=5\text{A}$ , $I_B=20\text{mA}$		4.0		4.0		4.0	V
Base Emitter On Voltage	* $V_{BE(on)}$	$I_C=3\text{A}$ , $V_{CE}=3\text{V}$		2.5		2.5		2.5	V

\*Pulse Test : Pulse width  $\leq 300\text{ms}$ , Duty Cycle  $\leq 2\%$

# DARLINGTON PLASTIC POWER TRANSISTORS

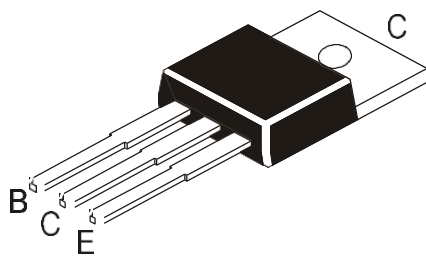

TIP120	TIP125
TIP121	TIP126
TIP122	TIP127
NPN	PNP

**TO-220  
Plastic Package**

## ELECTRICAL CHARACTERISTICS ( $T_C=25^{\circ}\text{C}$ unless specified otherwise)

### DYNAMIC CHARACTERISTIC

DESCRIPTION	SYMBOL	TEST CONDITION	MIN	TYP	MAX	UNIT
Small Signal Current Gain	$h_{fe}$	$I_C=3\text{A}, V_{CE}=4\text{V}, f=1\text{MHz}$	4			
Output Capacitance	$C_{ob}$	$V_{CB}=10\text{V}, I_E=0, f=0.1\text{MHz}$ TIP125,126,127 TIP120,121,122			300 200	$\mu\text{F}$ $\mu\text{F}$

### SWITCHING CHARACTERISTICS

DESCRIPTION	SYMBOL	TEST CONDITION	MIN	TYP	MAX	UNIT
Turn on time	$t_{on}$	$I_C=3\text{A}, R_L=10\Omega$ $I_{B1}=I_{B2}=12\text{mA}$		0.4		$\mu\text{s}$
Turn off time	$t_{off}$	$V_{EB(off)}=5\text{V}$		1.2		$\mu\text{s}$

TIP120	TIP125
TIP121	TIP126
TIP122	TIP127
NPN	PNP

## TO-220 Plastic Package

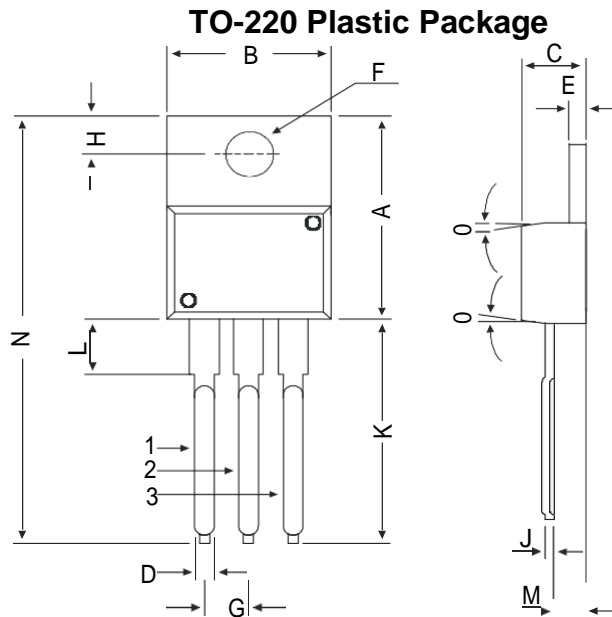

DIM	MIN	MAX
A	14.42	16.51
B	9.63	10.67
C	3.56	4.83
D	—	0.90
E	1.15	1.40
F	3.75	3.88
G	2.29	2.79
H	2.54	3.43
J	—	0.56
K	12.70	14.73
L	2.80	4.07
M	2.03	2.92
N	—	31.24
O	7 DEG	

All dimensions in mm.

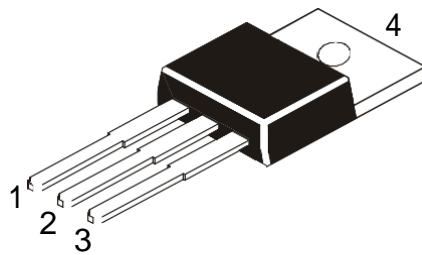

### Pin Configuration

1. Base
2. Collector
3. Emitter
4. Collector

### TO-220 Tube Packing

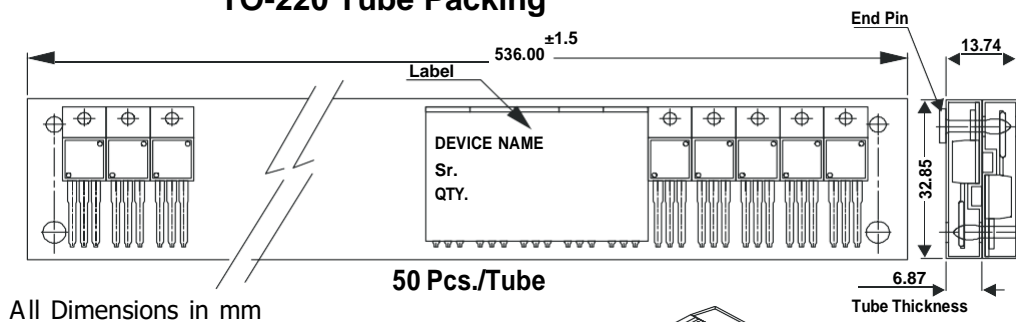

50 Pcs./Tube

AMMO PACK SIZE

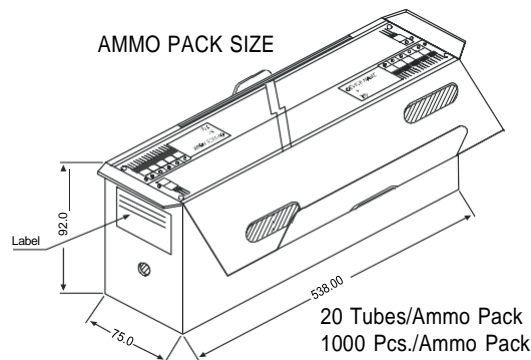

### Packing Detail

PACKAGE	STANDARD PACK		INNER CARTON BOX		OUTER CARTON BOX		
	Details	Net Weight/Qty	Size	Qty	Size	Qty	GrWt
TO-220 /FP	200 pcs/polybag	396 gm/200 pcs	3" x 7.5" x 7.5"	1.0K	17" x 15" x 13.5"	16.0K	36 kgs
	50 pcs/tube	120 gm/50 pcs	3.5" x 3.7" x 21.5"	1.0K	19" x 19" x 19"	10.0K	29 kgs

**Disclaimer**

The product information and the selection guides facilitate selection of the CDIL's Semiconductor Device(s) best suited for application in your product(s) as per your requirement. It is recommended that you completely review our Data Sheet(s) so as to confirm that the Device(s) meet functionality parameters for your application. The information furnished in the Data Sheet and on the CDIL Web Site/CD are believed to be accurate and reliable. CDIL however, does not assume responsibility for inaccuracies or incomplete information. Furthermore, CDIL does not assume liability whatsoever, arising out of the application or use of any CDIL product; neither does it convey any license under its patent rights nor rights of others. These products are not designed for use in life saving/support appliances or systems. CDIL customers selling these products (either as individual Semiconductor Devices or incorporated in their end products), in any life saving/support appliances or systems or applications do so at their own risk and CDIL will not be responsible for any damages resulting from such sale(s).

CDIL strives for continuous improvement and reserves the right to change the specifications of its products without prior notice.



CDIL is a registered Trademark of  
Continental Device India Pvt. Limited