



# TO-220-3L Plastic-Encapsulate Transistors

## TIP42C TRANSISTOR (PNP)

### FEATURES

- Medium Power Linear Switching Applications
- Complement to TIP41/41A/41B/41C

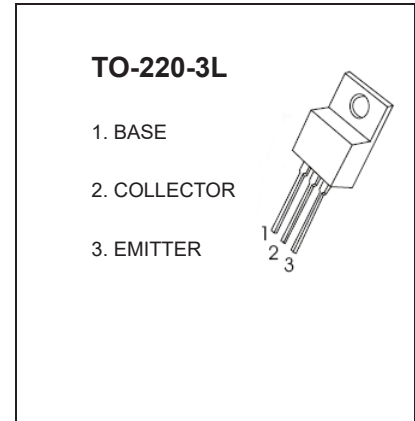

### MARKING

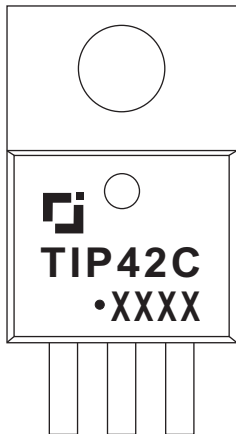

TIP42C=Device code  
 Solid dot=Green moldinn compound device,  
 if none,the normal device  
 XXXX=Code

### Equivalent Circuit

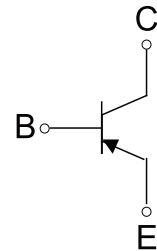

### MAXIMUM RATINGS (Ta=25°C unless otherwise noted)

Symbol	Parameter	Value	Unit
V <sub>CB0</sub>	Collector-Base Voltage	-100	V
V <sub>CEO</sub>	Collector-Emitter Voltage	-100	V
V <sub>EBO</sub>	Emitter-Base Voltage	-5	V
I <sub>c</sub>	Collector Current -Continuous	-6	A
P <sub>C</sub>	Collector Power Dissipation	2	W
T <sub>J</sub> , T <sub>stg</sub>	Operation Junction and Storage Temperature Range	-55to+150	°C

**ELECTRICAL CHARACTERISTICS (T<sub>a</sub>=25°C unless otherwise specified)**

Parameter	Symbol	Test conditions	Min	Max	Unit
Collector-base breakdown voltage	V <sub>(BR)CBO</sub>	I <sub>C</sub> = -1mA, I <sub>E</sub> =0	-100		V
Collector-emitter breakdown voltage	V <sub>(BR)CEO</sub> *	I <sub>C</sub> = -30mA, I <sub>B</sub> =0	-100		V
Emitter-base breakdown voltage	V <sub>(BR)EBO</sub>	I <sub>E</sub> = -1mA, I <sub>C</sub> =0	-5		V
Collector cut-off current	I <sub>CBO</sub>	V <sub>CB</sub> =-100V, I <sub>E</sub> =0		-0.4	mA
Collector cut-off current	I <sub>CEO</sub>	V <sub>CE</sub> = -60V, I <sub>B</sub> = 0		-0.7	mA
Emitter cut-off current	I <sub>EBO</sub>	V <sub>EB</sub> =-5V, I <sub>C</sub> =0		-1	mA
DC current gain	h <sub>FE(1)</sub>	V <sub>CE</sub> =-4V, I <sub>C</sub> =-0.3A	30		
	h <sub>FE(2)</sub>	V <sub>CE</sub> =-4 V, I <sub>C</sub> = -3A	15	75	
Collector-emitter saturation voltage	V <sub>CE(sat)</sub>	I <sub>C</sub> =-6A, I <sub>B</sub> =-0.6A		-1.5	V
Base-emitter voltage	V <sub>BE</sub>	V <sub>CE</sub> =-4V, I <sub>C</sub> =-6A		-2	V
Transition frequency	f <sub>T</sub>	V <sub>CE</sub> =-10V, I <sub>C</sub> =-0.5	3		MHz

\* Pulse test

# Typical Characteristics

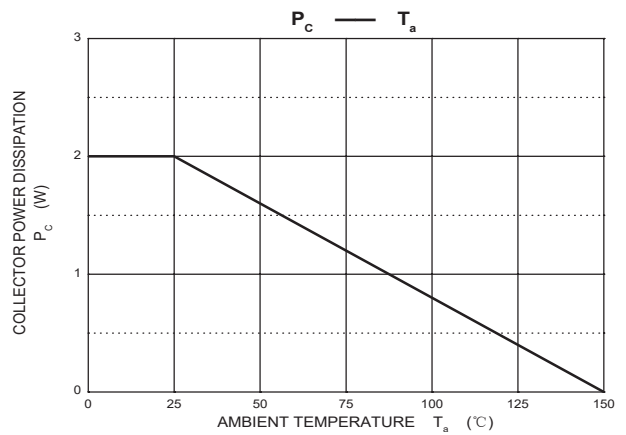
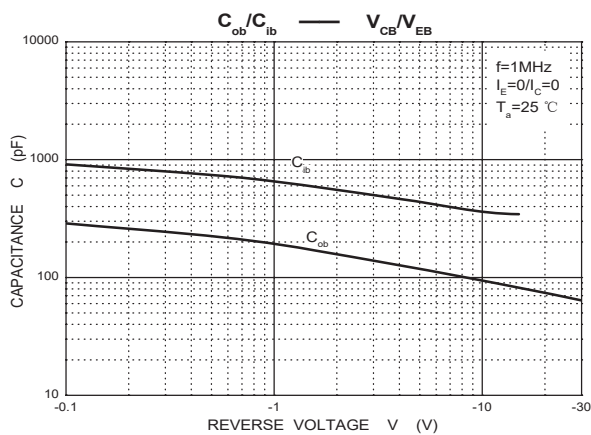
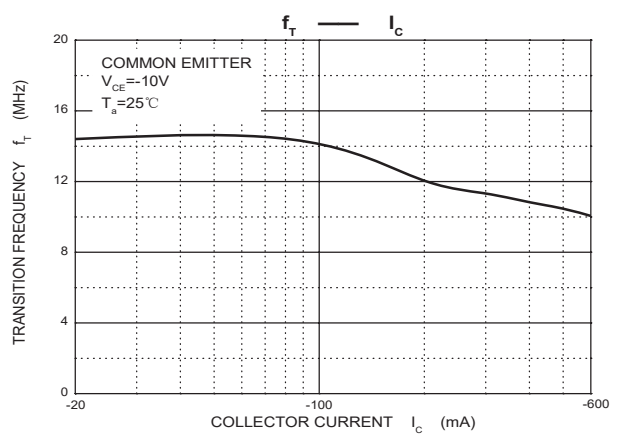
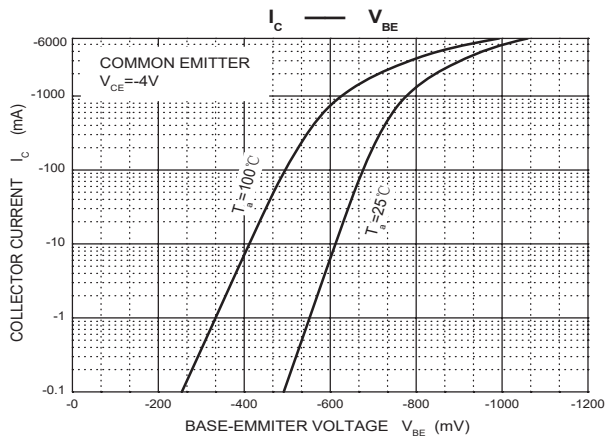
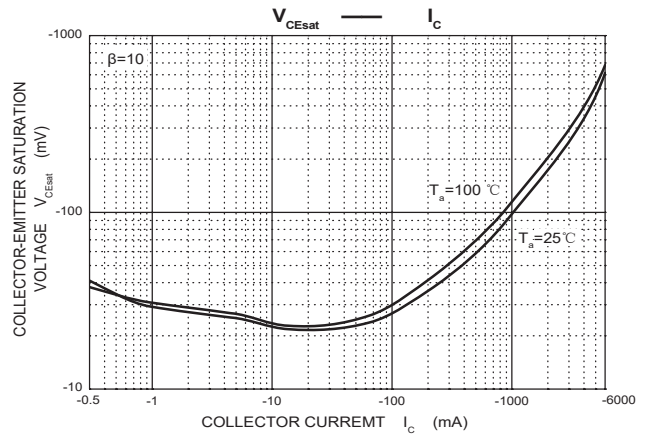
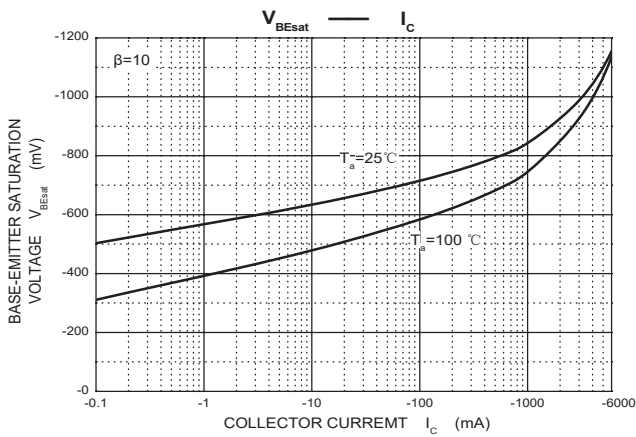
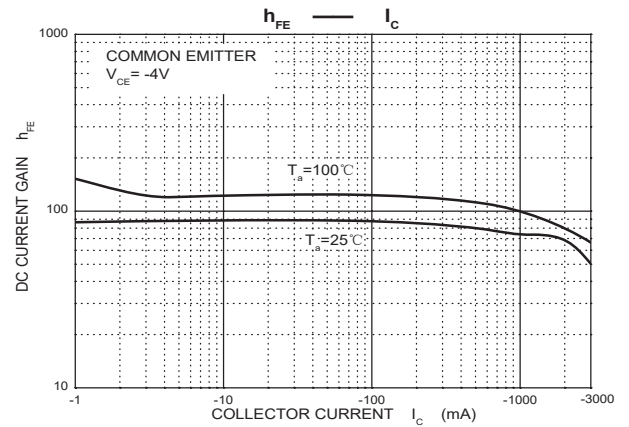
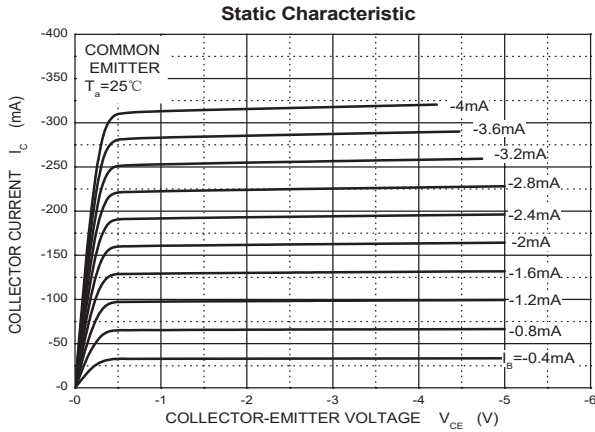

# TO-220-3L Package Outline Dimensions

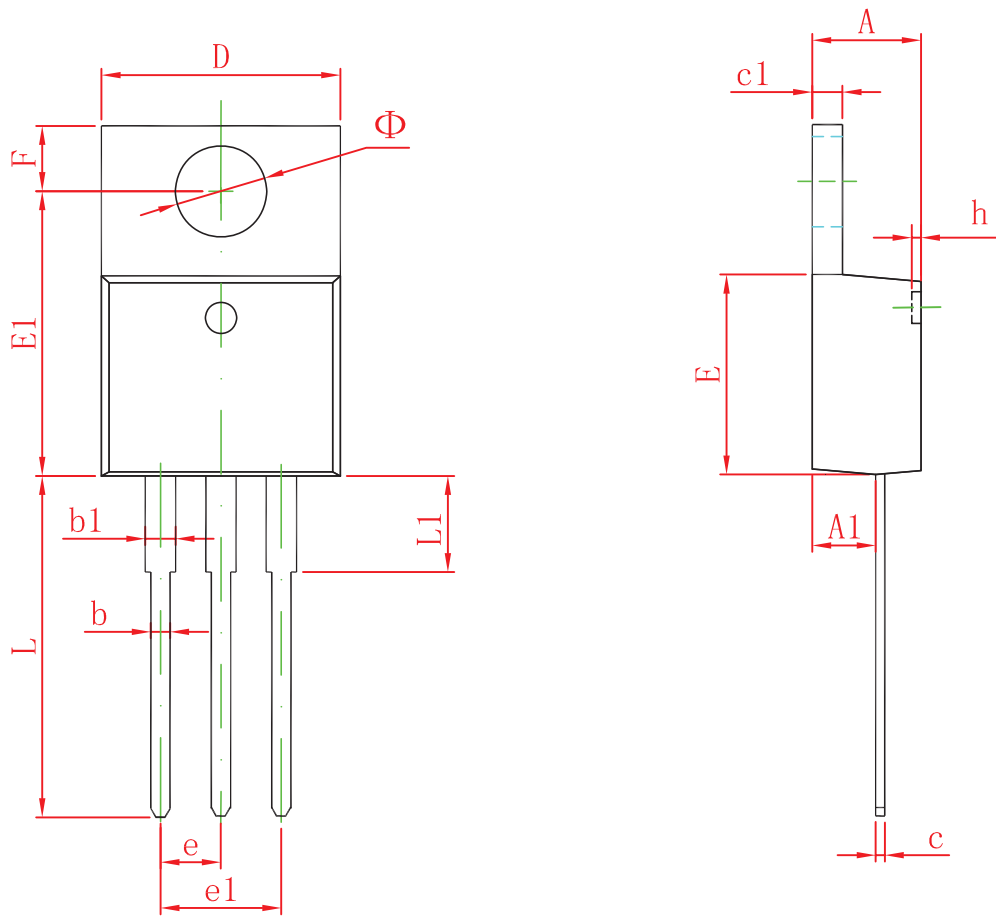

Symbol	Dimensions In Millimeters		Dimensions In Inches	
	Min	Max	Min	Max
A	4.470	4.670	0.176	0.184
A1	2.520	2.820	0.099	0.111
b	0.710	0.910	0.028	0.036
b1	1.170	1.370	0.046	0.054
c	0.310	0.530	0.012	0.021
c1	1.170	1.370	0.046	0.054
D	10.010	10.310	0.394	0.406
E	8.500	8.900	0.335	0.350
E1	12.060	12.460	0.475	0.491
e	2.540 TYP		0.100 TYP	
e1	4.980	5.180	0.196	0.204
F	2.590	2.890	0.102	0.114
h	0.000	0.300	0.000	0.012
L	13.400	13.800	0.528	0.543
L1	3.560	3.960	0.140	0.156
$\Phi$	3.735	3.935	0.147	0.155